

SYM	ZONE	DESCRIPTION	DATE	CH. NO.	SHAFTS	CHECKER	ENGR.
		UNLESS OTHERWISE SPECIFIED:					
DIMENSIONS ARE IN INCHES			SCALE		FULL		
TOLERANCES ON FRACTIONS & 1/64			DECIMALS & .005		ANGLES & 1/2°		
MAXIMUM ALLOWABLE TOLERANCES HAVE BEEN DETERMINED AND ANY DEVIATIONS WILL BE CAUSE FOR REJECTION. REMOVE ALL BURRS & SHARP EDGES							

- UNLESS OTHERWISE SPECIFIED:
1. USE MATERIAL THICKNESS FOR MAXIMUM RADIIUS ON ALL BENDS.
 2. ALL ANGULAR BENDS 90°.
 3. REMOVE ALL BURRS AND SHARP EDGES.
 4. MOUNT INSERTS AFTER FINISHING.

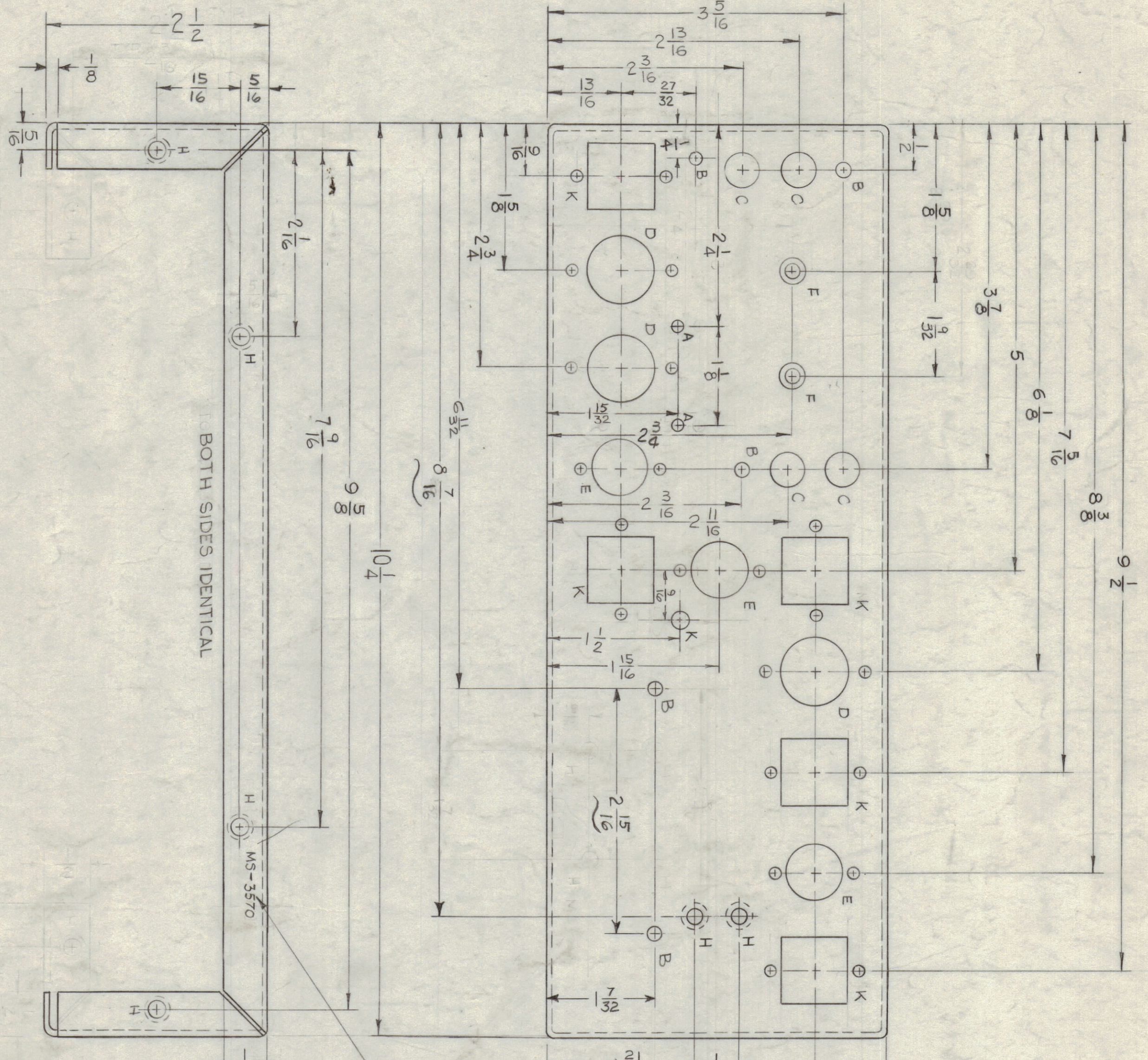

METAL STAMP TMC PART NO. 1/8 HIGH GOTHIC.

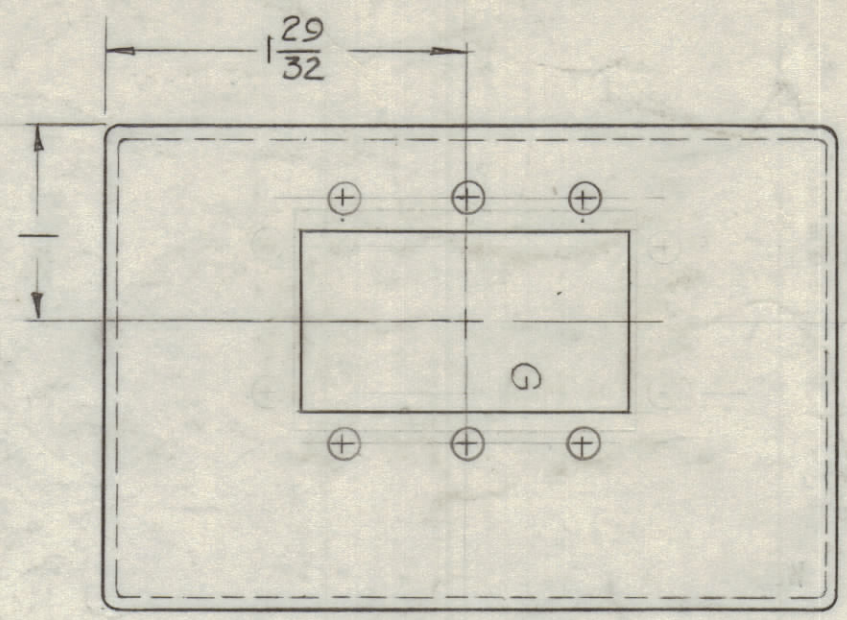
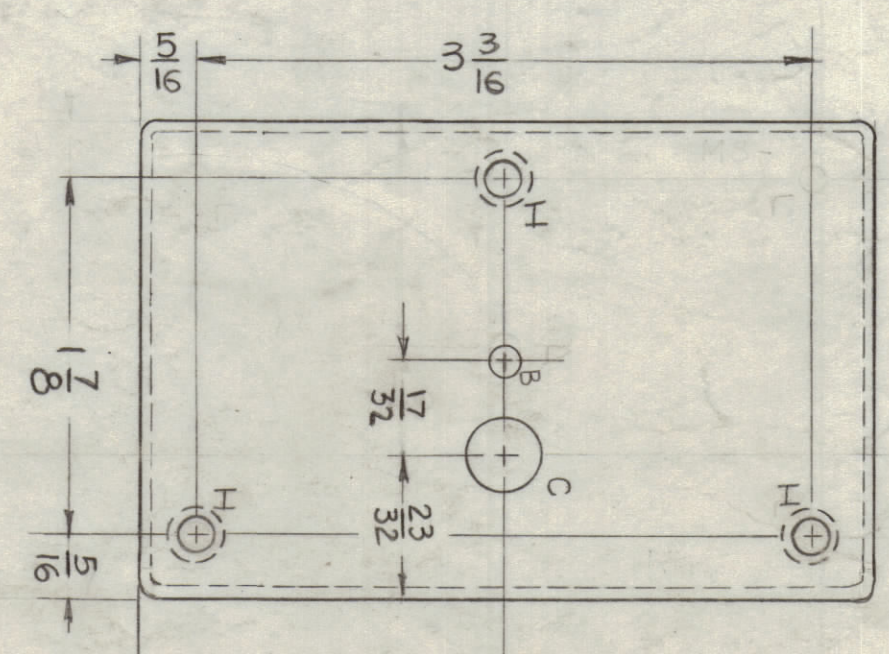

HOLE	DESCRIPTION	REQD.
A	1/8 DIA.	2
B	5/32 DIA.	6
C	3/8 DIA.	5
D	SEE DETAIL "D"	3
E	SEE DETAIL "E"	3
F	SEE DETAIL "F"	2
G	SEE DETAIL "G"	1
H	.194 - .191 DIA	13
K	3/16 DIA.	5

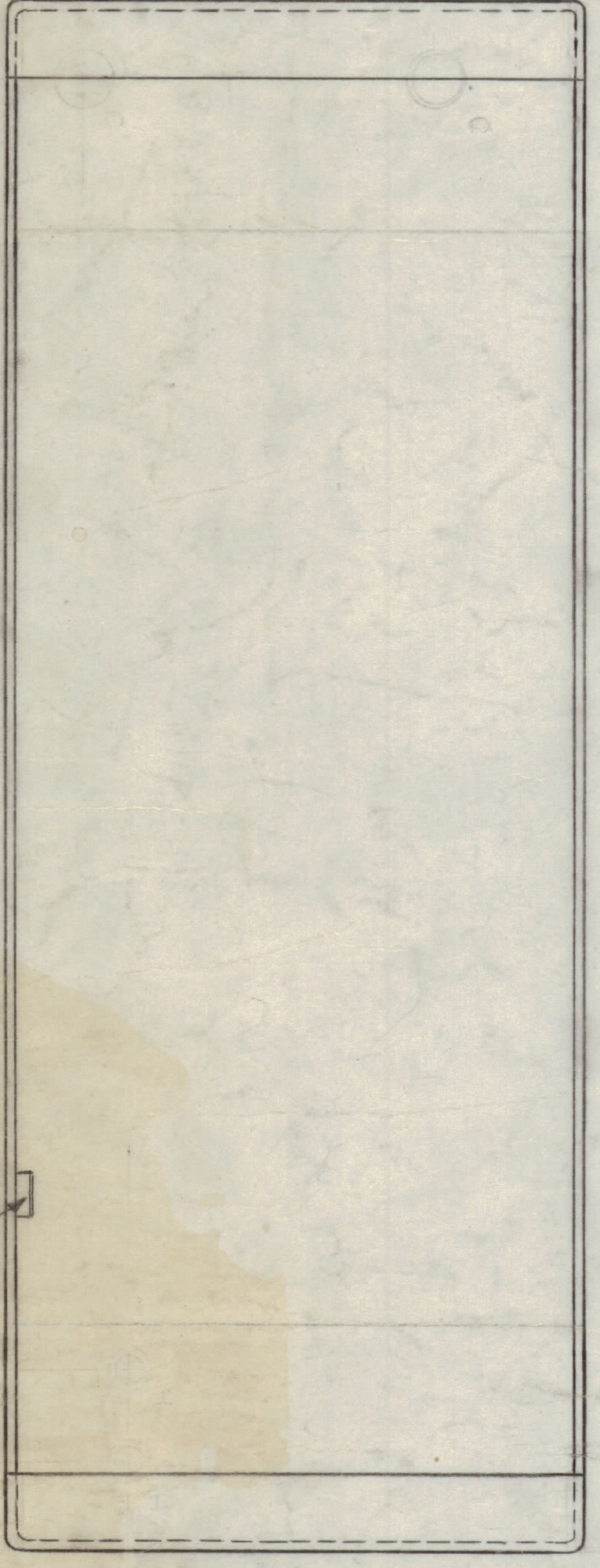

REF: LD-1403

REQ. QTY	13	1
TRM	NT-129-632-4	
PART NO.	ALTOUDEN	
DESCRIPTION	NUT, ROUND, SWAGE TYPE	
STOCK SIZE	.064	
MATERIAL	ALUMINUM	
TYPE & TEMPER	5052-H32	
HEAT TREAT SPEC.	S404-YELLOW IRIDITE	
FINISH & SPEC. NO.		

DETAIL "K"

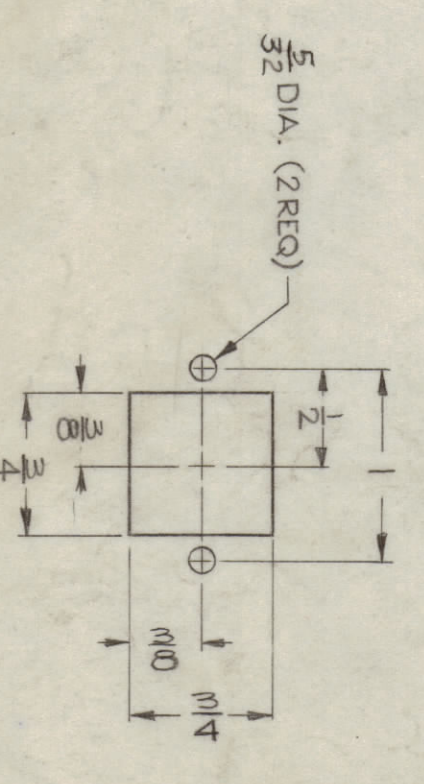

DETAIL "G"

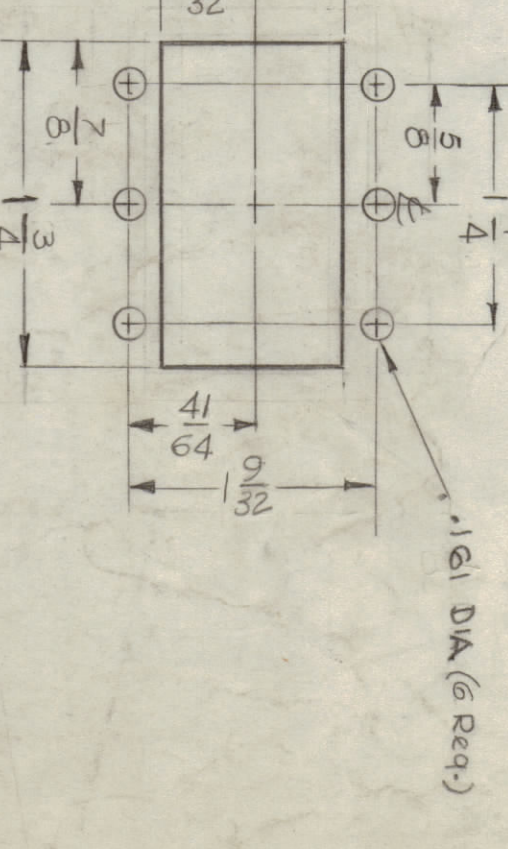

DETAIL "F"



DETAIL "E"

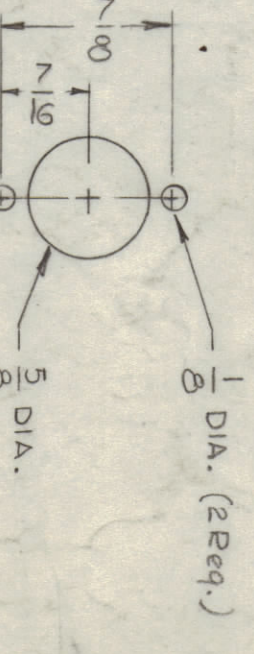

DETAIL "D"

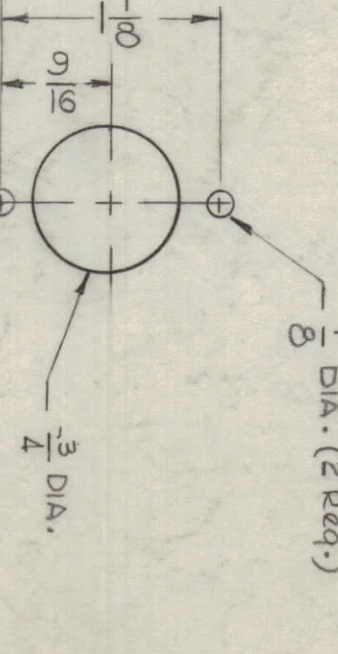

MS-3570