

REQ. PER UNIT	USED ON			MS-3548	0
	MODEL	ASS'Y. NO.	DATE		
4	GPT-200K	AR-137	11-13-63		
4	GPT-200K	AR-138	11-13-63		

HOLE	DESCRIPTION	REQ.
A	.191-.194 DIA.	1
B	11/64 X 11/32 SLOT	2

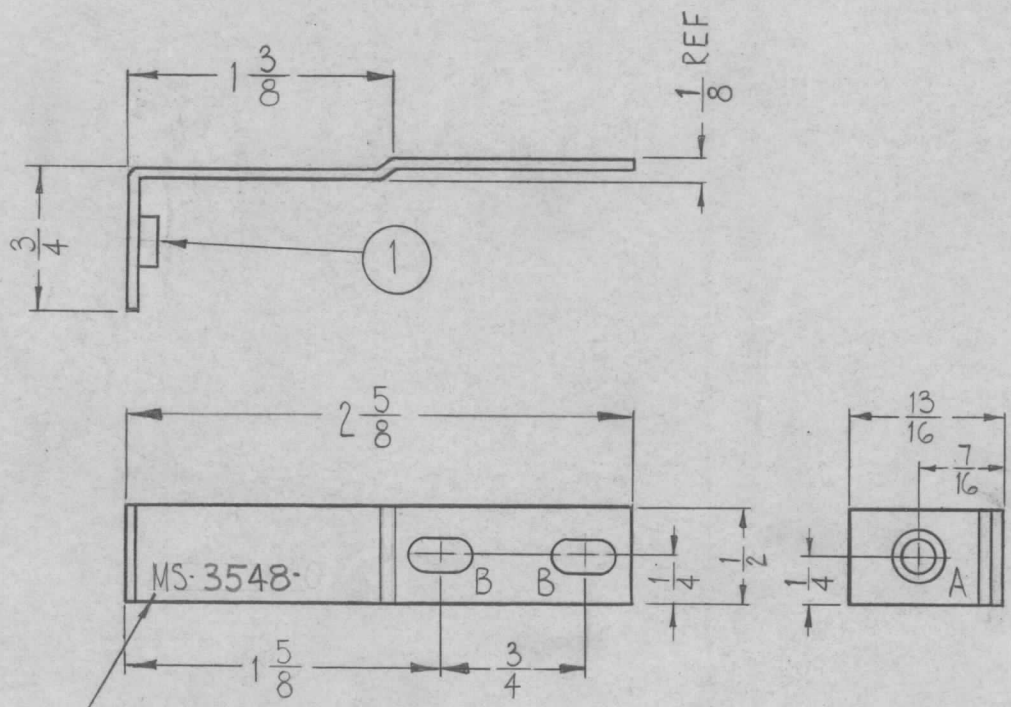

METAL STAMP TMC PART NO.
W/LATEST REV. LETTER
1/8 HIGH GOTHIC.

UNLESS OTHERWISE SPECIFIED:

1. USE MATERIAL THICKNESS FOR MAXIMUM RADIUS ON ALL BENDS.
2. ALL ANGULAR BENDS 90°.
3. REMOVE ALL BURRS AND SHARP EDGES.
4. MOUNT INSERTS BEFORE FINISHING.

FINISH NOTES:

1. S404 - IRIDITE 14-2 AL-COAT.
2. S114 - ZINC CHROMATE PRIMER
3. S520 - BLUE-GRAY TEXTURED VINYL PAINT (ALL OVER).

1	1	NT-129-632-4	NUT, ROUND, SWAGE TYPE			A
REQ.	ITEM	PART NO.	F. BUDETTI DESCRIPTION			SYMBOL
		.062 THICK	THE TECHNICAL MATERIEL CORP.			
		STOCK SIZE	MAMARONECK, NEW YORK			
0	ORIGINAL RELEASE FOR PROD.	4-24-64	SRG	BRACKET, COVER MTG.		
SYM	DESCRIPTION	DATE	CH. NO.	DRAFTS	CHECKER	ENG. APP.
UNLESS OTHERWISE SPECIFIED DIMENSIONS ARE IN INCHES AND INCLUDE CHEMICALLY APPLIED OR PLATED FINISHES		SCALE	1:1			
DECIMALS .X ± .05 .XX ± .01 .XXX ± .005	TOLERANCES	FRACTIONS ± 1/64 ANGLES ± 0° 30'	CODE	A		
				5052-H32	W.A. FRANCO	aa
				TYPE & TEMPER	HEAT TREAT. SPEC.	DRAWN
				SEE NOTES		checked LB
				FINISH & SPEC. NO.	ELEC. DES. APP.	MECH. DES. APP.
						MS-3548 0