

IF IT IS FOUND DESIRABLE TO CHANGE ANY TOLERANCE OR OTHER DETAIL SPECIFIED ON THIS DRAWING NOTIFY THE PURCHASER PROMPTLY.  
 MAXIMUM ALLOWABLE TOLERANCES HAVE BEEN DETERMINED AND DEVIATIONS WILL BE CAUSE FOR REJECTION.  
 REMOVE ALL BURRS AND SHARP EDGES

METAL STAMP TMC PART NO.  
 1/8 HIGH GOTHIC, ON REAR  
 MS-3491

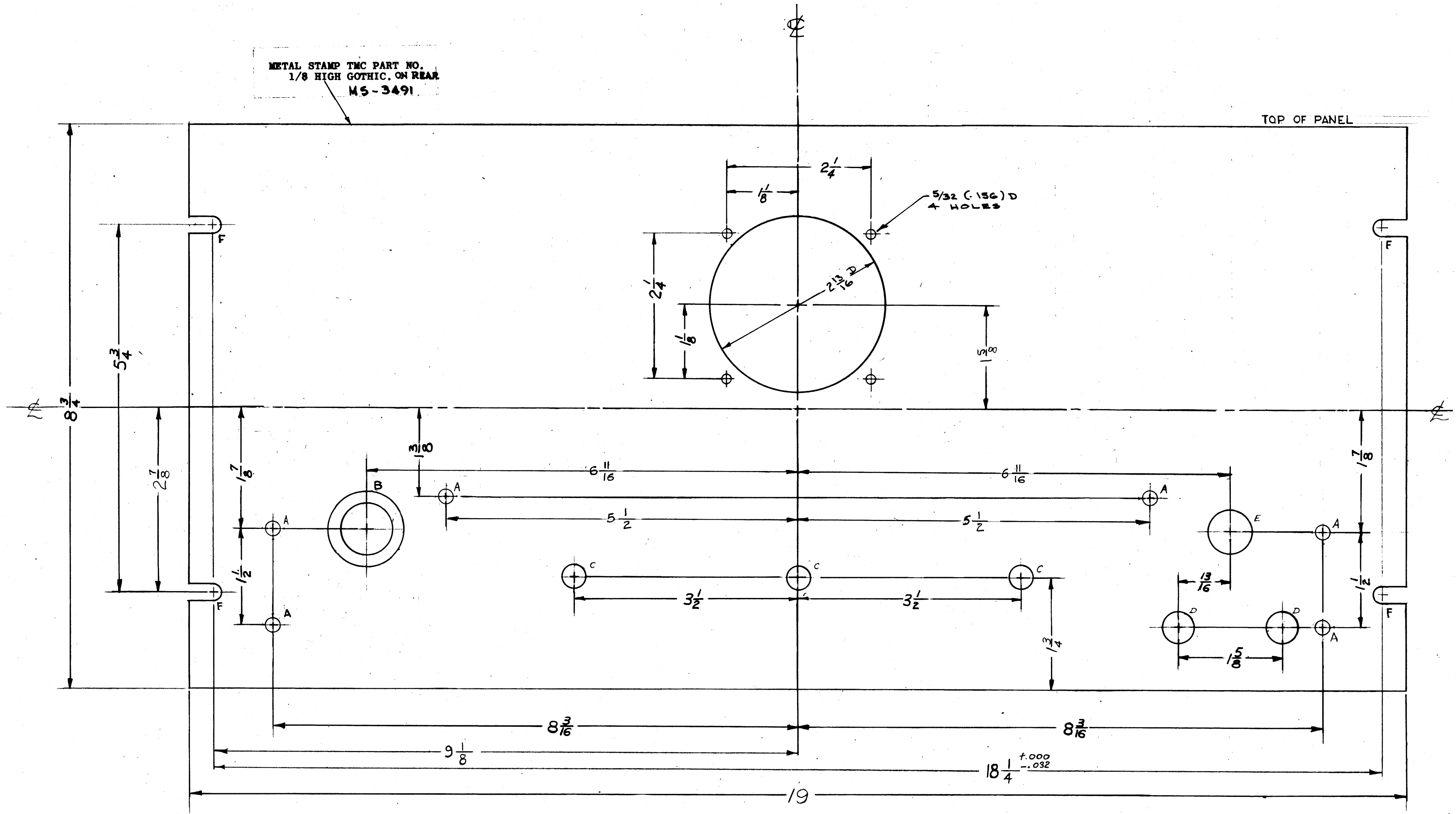

FRONT OF PANEL SHOWN

- MACHINING:**
1. MILL ALL EDGES.
  2. HOLES MUST BE DRILLED, UNLESS OTHERWISE SPECIFIED.
  3. LATERAL BOW OF PANEL MUST BE KEPT TO .031 TOLERANCE.
  4. PANEL MUST BE FREE OF ALL MACHINING MARKS, GOUGES AND SCRATCHES. IF NECESSARY, SAND FRONT OF PANEL WITH NO. 120 GRIT SANDPAPER.

- FINISH NOTES:**
1. S404 - IRIDITE 14-2 AL-COAT.
  2. S114 - ZINC CHROMATE PRIMER ) FRONT AND
  3. S115 - SMOOTH GRAY ENAMEL ) EDGES ONLY

LEGEND		
HOLE	DESCRIPTION	REQ.
A	7/32 DIA.	6
B	SEE DETAIL "B"	1
C	25/64 DIA.	3
D	31/64 DIA.	2
E	45/64 DIA.	1
F	SEE DETAIL "F"	4

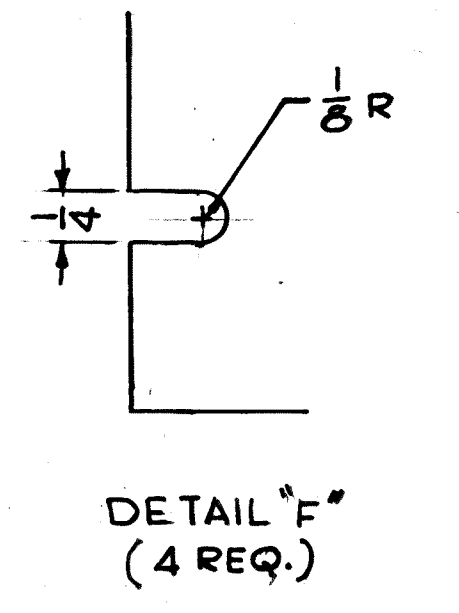
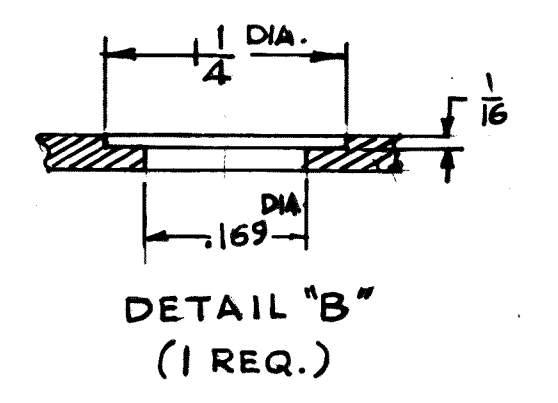

MS-3491

THE TECHNICAL MATERIEL CORPORATION  
 14 MAMARONECK, NEW YORK

REF: LD-1356

REQ. ITEM	PART NO.	DESCRIPTION	SYMBOL
	3/16 THK.	THE TECHNICAL MATERIEL CORP. MAMARONECK, NEW YORK	
MATERIAL		ALUMINUM	FRONT PANEL MACHINING
WEIGHT PER PC.		245-73	RTC-2
TYPE & TEMPER		G.D.L.	
HEAT TREAT. SPEC.		SEE NOTE	
FINISH & SPEC. NO.		MS-3491	

ISSUE	ITEM	CHANGED FROM	DATE	CN. NO.	DRAFTS	CHECKER	ENG. APP.

ORIGINAL RELEASE FOR PRODUCTION

SCALE: 1:1

DRILL, PUNCH, COMMERCIAL STOCK SIZES AND MANUFACTURERS TOLERANCES ARE NOT INCLUDED.

REQ. PER UNIT	MODEL	PROJECT NO.	ASSY. NO.	DATE
	RTC-2			9-14-63

IF IT IS FOUND DESIRABLE TO CHANGE ANY TOLERANCE OR OTHER DETAIL SPECIFIED ON THIS DRAWING NOTIFY THE PURCHASER PROMPTLY.  
 MAXIMUM ALLOWABLE TOLERANCES HAVE BEEN DETERMINED AND DEVIATIONS WILL BE CAUSE FOR REJECTION.  
 REMOVE ALL BURRS AND SHARP EDGES

METAL STAMP TMC PART NO. 1/8 HIGH GOTHIC, ON REAR MS-3491

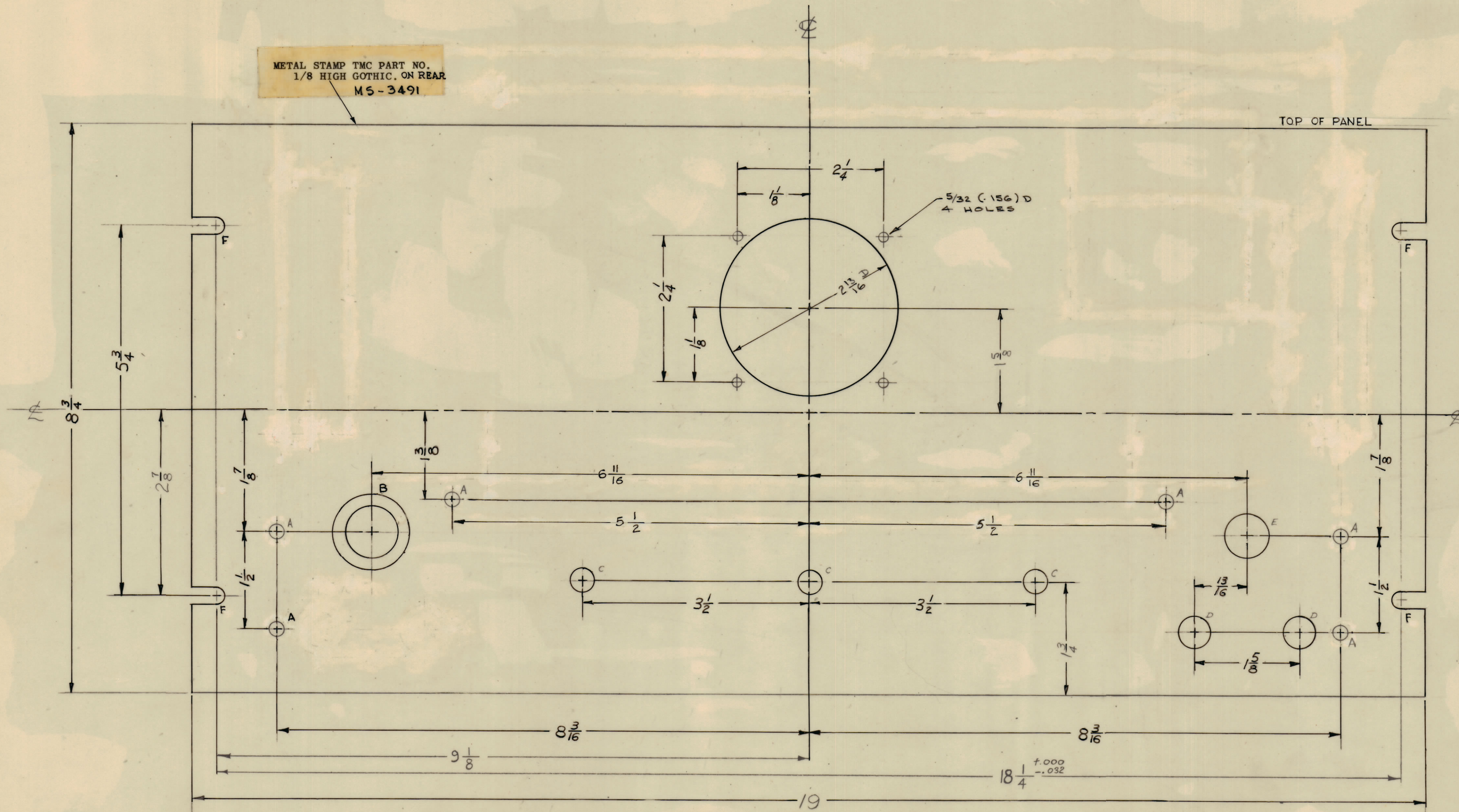

FRONT OF PANEL SHOWN

MACHINING:

1. MILL ALL EDGES.
2. HOLES MUST BE DRILLED, UNLESS OTHERWISE SPECIFIED.
3. LATERAL BOW OF PANEL MUST BE KEPT TO .031 TOLERANCE.
4. PANEL MUST BE FREE OF ALL MACHINING MARKS, GOUGES AND SCRATCHES. IF NECESSARY, SAND FRONT OF PANEL WITH NO. 120 GRIT SANDPAPER.

FINISH NOTES:

1. S404 - IRIDITE 14-2 AL-COAT.
2. S114 - ZINC CHROMATE PRIMER) FRONT AND
3. S115 - SMOOTH GRAY ENAMEL ) EDGES ONLY

LEGEND		
HOLE	DESCRIPTION	REQ.
A	7/32 DIA.	6
B	SEE DETAIL "B"	1
C	25/64 DIA.	3
D	31/64 DIA.	2
E	45/64 DIA.	1
F	SEE DETAIL "F"	4

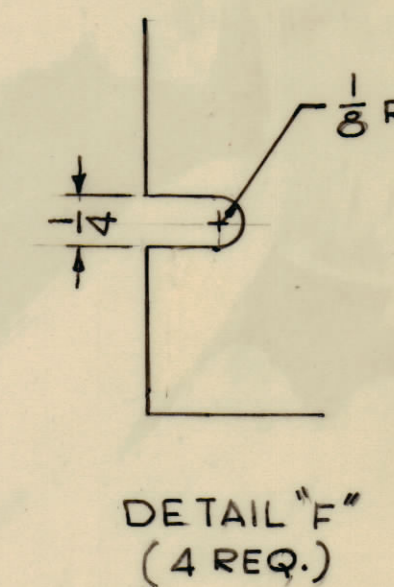
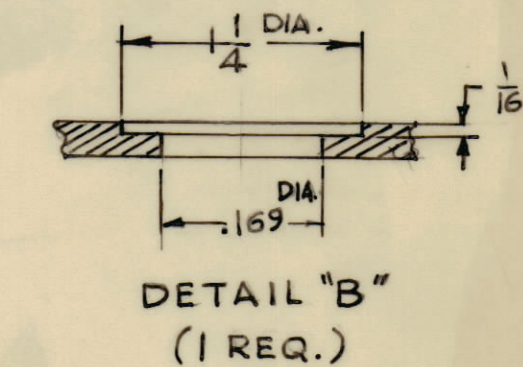

MS-3491

RECEIVING THIS DRAWING... THE TECHNICAL MATERIEL CORPORATION claims... MAMARONECK, NEW YORK

REF: LD-1356

REQ. ITEM	PART NO.	DESCRIPTION	SYMBOL
3/16 THK.		THE TECHNICAL MATERIEL CORP. MAMARONECK, NEW YORK	
ALUMINUM		FRONT PANEL MACHINING	
245-73		RTC-2	
		G.D.L.	
		DRAWN	
		ELEC. DES.	
		MECH. DES.	
		CHECKED	
		FINAL APPROVAL	

REQ. PER UNIT	MODEL	PROJECT NO.	ASSY. NO.	DATE
1	RTC-2			9-14-63

ISSUE ITEM	CHANGED FROM	DATE	CN. NO.	DRAFTS	CHECKER	ENG. APP.
ORIGINAL RELEASE FOR PRODUCTION						