

REQ. PER UNIT	USED ON			MS-3342 A
	MODEL	ASS'Y. NO.	DATE	
60	GPT-200K(AS-124)	AX-442	9-2-63	

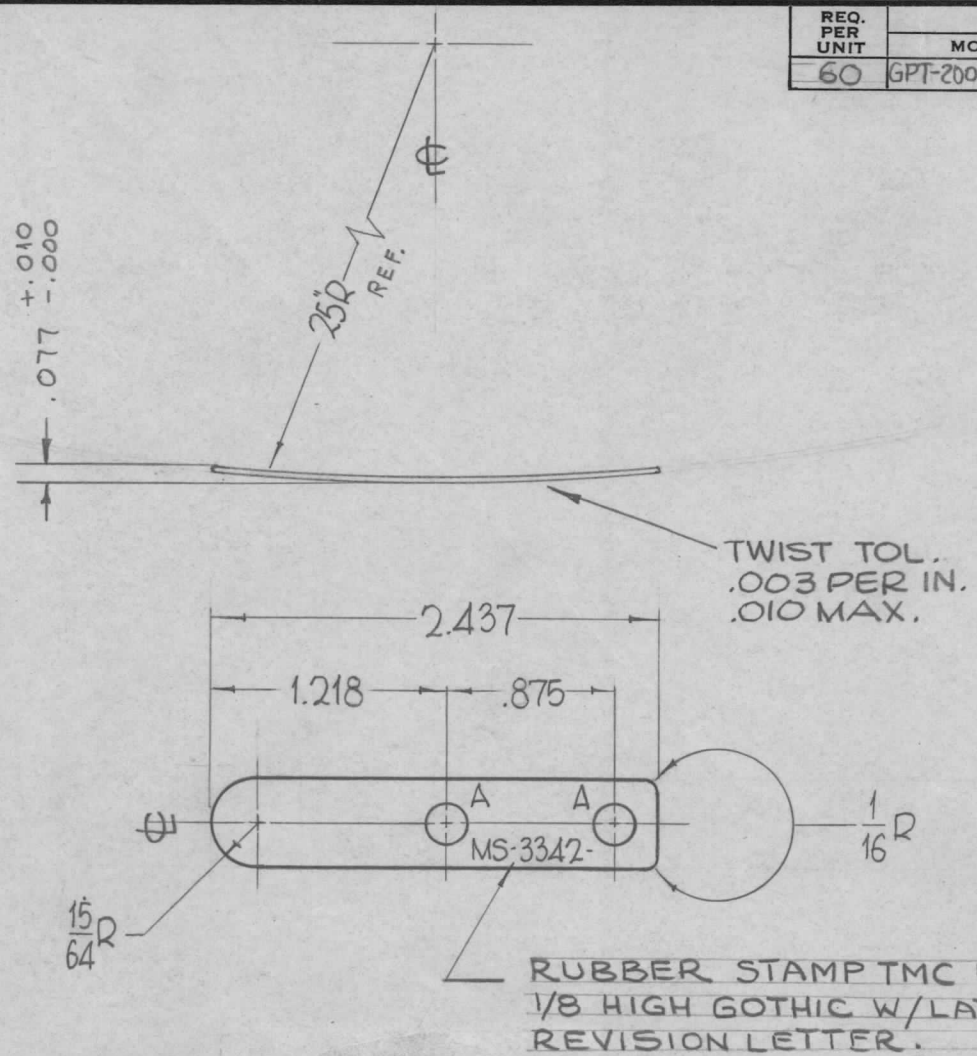

HOLES REQ.  
A-.218DIA. 2

NOTES:  
1~ SPRING TO BE BENT AFTER DRILLING  
2~ ALL EDGES, BUFFED ROUND.  
3~ HOLD AT 600°F FOR 3 HOURS  
LET AIR COOL  
4~ FINISH-S245 SILVER PLATE BRIGHT  
S423 IRIDITE, 18P SILVER KOTE

SYM	DESCRIPTION	DATE	CH. NO.	DRAFTS	CHECKER	ENG. APP.	REQ. ITEM	PART NO.	DESCRIPTION	SYMBOL	
A	STAMP WAS "METAL"	8-26-64	12201	KB	JCD	Sp			<b>THE TECHNICAL MATERIEL CORP.</b> MAMARONECK, NEW YORK <b>SPRING, PRESSURE IT-2</b>		
O	ORIG. RELEASE FOR PROD.	5-16-64		SRG			.040 THICK	STOCK SIZE			
A	TWIST TOL ADDED NOTE 3 ADDED & RE-ARRANGED	5-11-64		SRG			COPPER	MATERIAL			
UNLESS OTHERWISE SPECIFIED DIMENSIONS ARE IN INCHES AND INCLUDE CHEMICALLY APPLIED OR PLATED FINISHES		SCALE		1" = 1"			BERYLIUM		John C. Biele	QA	RAC
DECIMALS .X ± .05 .XX ± .01 .XXX ± .005		FRACTIONS ± 1/64 ANGLES ± 0° 30'		TOLERANCES		TYPE & TEMPER		HEAT TREAT. SPEC.	DRAWN	CHECKED	FINAL APPROVAL
						SEE NOTES			OB	4/4/64	MS-3342 A
						FINISH & SPEC. NO.		ELEC. DES. APP.	MECH. DES. APP.		