

REVISIONS						
ZONE	SYM	DESCRIPTION	DATE	E.M.N. NO.	DRAFT	CHKD APPD
	0	ORIGINAL RELEASE FOR PRODUCTION	3-264		A.M.	

METAL STAMP TMC
PART NO. $\frac{1}{8}$ " HIGH
GOTHIC AS SHOWN

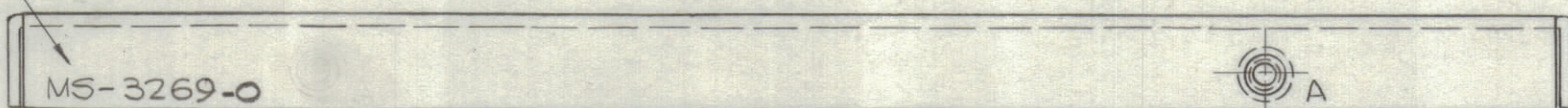

HOLES:
A-.191-194 DIA. — 9REQ.
B~ SEE DETAIL

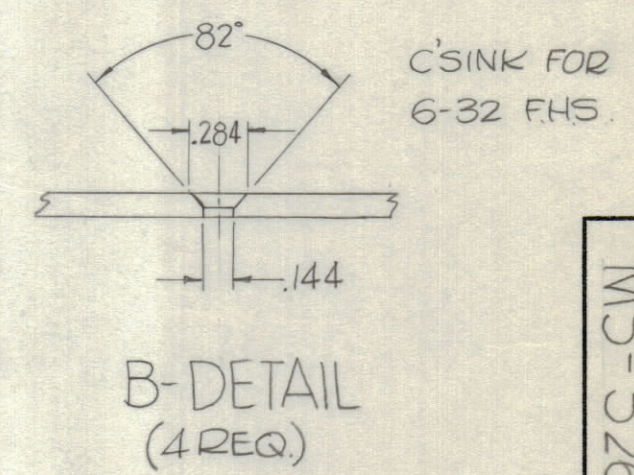
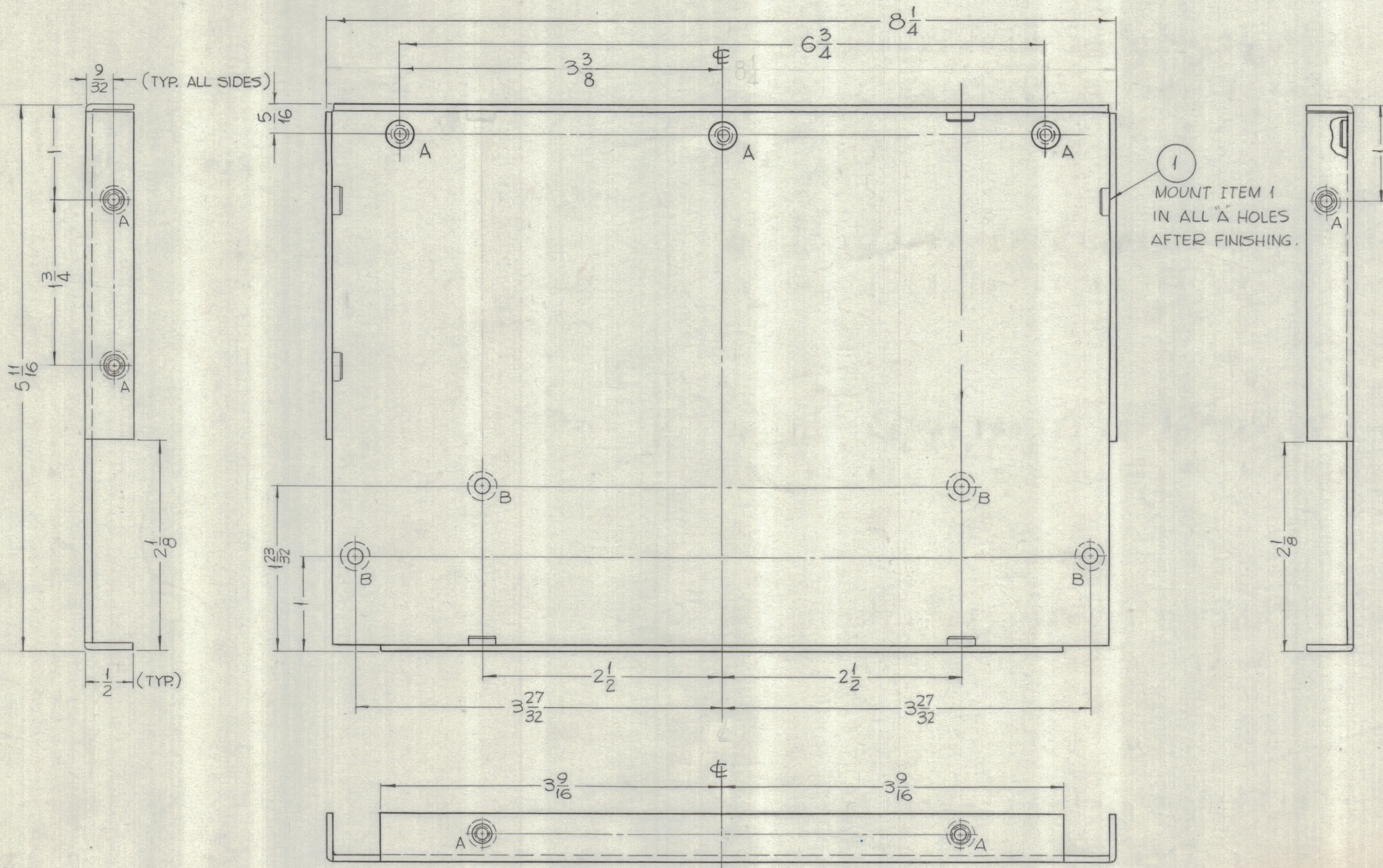

MS-3269

NOTE:
- USE MATERIAL THICKNESS FOR MAXIMUM RADIUS ON ALL BENDS.
- ALL ANGLES 90°

NOTES

1	GPT-200K	AZ-101
QTY./UNIT	MODEL USED ON	ASS'Y. NO.
SCALE 1:1	CODE A	
THE CONTENTS OF THIS DRAWING ARE THE EXCLUSIVE PROPERTY OF THE TECHNICAL MATERIEL CORP. ITS UNAUTHORIZED USE OR REPRODUCTION IN WHOLE OR IN PART IS STRICTLY FORBIDDEN.		

9	1	NT-129-0632-4	NUT ROUND, SWAGE TYPE	A
REQ'D.	ITEM	PART NUMBER	DESCRIPTION	SYMBOL
F. BUDETTI LIST OF MATERIAL				
MATERIAL .064 THICK ALUMINUM 5052 - H32			THE TECHNICAL MATERIEL CORP. MAMARONECK, NEW YORK	
FINISH S404 YELLOW IRIDITE			TITLE PLATE, SIDE RIGHT	
DRAWN SRG		DATE 5-10-63	FINAL APPROVAL	
CHECKED JWB		DATE 2/11/64	DATE	
ELECT. DES. JWB		DATE 2/11/64	MS-3269	
MECH. DES. JWB		DATE 2/11/64	SHEET	
DECIMALS .X ± .05 .XX ± .01 .XXX ± .005			FRACTIONS ± 1/64 ANGLES ± 0° 30'	
TOLERANCES			REV. LTR.	