

THE CONTENTS OF THIS DRAWING ARE THE EXCLUSIVE PROPERTY OF THE TECHNICAL MATERIEL CORP. ITS UNAUTHORIZED USE FOR REPRODUCTION IN WHOLE OR IN PART IS STRICTLY FORBIDDEN.

REQ. PER UNIT

2

USED ON

MODEL

GPT-200K

ASS'Y. NO.

AS-124

DATE

1-15-63

MS-3210

0

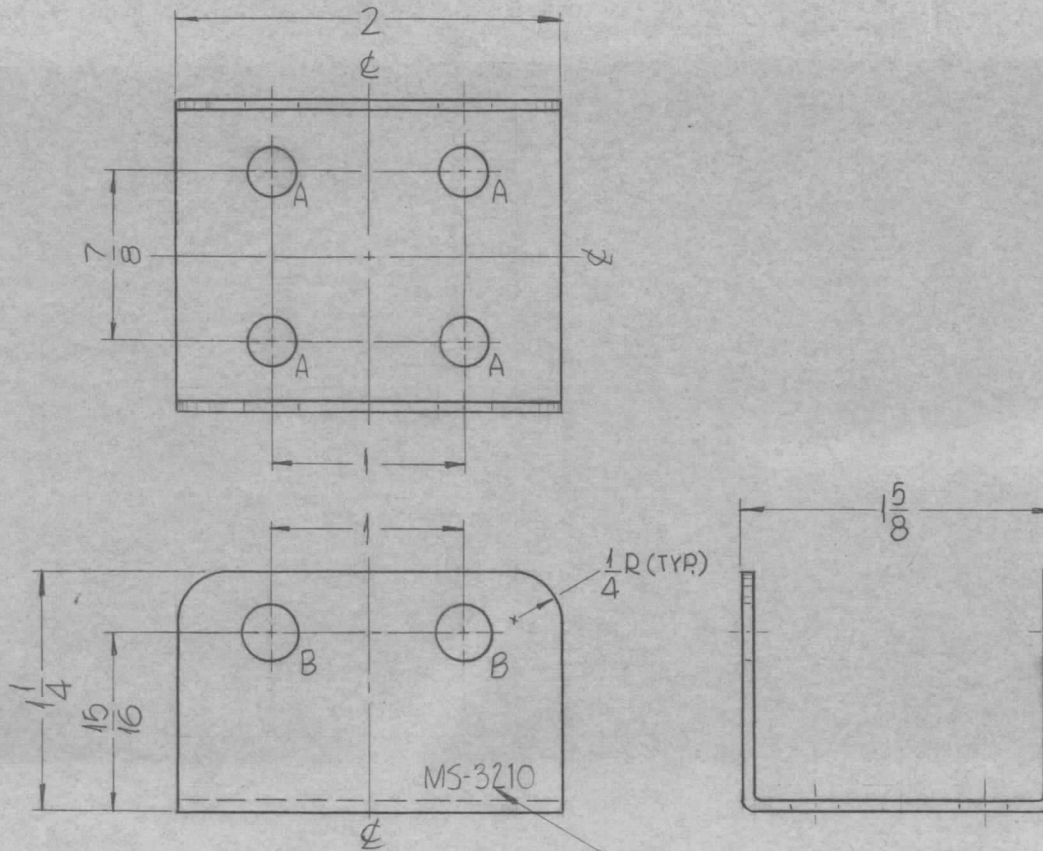

METAL STAMP TMC PART NO. 1/8 HIGH GOTHIC.

HOLES: REQ.  
A ~ 15/64 DIA. 4  
B ~ 9/32 DIA. 4

UNLESS OTHERWISE SPECIFIED:

1. USE MATERIAL THICKNESS FOR MAXIMUM RADIUS ON ALL BENDS.
2. ALL ANGULAR BENDS 90°.
3. REMOVE ALL BURRS AND SHARP EDGES.
4. - POLISH BEFORE PLATING.

REQ.	ITEM	PART NO.	F. BUDETTI			DESCRIPTION	SYMBOL
		1/16 THICK				THE TECHNICAL MATERIEL CORP. MAMARONECK, NEW YORK	0
		STOCK SIZE					
		COPPER				BRACKET, SUPPORT WAFER	
		MATERIAL					
0	ORIG. RELEASE FOR PROD.	5-16-64	SRG				
SYM	DESCRIPTION	DATE	CH. NO.	DRAFTS	CHECKER	ENG. APP.	
UNLESS OTHERWISE SPECIFIED DIMENSIONS ARE IN INCHES AND INCLUDE CHEMICALLY APPLIED OR PLATED FINISHES		SCALE	1"=1"				
DECIMALS .X ± .05 .XX ± .01 .XXX ± .005	TOLERANCES	FRACTIONS ± 1/64 ANGLES ± 0° 30'	CODE				
		TYPE & TEMPER	HEAT TREAT. SPEC.	DRAWN	CHECKED	FINAL APPROVAL	
		SILVER PLATE .0003		SRG	aa	RR	
		FINISH & SPEC. NO.	ELEC. DES. APP.	MECH. DES. APP.	MS-3210 0		