

REVISIONS						
SYM	DESCRIPTION	DATE	E.M.N. NO.	DRAFT	CHKD	APPD

$\frac{13}{32}$ DIA 2 HOLES

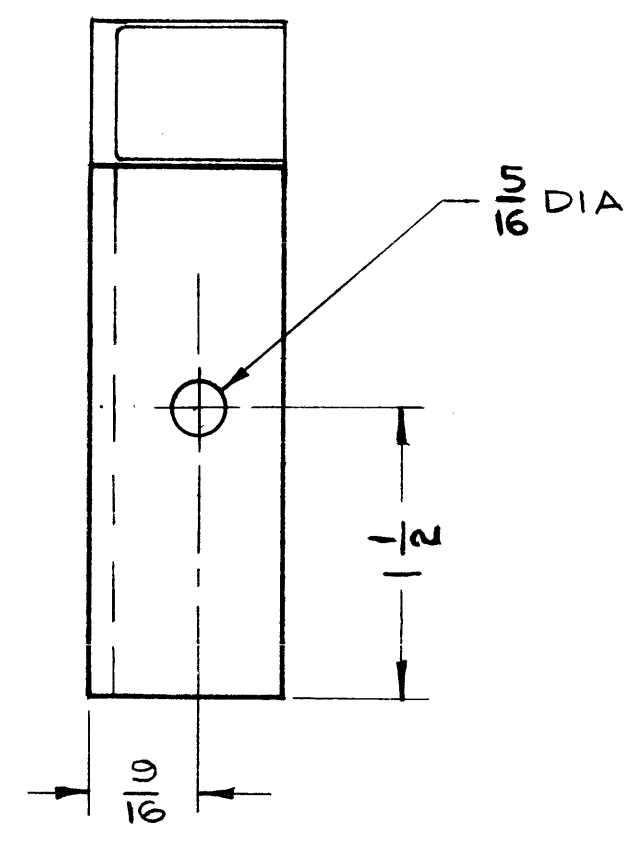
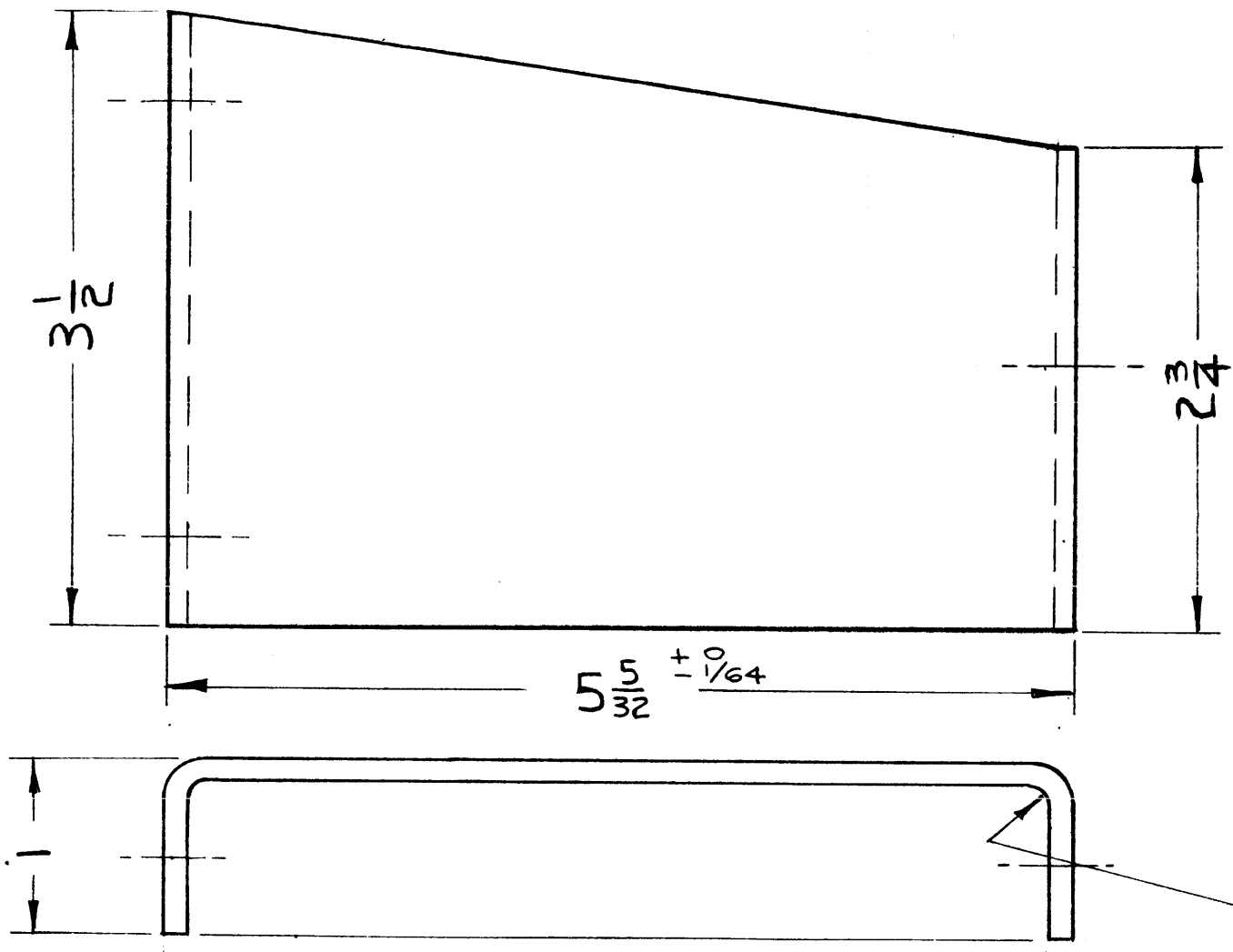
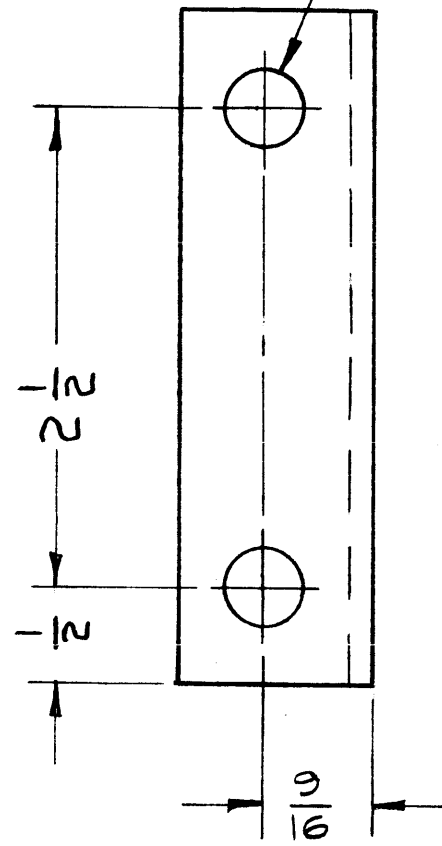

NOTES:

1. REMOVE ALL BURRS & SHARP EDGES.
2. FINISH: 1) DEGREASE & CLEAN.
2) APPLY PRIMER PER TMC SPEC S-520.
3) ONE COAT BLU-GREY VINYL NON-TEXTURED, PER TMC SPEC S-520.

TMC PART NO.	DESCRIPTION	REQ'D PER UNIT	
		RAK-21B	RAK-22A
MS-3105 -1	AS SHOWN (L. SIDE)	2	
MS-3105 -2	OPP HAND (R. SIDE)	2	

REQ'D.	ITEM	PART NUMBER	DESCRIPTION	SYMBOL
KRUY LIST OF MATERIAL				
MATERIAL		THE TECHNICAL MATERIEL CORP. MAMARONECK, NEW YORK		
STEEL SHEET 1/8 THK		TITLE BRACKET, MOUNTING		
FINISH		SEE NOTE		
UNLESS OTHERWISE SPECIFIED DIMENSIONS ARE IN INCHES AND INCLUDE CHEMICALLY APPLIED OR PLATED FINISHES		DRAWN <i>MB</i>	DATE 12-6-62	FINAL APPROVAL <i>BP</i>
		CHECKED <i>AO</i>	DATE 3/29/63	DATE
		ELECT. DES.	DATE	MS-3105
		MECH. DES. <i>T. Guy</i>	DATE 1-3-63	SHEET
				REV. LTR.

SEE TABLE	DDR-5	ASS'Y. NO.
Q'TY./UNIT	MODEL USED ON	
SCALE 1:1	CODE	
THE CONTENTS OF THIS DRAWING ARE THE EXCLUSIVE PROPERTY OF THE TECHNICAL MATERIEL CORP. ITS UNAUTHORIZED USE OR REPRODUCTION IN WHOLE OR IN PART IS STRICTLY FORBIDDEN.		

NOTES