

MS-3073-0

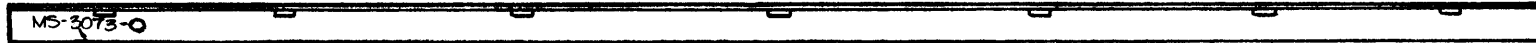

METAL STAMP TMC NO. MS-3073-0
1/8 GOTHIC.

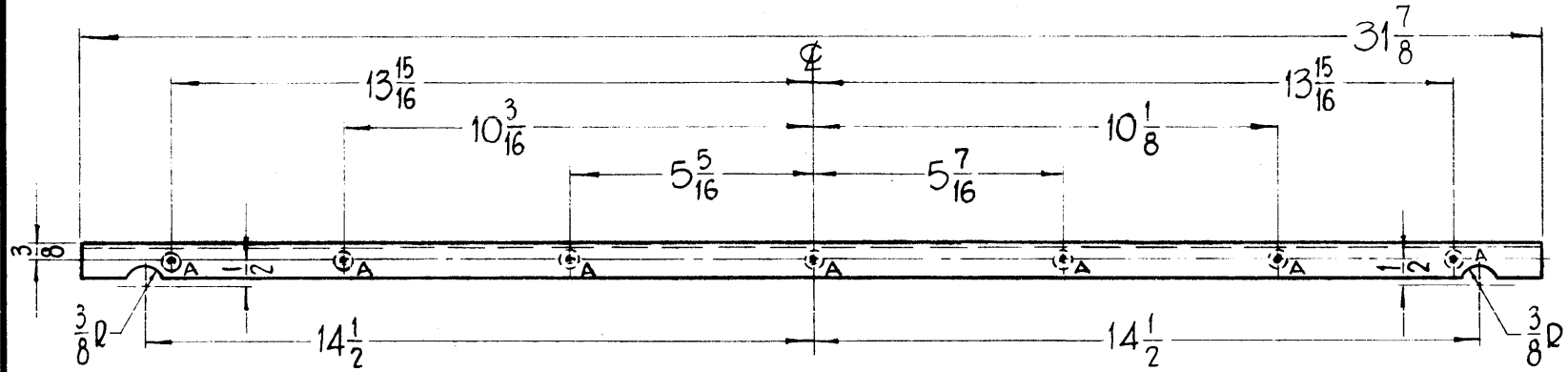

REVISIONS

SYM	DESCRIPTION	DATE	E.M.N. NO.	DRAFT	CHKD	APPD
0	ORIGINAL RELEASE FOR PRODUCTION	3-2-64		A.M.		

HOLES —

A - .253 MAX., .250 MIN. DIA'S. FOR _____ 7 DEQ.
MTG. NT-129-1032-6

REQ'D.	ITEM	PART NUMBER	DESCRIPTION	SYMBOL
7	1	NT-129-1032-6	NUT, ROUND, SWAGE TYPE	A

F. BUDETTI

LIST OF MATERIAL

MATERIAL 3/4 X 3/4 X 1/8 THICK ALUMINUM, 6061-T-6	TITLE STIFFENER, TOP
---------------------------------------------------------	-------------------------

FINISH S-404-IRIDITE	THE TECHNICAL MATERIEL CORP. MAMARONECK, NEW YORK
-------------------------	------------------------------------------------------

MOUNT INSERTS AFTER FINISHING.

1	GPT-200K	AX-398
Q'TY./UNIT	MODEL USED ON	ASS'Y. NO.
SCALE +	CODE A	

UNLESS OTHERWISE SPECIFIED
DIMENSIONS ARE IN INCHES AND INCLUDE
CHEMICALLY APPLIED OR PLATED FINISHES

DRAWN John C. Biele	DATE 1-2-63	FINAL APPROVAL RJC	DATE
CHECKED JCB	DATE 2/10/64		
ELECT. DES. JCB	DATE 2/10/64	MS-3073	0
MECH. DES. JCB	DATE 2/3/64	SHEET	REV. LTR.

THE CONTENTS OF THIS DRAWING ARE THE EXCLUSIVE PROPERTY
OF THE TECHNICAL MATERIEL CORP. ITS UNAUTHORIZED USE OR
REPRODUCTION IN WHOLE OR IN PART IS STRICTLY FORBIDDEN.

DECIMALS .X ± .05 .XX ± .01 .XXX ± .005	TOLERANCES	FRACTIONS ± 1/64 ANGLES ± 0° 30'
--------------------------------------------------	------------	-------------------------------------------

NOTES