

REVISIONS							
ZONE	SYM	DESCRIPTION	DATE	E.M.N. NO.	DRAFT	CHKD	APPD

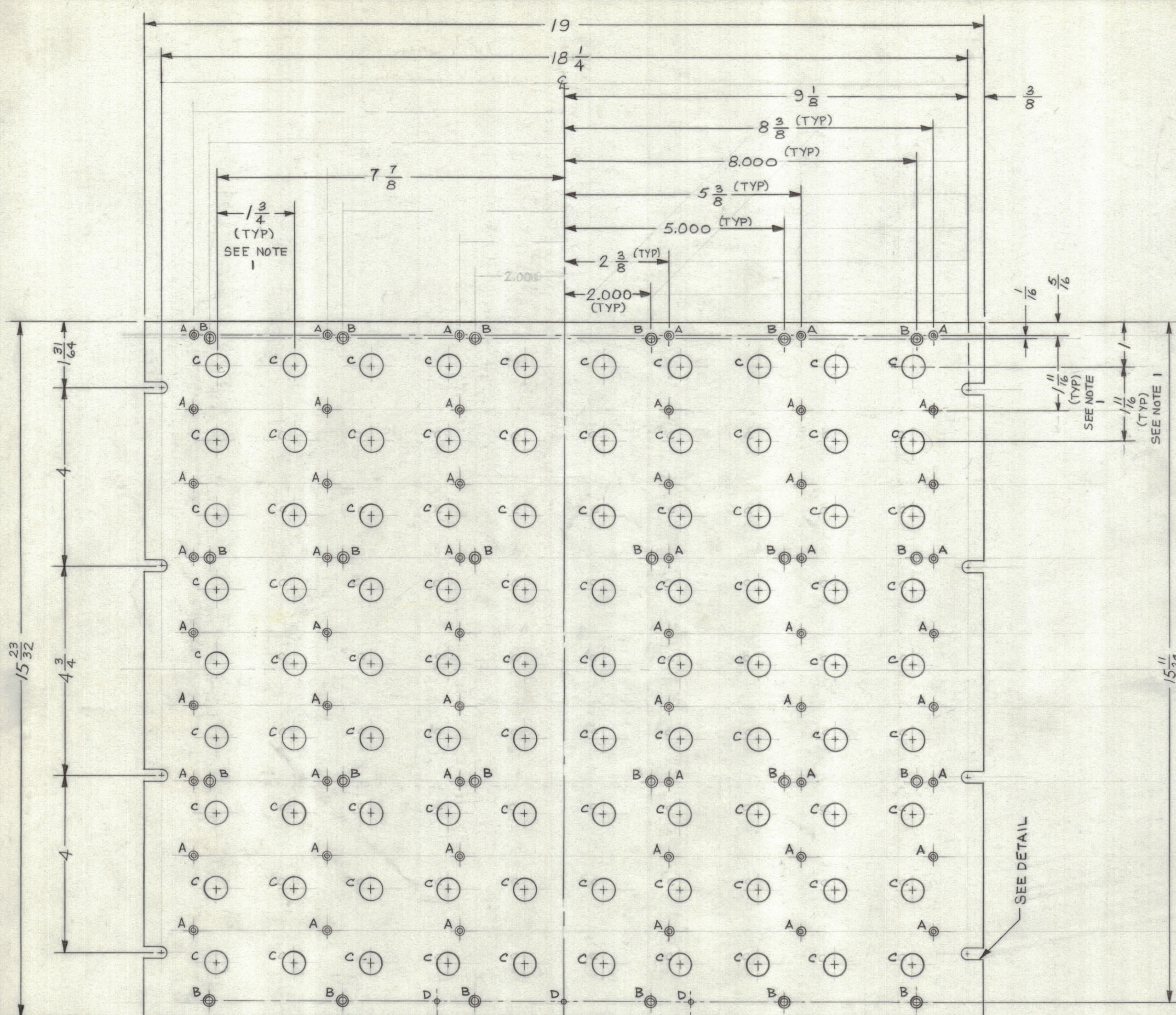

HOLE	DESCRIPTION	REQ
A	SEE DETAIL C'SINK	54
B	SEE DETAIL C'SINK	24
C	.515 DIA.	90
D	.0785 DIA.	3

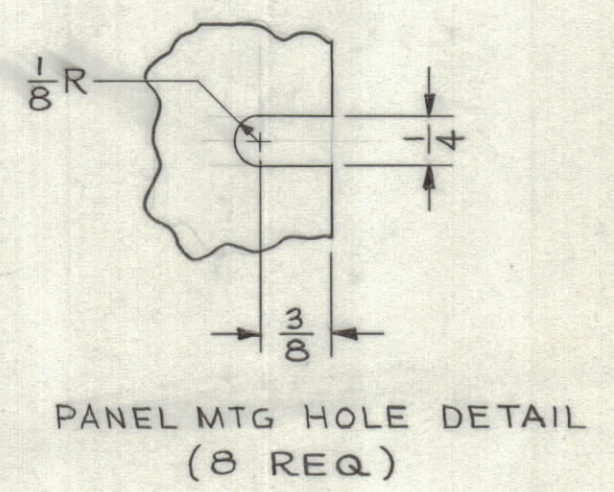
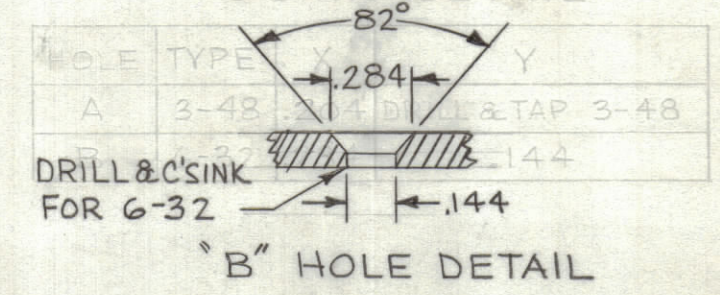
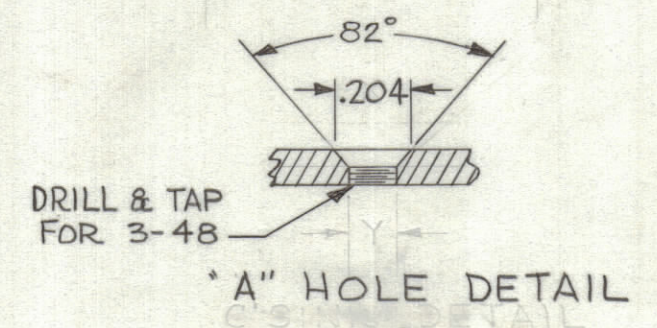

- MACHINING NOTES:**
- LATERAL BOW OF PANEL MUST BE KEPT .031 TOLERANCE.
 - MILL ALL EDGES.
 - HOLES MUST BE FREE OF ALL MACHINING MARKS, GOUGES AND SCRATCHES. IF NECESSARY, SAND FRONT OF PANEL WITH No. 120 GRIT SANDPAPER.

- FINISHING NOTES:**
- S 404 IRIDITE
 - S 114 ZINC CHROMATE PRIMER
 - S 115 TMC SMOOTH GRAY ENAMEL OR PRIME & PAINT TO CUST. SPEC
- FRONT AND EDGES ONLY

NOTES:

- TOLERANCE ARE NOT ACCUMULATIVE.

Q'TY./UNIT	QDP-4J3X90	MODEL USED ON	ASSY. NO.
SCALE	DO NOT SCALE	CODE	S-401-184

THE CONTENTS OF THIS DRAWING ARE THE EXCLUSIVE PROPERTY OF THE TECHNICAL MATERIEL CORP. ITS UNAUTHORIZED USE OR REPRODUCTION IN WHOLE OR IN PART IS STRICTLY FORBIDDEN.

REQ'D.	ITEM	PART NUMBER	DESCRIPTION	SYMBOL
MARTINENGO LIST OF MATERIAL				
MATERIAL 3/16 ALUMINUM 2024-T3			THE TECHNICAL MATERIEL CORP. MAMARONECK, NEW YORK	
FINISH SEE FINISHING NOTES			TITLE PANEL, FRONT MACHINING	
DRAWN M TANTILLO		DATE 11-14-62	FINAL APPROVAL <i>Stell</i>	
CHECKED <i>phle</i>		DATE 12/10/62	DATE 12/10/62	
ELECT. DES.		DATE	MS-3042	
MECH. DES. <i>abu</i>		DATE 12/10/62	SHEET	
DECIMALS .X ± .05 .XX ± .01 .XXX ± .005		FRACTIONS ± 1/64 ANGLES ± 0° 30'		REV. LTR.

MS-3042