

FRONT OF PANEL SHOWN

METAL STAMP TMC PART NO. 1/8 HIGH BLACK GOTHIC ON REAR OF PANEL, W/LATEST REVISION LETTER.

HOLE	DESCRIPTION	REQ.
A	SEE DETAIL A	1
B	SEE DETAIL C'SINK	6
C	29/64x1/4 SLOT	4
D	.070 DIA.	3
E	SEE DETAIL E	11

C'SINK DETAIL

FINISHING NOTES:
 S404 IRIDITE
 S114 ZINC CHROMATE PRIMER
 S115 TMC SMOOTH GREY ENAMEL
 OR PRIME & PAINT TO CUST. SPEC. } FRONT & EDGES ONLY

MACHINING NOTES:
 1- LATERAL BOW OF PANEL MUST BE KEPT TO .031 TOL.
 2- MILL ALL EDGES.
 3- HOLES MUST BE DRILLED
 4- PANEL MUST BE FREE OF ALL MACHINING MARKS, GOUGES & SCRATCHES. IF NECESSARY, SAND FRONT OF PANEL WITH NO.120 GRIT SANDPAPER.

HOLE	TYPE	X	Y	Z
A	3-48			DRILL TAP 3-48
B	6-32	.144	.144	

E DETAIL

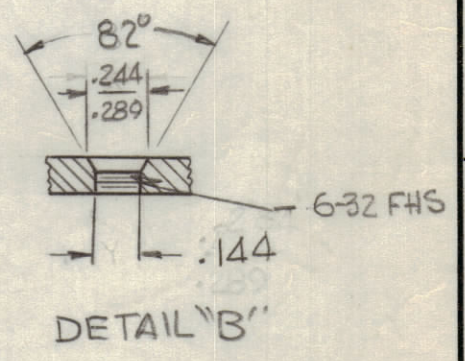

DETAIL "B"

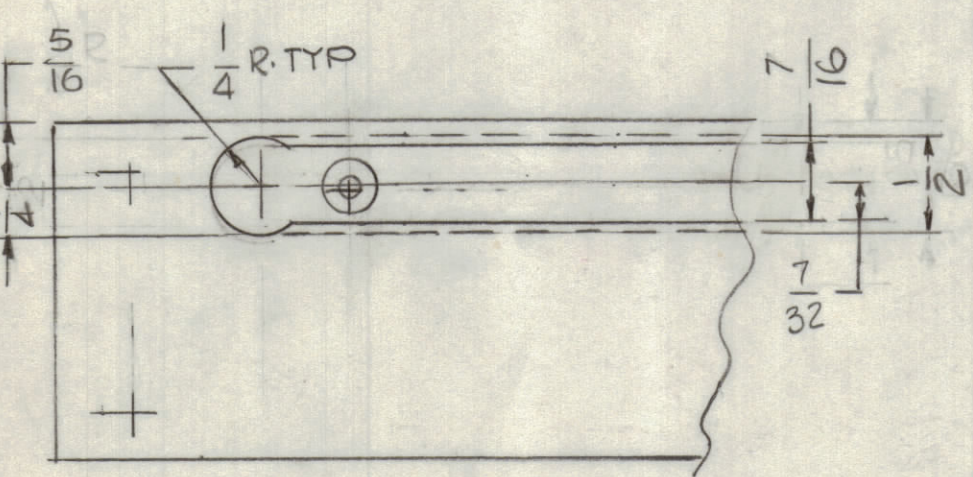

DETAIL "A"

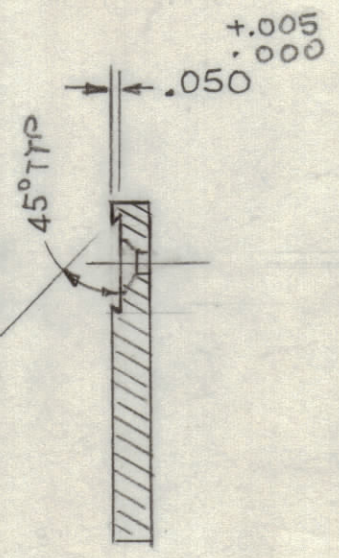

SYMBOL	ZONE	DESCRIPTION	DATE	CH. NO.	DRAFTS	CHECKER	ENG. APP.
B		"A" HOLES DELETED (DRILL & TAP FOR 3-48) DETAIL "A" ADD.	3-29-83			GDL	
A		DIM. & HOLE CHART CLARIFIED, ADD'N W/LAT REV. TO TMC NO.	10.4.66	16968	UW		

UNLESS OTHERWISE SPECIFIED:
 DIMENSIONS ARE IN INCHES
 TOLERANCES ON FRACTIONS ± 1/64 DECIMALS ± .005 ANGLES ± 1/2°
 SCALE DO NOT SCALE
 MAXIMUM ALLOWABLE TOLERANCES HAVE BEEN DETERMINED AND ANY DEVIATIONS WILL BE CAUSE FOR REJECTION. REMOVE ALL BURRS & SHARP EDGES

REQ. PER UNIT	MODEL	SECTION	ASS'Y. NO.	DATE
1	JPP-6AGX8			4-26-62

REQ. ITEM	PART NO.	DESCRIPTION	SYMBOL
	3/16	PRITCHARD	
	ALUMINUM	THE TECHNICAL MATERIEL CORP. MAMARONECK, NEW YORK	
	2024-T3	PANEL, FRONT MACHINING	
	SEE FINISHING NOTES	FINISH & SPEC. NO.	

DRAWN: P. Juchin, CHECKED: A. J., FINAL APPROVAL: BT
 MS2954 B