

| REVISIONS | | | | | | |
|-----------|-----|-------------|------|------------|-------|-----------|
| ZONE | SYM | DESCRIPTION | DATE | E.M.N. NO. | DRAFT | CHKD APPD |
| | | | | | | |

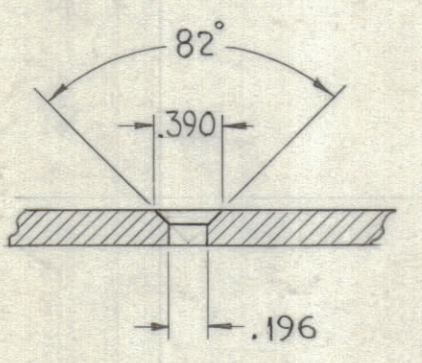

| LEGEND | | |
|--------|-------------------|------|
| HOLE | DESCRIPTION | REQ. |
| A | SEE DETAIL | 4 |
| B | SEE DETAIL | 4 |
| C | 11/64 DIA. | 4 |
| D | .076 DIA. | 4 |
| E | 15/32 DIA. | 1 |
| F | SLOT (SEE DETAIL) | 4 |

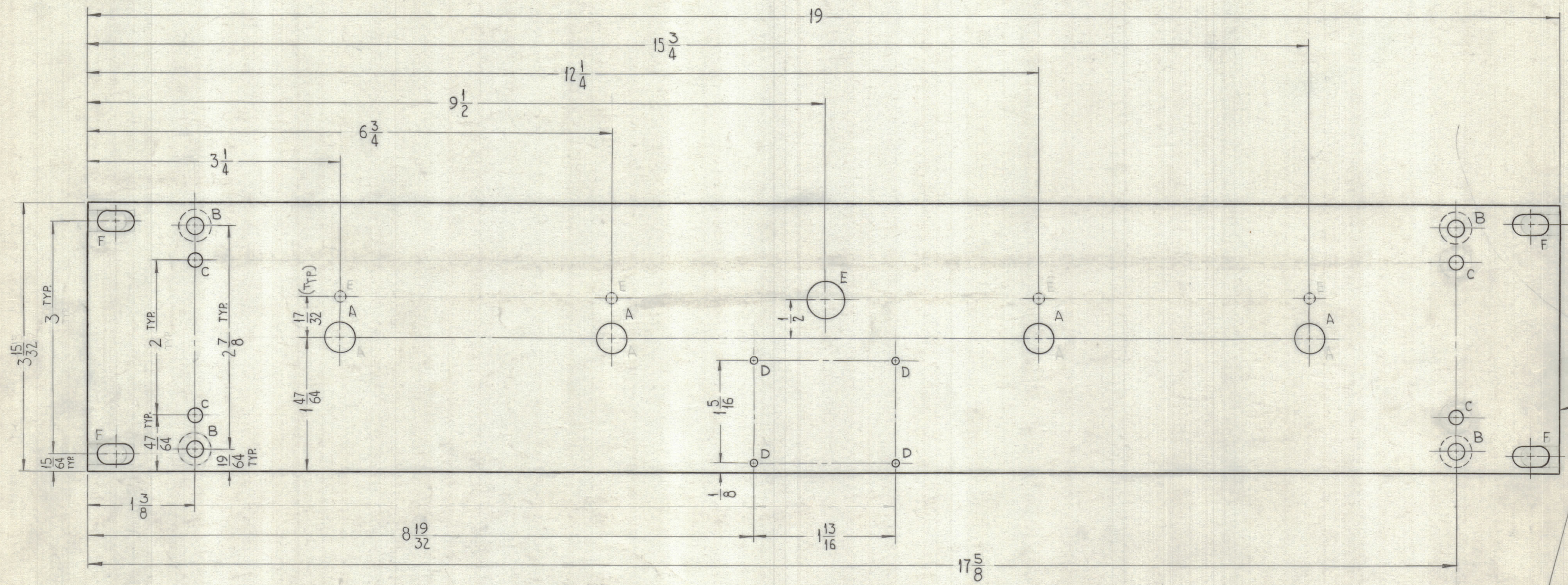
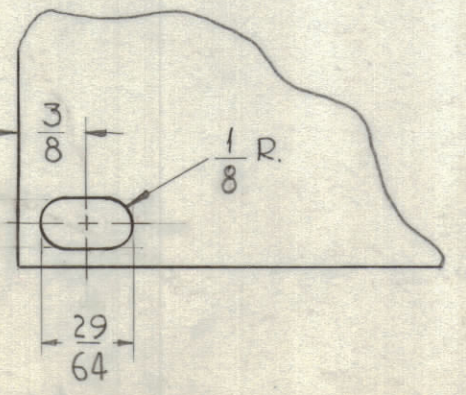
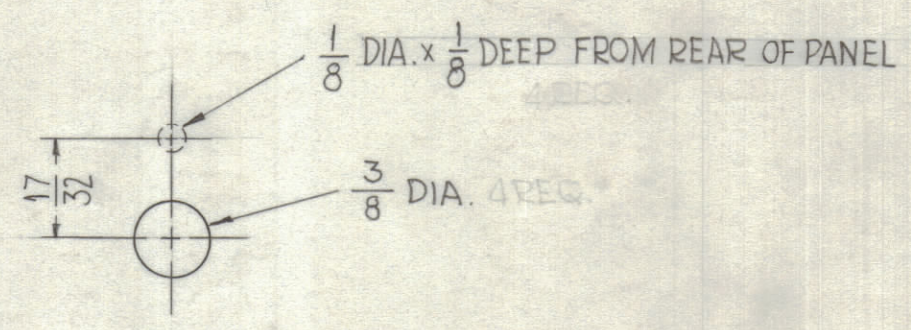

MACHINING ~
1-LATERAL BOW OF PANEL MUST BE KEPT TO .031 TOL TOLERANCE.
2-MILL ALL EDGES.
3-HOLES MUST BE DRILLED
4-PANEL MUST BE FREE OF ALL MACHINING MARKS, GOUGES & SCRATCHES.

FINISH ~
S404 YELLOW IRIDITE
S114 ZINC CHROMATE PRIMER } FRONT &
S115 TMC SMOOTH GREY ENAMEL } EDGES ONLY

NOTES

THE CONTENTS OF THIS DRAWING ARE THE EXCLUSIVE PROPERTY OF THE TECHNICAL MATERIEL CORP. ITS UNAUTHORIZED USE OR REPRODUCTION IN WHOLE OR IN PART IS STRICTLY FORBIDDEN.

METAL STAMP TMC PART NO ON REAR 1/8" HIGH GOTHIC.

NOTICE TO PERSONS RECEIVING THIS DRAWING
THE TECHNICAL MATERIEL CORPORATION claims proprietary right in the material disclosed herein. This drawing is issued in confidence for engineering information only and may not be reproduced or used to manufacture anything shown hereon without permission from THE TECHNICAL MATERIEL CORPORATION to the user. This drawing is loaned for mutual assistance and is subject to recall at any time.

Property of:
THE TECHNICAL MATERIEL CORPORATION
MAMARONECK, NEW YORK

REF. TMC DWG. LD-1093
LD-1109

| REQ'D. | ITEM | PART NUMBER | DESCRIPTION | SYMBOL |
|---|-----------|------------------|--|-----------|
| LIST OF MATERIAL | | | | |
| MATERIAL | 3/16 | ALUMINUM 2024-T3 | THE TECHNICAL MATERIEL CORP. MAMARONECK, NEW YORK | |
| FINISH | SEE NOTES | | TITLE PANEL, FRONT, MACHINING | |
| 1 | HSP-2 | | DRAWN | SRG |
| 1 | HSP-1 | | DATE | 5-16-62 |
| UNLESS OTHERWISE SPECIFIED DIMENSIONS ARE IN INCHES AND INCLUDE CHEMICALLY APPLIED OR PLATED FINISHES | | | CHECKED | HJC |
| DECIMALS .X ± .05 .XX ± .01 .XXX ± .005 | | | DATE | 22 MAY 62 |
| FRACTIONS ± 1/64 ANGLES ± 0° 30' | | | ELECT. DES. | RK |
| TOLERANCES | | | MECH. DES. | RK |
| | | | DATE | 22 MAY 62 |
| | | | SHEET | MS-2951 |
| | | | DATE | |
| | | | FINAL APPROVAL | BT |
| | | | DATE | |
| | | | REV. LTR. | |

MS-2951