

MOUNT ITEM "1" IN "D" HOLES AFTER FINISHING.

MOUNT IN ALL "E" HOLES AFTER FINISHING

METAL STAMP TMC PART NO. 1/8 HIGH GOTHIC AS SHOWN, WITH LATEST REVISION LETTER.

USE MATERIAL THICKNESS FOR MAX. RADIUS ON ALL BENDS UNLESS OTHERWISE SPECIFIED

MOUNT INSERTS AFTER FINISHING

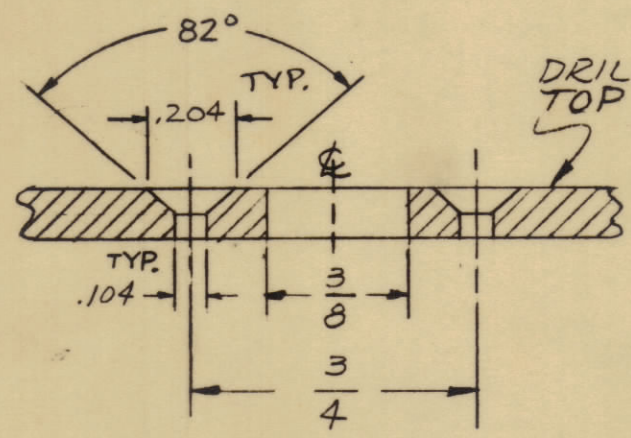
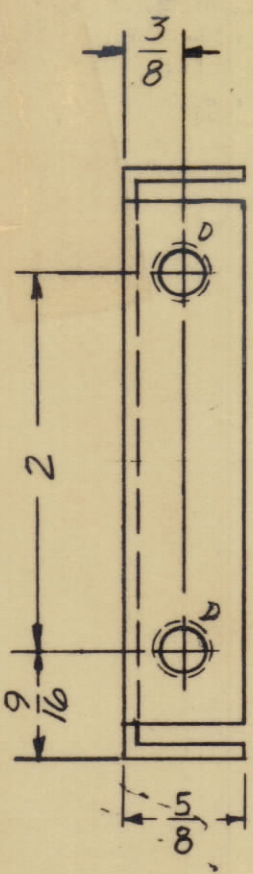

DETAIL - A FOR #3-48 SCREWS

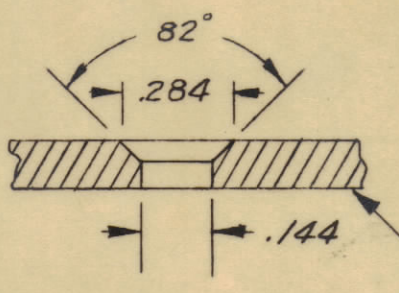

DETAIL - B DRILL & C'SINK FOR #6-32 SCREW

LEGEND

HOLE	DESCRIPTION	QUAN.
A	SEE DETAIL	4
B	SEE DETAIL	4
C	DELETED	#
D	.191 -.194 DIA.	2
E	.250 -.253 DIA	3

NOTICE TO PERSONS RECEIVING THIS DRAWING

THE TECHNICAL MATERIEL CORPORATION claims proprietary right in the material disclosed hereon. This drawing is issued in confidence for engineering information only and may not be reproduced or used to manufacture anything shown hereon without permission from THE TECHNICAL MATERIEL CORPORATION to the user. This drawing is loaned for mutual assistance and is subject to recall at any time.

Property of:  
THE TECHNICAL MATERIEL CORPORATION  
MAMARONECK, NEW YORK

SYM	ZONE	DESCRIPTION	DATE	CH. NO.	DRAFTS	CHECKER	ENG. APP.
D	C3	ON HOLE LEGEND "C" DELE., "E" ADDED	7.30.64	11986	WB		
	B3-	IT2 ADD., ON PICT. 3 "C" HOLES CHNG. TO "E" HOLES					
C	-	DWG UPDATED & CLARIFIED	12/14/63	10618			
B	F4	ADDED (3) "C" HOLES	7.26.63	9659	AR		
A	A5	MODEL AFC-2A, 1 REQ DELETED	9.27.62	7241	GS		

UNLESS OTHERWISE SPECIFIED:  
DIMENSIONS ARE IN INCHES  
TOLERANCES ON  
FRACTIONS ± 1/64    DECIMALS ± .005    ANGLES ± 1/2°

SCALE Do NOT SCALE

MAXIMUM ALLOWABLE TOLERANCES HAVE BEEN DETERMINED AND ANY DEVIATIONS WILL BE CAUSE FOR REJECTION. REMOVE ALL BURRS & SHARP EDGES

REQ. PER UNIT	MODEL	SECTION	ASS'Y. NO.	DATE
1	AFC-3			7-26-62

REQ.	ITEM	PART NO.	DESCRIPTION	SYMBOL
3	2	NT-129-1032-4	NUT, ROUND, SWAGE TYPE	E
2	1	NT-129-632-4	NUT, ROUND, SWAGE TYPE	D
WESCHLER				
.064 THICK				
STOCK SIZE				
ALUMINUM				
MATERIAL				
5052-H32				
TYPE & TEMPER				
S404-YEL. IRIDITE				
FINISH & SPEC. NO.				
THE TECHNICAL MATERIEL CORP. MAMARONECK, NEW YORK				
PLATE, CHASSIS MOUNTING (LEFT SIDE)				
V. R.R.				
DRAWN				
CHECKED				
FINAL APPROVAL				
MS-2910				
SHEET OF				