

MS-2842 A

THE CONTENTS OF THIS DRAWING ARE THE EXCLUSIVE PROPERTY OF THE TECHNICAL MATERIEL CORP. ITS UNAUTHORIZED USE OR REPRODUCTION IN WHOLE OR IN PART IS STRICTLY FORBIDDEN.

HOLE5~

A - 5/32 DIA. 2Req.

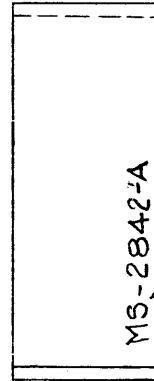
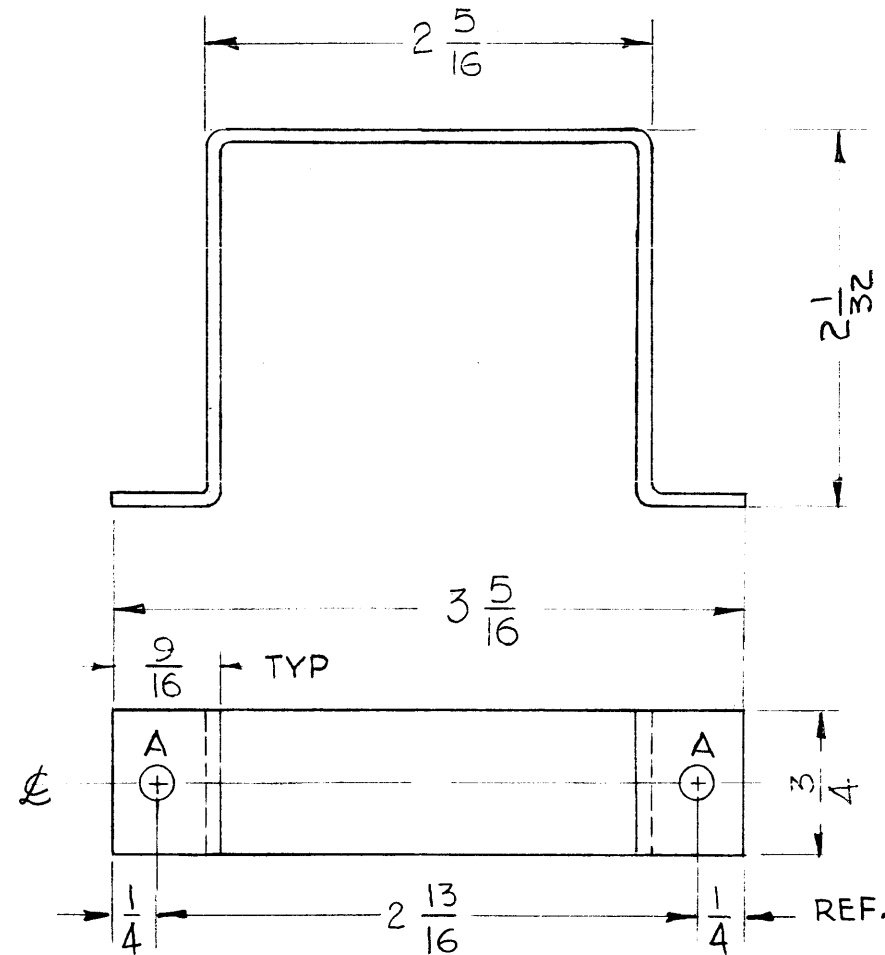

METAL STAMP TMC PART NO. MS-2842-A  
1/8 HIGH GOTHIC AS SHOWN

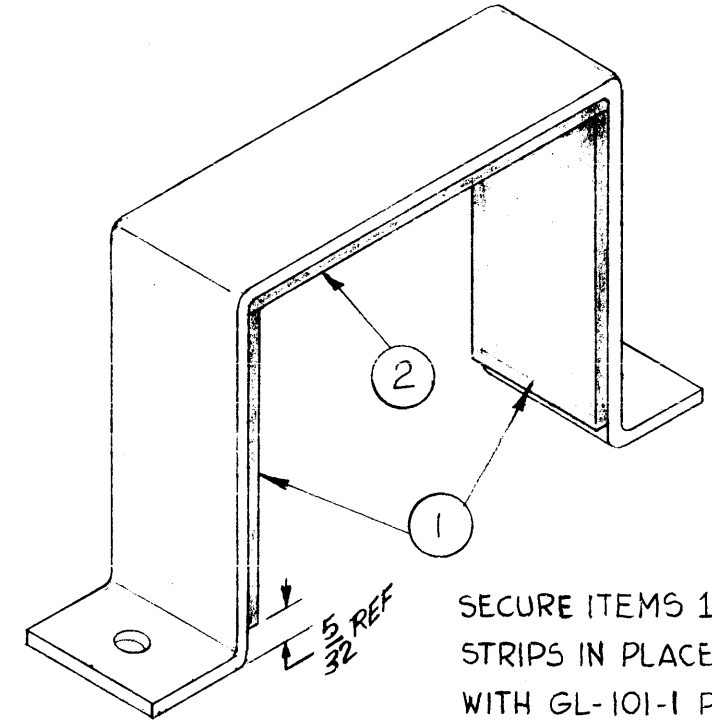

SECURE ITEMS 1 & 2, RUBBER STRIPS IN PLACE (AS SHOWN) WITH GL-101-1 PLIOBOND, ITEM 3.

— ISOMETRIC VIEW —

*[Faint, illegible text, possibly bleed-through from another drawing]*

X	3	GL-101-1	PLIOBOND	
1	2	RY-123-3	SHEET, RUBBER, 1/16" THK	
2	1	RY-123-4	SHEET, RUBBER, 1/16" THK	
REQ.	ITEM	PART NO.	DESCRIPTION	SYMBOL
.064			THE TECHNICAL MATERIEL CORP. MAMARONECK, NEW YORK	
ALUMINUM			RETAINER, FREQUENCY STANDARD	
5032-432			G.D.L.	<i>[Signature]</i>
TYPE & TEMPER		HEAT TREAT. SPEC.	DRAWN	CHECKED
S404 -YELLOW IRIDITE			<i>[Signature]</i>	<i>[Signature]</i>
FINISH & SPEC. NO.			ELEC. DES. APP.	MECH. DES. APP.

A	ON ISOMETRIC REF WAS TYP WAS 1/16	4-1-63	8684	RC	YWB	QWB
SYM	DESCRIPTION	DATE	CH. NO.	DRAFTS	CHECKER	ENG. APP.
UNLESS OTHERWISE SPECIFIED: DIMENSIONS ARE IN INCHES TOLERANCES ON FRACTIONS ± 1/64 DECIMALS ± .005 ANGLES ± 1/2°		SCALE: DO NOT SCALE MAXIMUM ALLOWABLE TOLERANCES HAVE BEEN DETERMINED AND ANY DEVIATIONS WILL BE CAUSE FOR REJECTION. REMOVE ALL BURRS AND SHARP EDGES				
		1	CSS-1A			1-18-62
		REQ. PER UNIT	MODEL	SECTION	ASS'Y. NO.	DATE
USED ON						