

THE CONTENTS OF THIS DRAWING ARE THE EXCLUSIVE PROPERTY OF THE TECHNICAL MATERIEL CORP. ITS UNAUTHORIZED USE OR REPRODUCTION IN WHOLE OR IN PART IS STRICTLY FORBIDDEN.

REQ. PER UNIT

3

USED ON

MODEL

ASS'Y. NO.

DATE

GPT-40K

AX-275

12-11-61

MS-2798

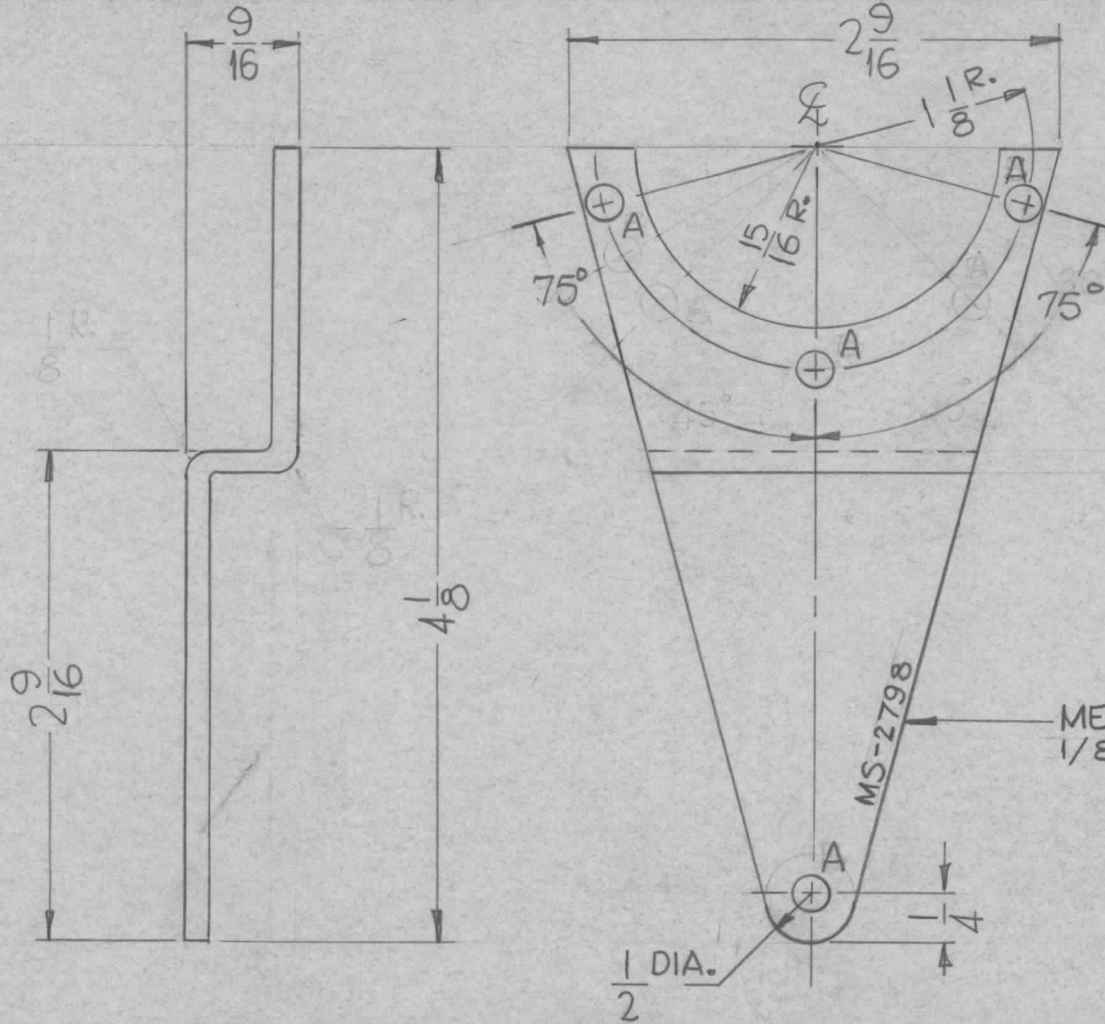

SYMBOL	DESCRIPTION	REQ.
A	3/16 DIA.	4

UNLESS OTHERWISE SPECIFIED DIMENSIONS ARE IN INCHES AND INCLUDE CHEMICALLY APPLIED OR PLATED FINISHES

DECIMALS
.X ± .05
.XX ± .01
.XXX ± .005

TOLERANCES

FRACTIONS
± 1/64
ANGLES
± 0° 30'

CUT HERE
GUARANTEED
2-66

METAL STAMP TMC PART NO. 1/8 HIGH AS SHOWN

USE MATERIAL THICKNESS FOR MAX. RADIUS ON ALL BENDS UNLESS OTHERWISE SPECIFIED

SYM	DESCRIPTION	DATE	CH. NO.	DRAFTS	CHECKER	ENG. APP.	REQ.	ITEM	PART NO.	DESCRIPTION	SYMBOL
									1/8	THE TECHNICAL MATERIEL CORP.	
									STOCK SIZE	MAMARONECK, NEW YORK	
									ALUMINUM	BRACKET, KNOB HANDLE (LARGE)	
									MATERIAL		
									5052-H32	D. J. Manno RUZZO	SPM
									TYPE & TEMPER	CHECKED	FINAL APPROVAL
									HEAT TREAT. SPEC.		
									BLACK, ANODIZED		MS-2798
									FINISH & SPEC. NO.	ELEC. DES. APP.	MECH. DES. APP.

UNLESS OTHERWISE SPECIFIED:

DIMENSIONS ARE IN INCHES

TOLERANCES ON

FRAC. ± 1/64 DEC. ± .005 ANGLES ± 1/2°

SCALE:

MAXIMUM ALLOWABLE TOLERANCES HAVE BEEN DETERMINED AND ANY DEVIATIONS WILL BE CAUSE FOR REJECTION. REMOVE ALL BURRS AND SHARP EDGES