

THE CONTENTS OF THIS DRAWING ARE THE EXCLUSIVE PROPERTY OF THE TECHNICAL MATERIEL CORP. ITS UNAUTHORIZED USE OR REPRODUCTION IN WHOLE OR IN PART IS STRICTLY FORBIDDEN.

MS-2777

HOLE LEGEND		
SYM.	DESCRIPTION	REQ'D.
A	9/16 DIA	4
B	9/16 X 1 SLOT	4

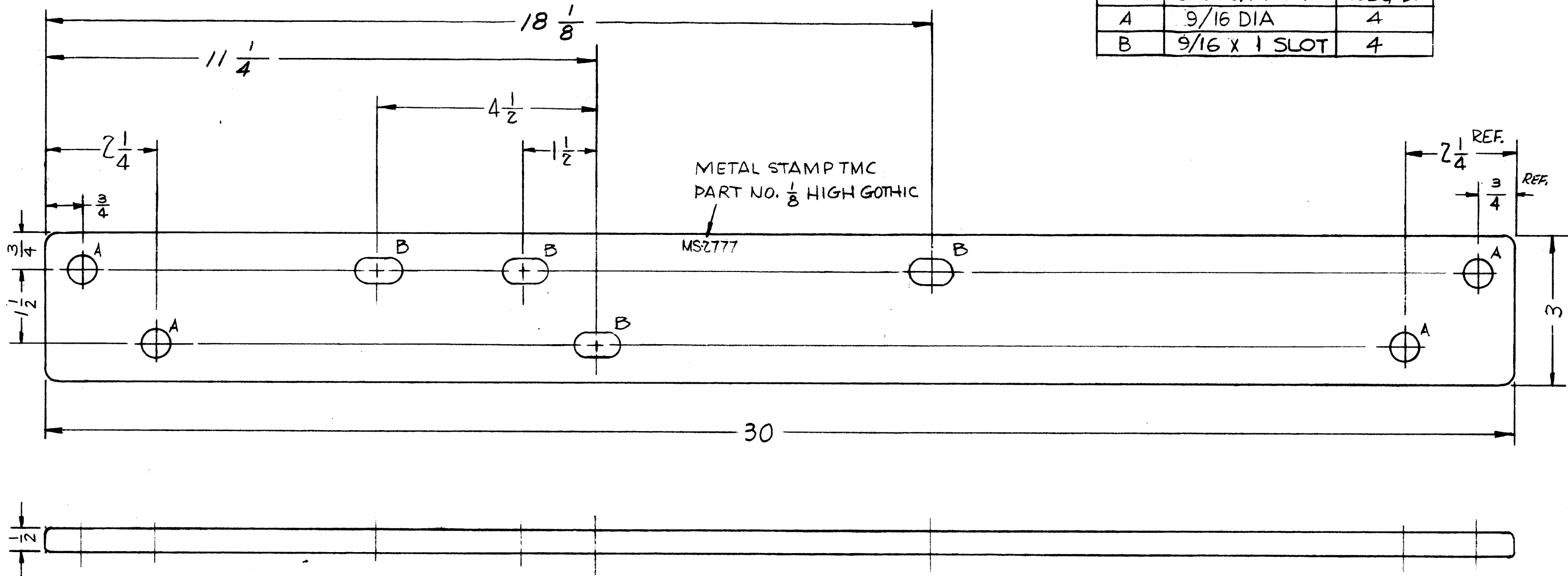

NOTE:
1- ROUND ALL CORNERS.

FINISH:
1- S404 YELLOW IRIDITE,
2- TWO COATS GREY EPOXY SPRAY,
BAKE AFTER EACH COAT.

Property of
THE TECHNICAL MATERIEL CORPORATION
MAMARONECK, NEW YORK

REQ.	ITEM	PART NO.	DESCRIPTION	SYMBOL
	1/2" THICK		THE TECHNICAL MATERIEL CORP. MAMARONECK, NEW YORK	
	STOCK SIZE			
	ALUMINUM		SUPPORT, CRADLE, BASE	
	MATERIAL			
	2024-T4		as	RUZZO
	TYPE & TEMPER	HEAT TREAT. SPEC.	DRAWN	CHECKED
	SEE NOTE		FB	MS-2777
	FINISH & SPEC. NO.		ELEC. DES. APP.	MECH. DES. APP.

SYM	DESCRIPTION	DATE	CH. NO.	DRAFTS	CHECKER	ENG. APP.
	UNLESS OTHERWISE SPECIFIED: DIMENSIONS ARE IN INCHES TOLERANCES ON FRACTIONS ± 1/64 DECIMALS ± .005 ANGLES ± 1/20					
A	SCALE: DO NOT SCALE MAXIMUM ALLOWABLE TOLERANCES HAVE BEEN DETERMINED AND ANY DEVIATIONS WILL BE CAUSE FOR REJECTION. REMOVE ALL BURRS AND SHARP EDGES					

REQ. PER UNIT	MODEL	SECTION	ASS'Y. NO.	DATE
2	TRC-20K			11-28-61

USED ON