

NOTICE TO PERSONS RECEIVING THIS DRAWING

THE TECHNICAL MATERIEL CORPORATION claims proprietary right in the material disclosed hereon. This drawing is issued in confidence for engineering information only and may not be reproduced or used to manufacture anything shown hereon without permission from THE TECHNICAL MATERIEL CORPORATION to the user. This drawing is loaned for mutual assistance and is subject to recall at any time.

Property of:
THE TECHNICAL MATERIEL CORPORATION
MAMARONECK, NEW YORK

- A - $\frac{1}{8}$ DIA. 3 REQ.
- B - $\frac{11}{64}$ DIA. 4 "
- C - $\frac{3}{8}$ DIA SLOT 1 "
- C - SEE DETAIL 2 "
- D - $\frac{191}{64}$ DIA. 1 "

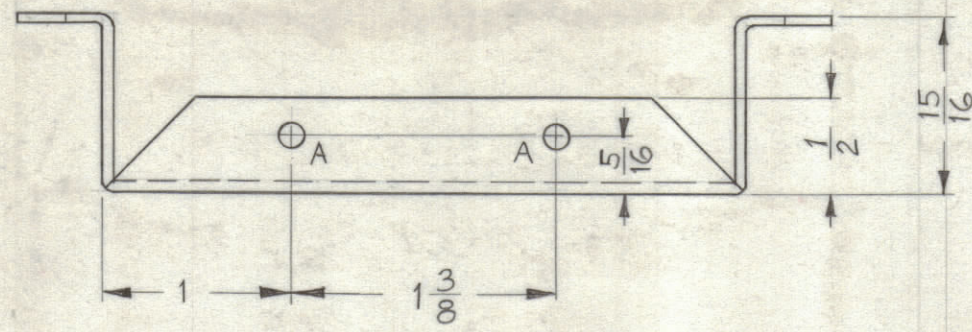

METAL STAMP TMC PART NO. AS SHOWN $\frac{1}{8}$ HIGH GOTHIC.

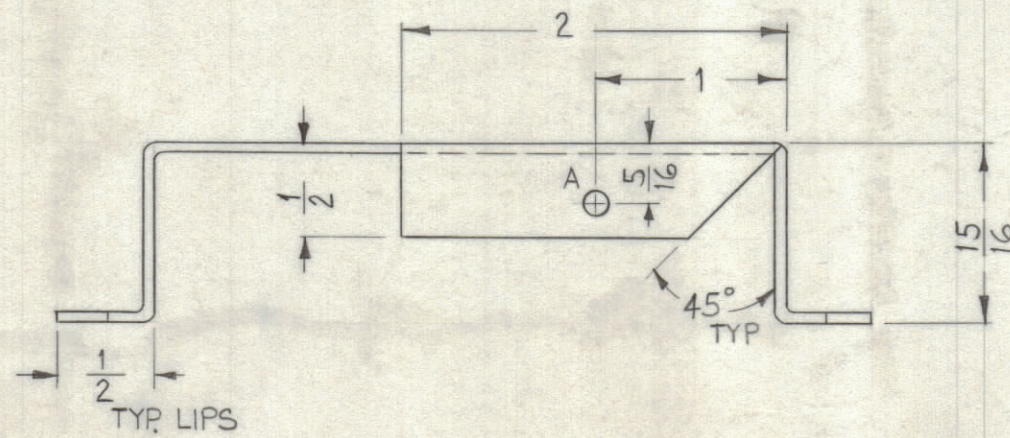
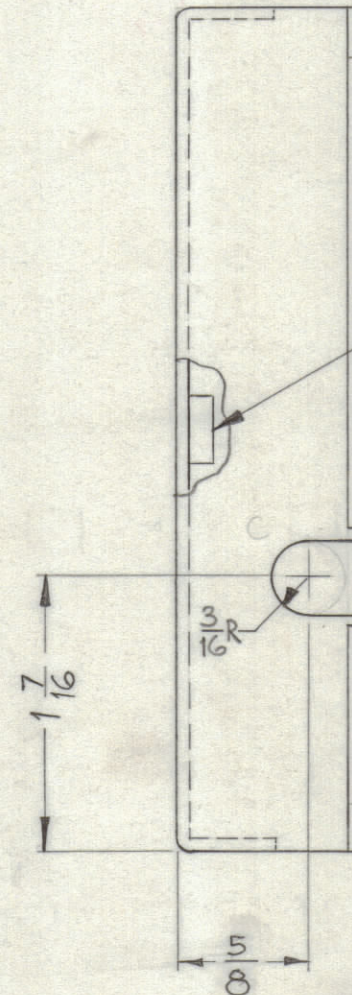
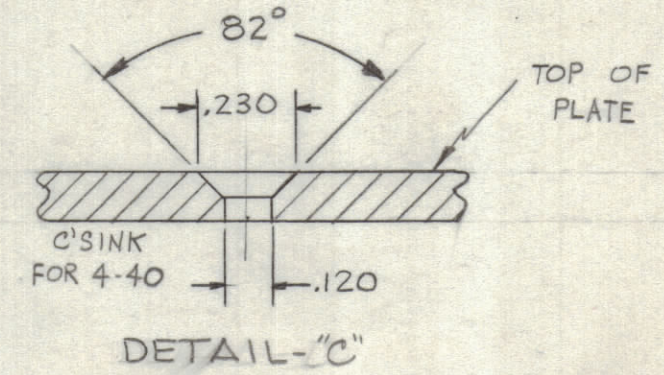
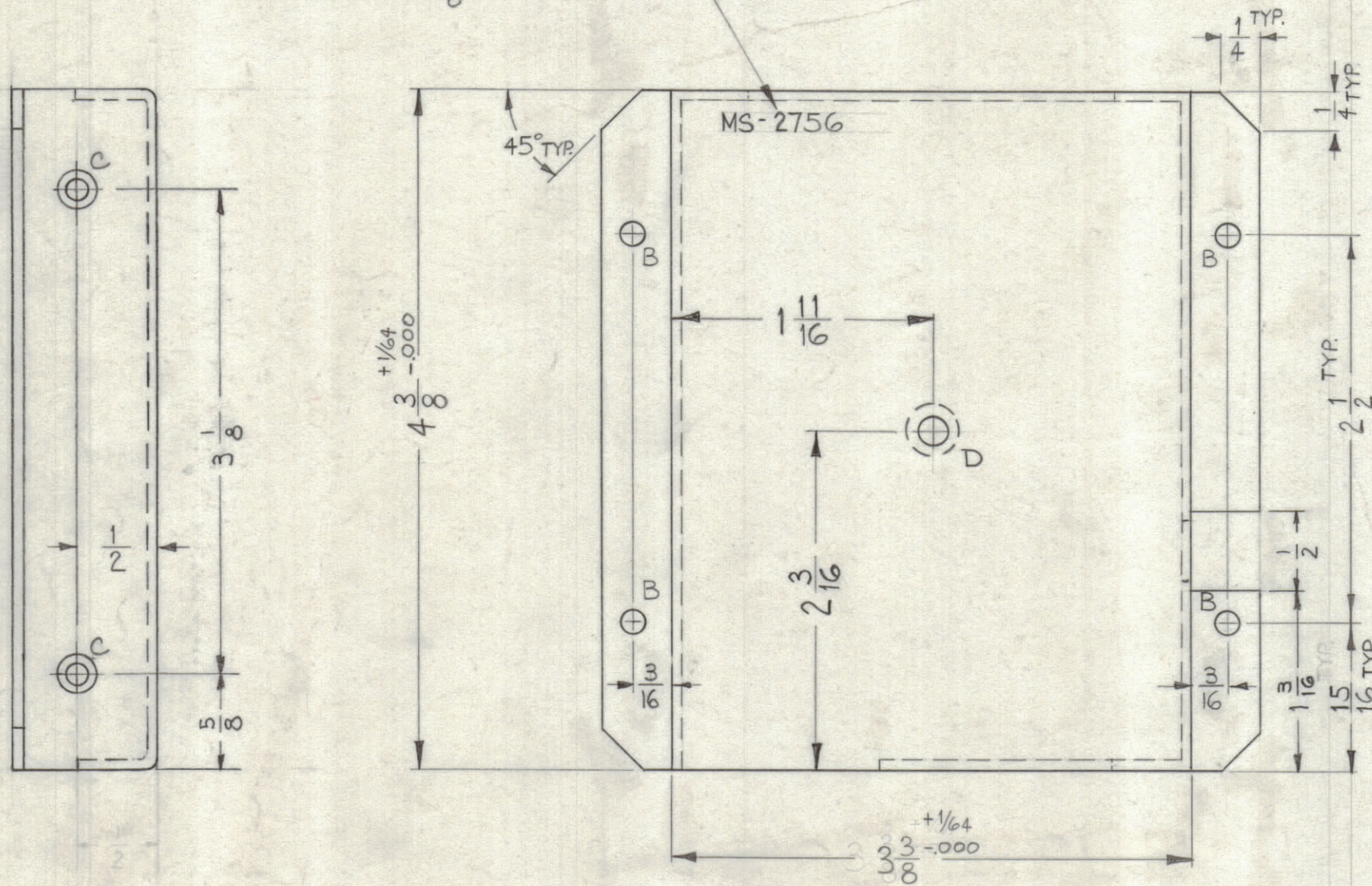

UNLESS OTHERWISE SPECIFIED DIMENSIONS ARE IN INCHES AND INCLUDE CHEMICALLY APPLIED OR PLATED FINISHES

DECIMALS .X ± .05 .XX ± .01 .XXX ± .005	FRACTIONS ± 1/64 ANGLES ± 0° 30'
--	---

TOLERANCES

1	1	NT-129-632-4	NUT, ROUND, SWAGE TYPE	D
REQ. ITEM	PART NO.		DESCRIPTION	
	.064		THE TECHNICAL MATERIEL CORP. MAMARONECK, NEW YORK	
STOCK SIZE			BASE, OVEN HOUSING	
MATERIAL				
5052-H32			MAE	AW
TYPE & TEMPER			DRAWN	CHECKED
3404 YEL IRIDITE			gwt	FINAL APPROVAL
FINISH & SPEC. NO.			MS-2756	A
			ELEC. DES. APP.	MECH. DES. APP.
			SHEET	OF

1	ES	ONE IN. UNLS ADDED	12-5-61				
SYM	ZONE	DESCRIPTION	DATE	CH. NO.	DRAFTS	CHECKER	ENG. APP.
UNLESS OTHERWISE SPECIFIED: DIMENSIONS ARE IN INCHES			SCALE (DO NOT SCALE)				
TOLERANCES ON FRACTIONS ± 1/64			MAXIMUM ALLOWABLE TOLERANCES HAVE BEEN DETERMINED AND ANY DEVIATIONS WILL BE CAUSE FOR REJECTION. REMOVE ALL BURRS & SHARP EDGES				
DECIMALS ± .005			ANGLES ± 1/2°				

2	AFC-2			11-15-61
REQ. PER UNIT	MODEL	SECTION	ASS'Y. NO.	DATE
USED ON				