

ALL CORNERS ARE WELDED AND GROUND SMOOTH  
 CREASE UP

FLATTEN THIS AREA APPROX. 6" DIA.

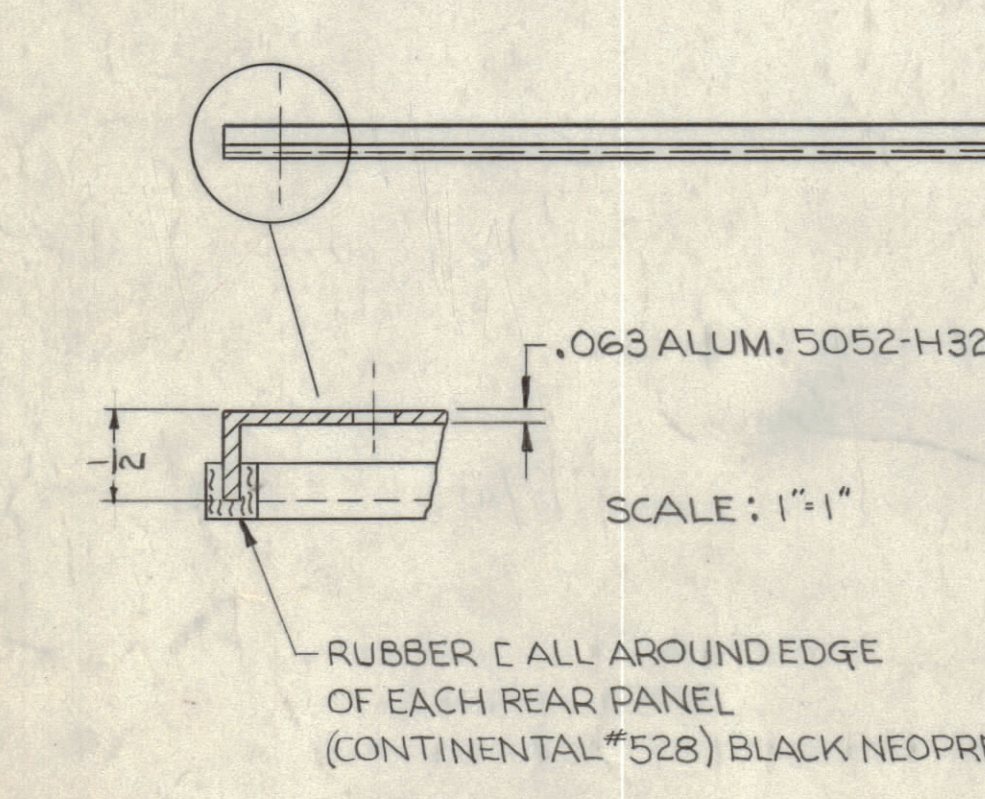

FINISH NOTE:  
 S404 IRIDITE  
 S114 ZINC CHROMATE PRIMER  
 S520 BLUE-GRAY TEXT. PAINT

NOTICE TO PERSONS RECEIVING THIS DRAWING  
 THE TECHNICAL MATERIEL CORPORATION claims proprietary right in the material disclosed herein. This drawing is issued in confidence for engineering information only and may not be reproduced or used to manufacture anything shown herein without permission from THE TECHNICAL MATERIEL CORPORATION to the user. This drawing is loaned for mutual assistance and is subject to recall at any time.  
 Property of:  
 THE TECHNICAL MATERIEL CORPORATION  
 MAMARONECK, NEW YORK

SYM	ZONE	DESCRIPTION	DATE	CH. NO.	DRAFTS	CHECKER	ENG. APP.
A	~	ADDED SURF 2x	11/30	80363	GE	MC	3/28
B	~	CREASE, FLATTEN & FINISH NOTES ADDED. 1" X HOLE DELE. 2" X HOLES RELOC. "A" WAS 3/16 DIA.	5.6.64	11373	JB	MC	3/28
UNLESS OTHERWISE SPECIFIED:		SCALE 4" = 1'-0"					
DIMENSIONS ARE IN INCHES		MAXIMUM ALLOWABLE TOLERANCES HAVE BEEN DETERMINED AND ANY DEVIATIONS WILL BE CAUSE FOR REJECTION. REMOVE ALL BURRS & SHARP EDGES					
TOLERANCES ON FRACTIONS ± 1/64		DECIMALS ± .005		ANGLES ± 1/2°		A	

REQ. PER UNIT	MODEL	SECTION	ASSY. NO.	DATE
1	GPT40KH	AX291		10-12-61
USED ON:				

REQ. ITEM	PART NO.	DESCRIPTION	SYMBOL
	.063 STOCK SIZE	ALUMINUM	
	5052-H32	TYPE & TEMPER	
		HEAT TREAT. SPEC.	
		FINISH & SPEC. NO.	
THE TECHNICAL MATERIEL CORP. MAMARONECK, NEW YORK		PANEL REAR (POWER AMPL)	
DRAWN: R. Jankin		CHECKED: [Signature]	
ELEC. DES. APP.		MECH. DES. APP.	
SHEET 1 OF 2		MS-2747 B	

MS-2747 B