

THE CONTENTS OF THIS DRAWING ARE THE EXCLUSIVE PROPERTY OF THE TECHNICAL MATERIEL CORP. ITS UNAUTHORIZED USE OR REPRODUCTION IN WHOLE OR IN PART IS STRICTLY FORBIDDEN.

REQ. PER UNIT	USED ON			MS-2737	B
	MODEL	ASS'Y. NO.	DATE		
1	AFC-2, AFC-2A		1-6-61		
1	AFC-3		4-12-62		

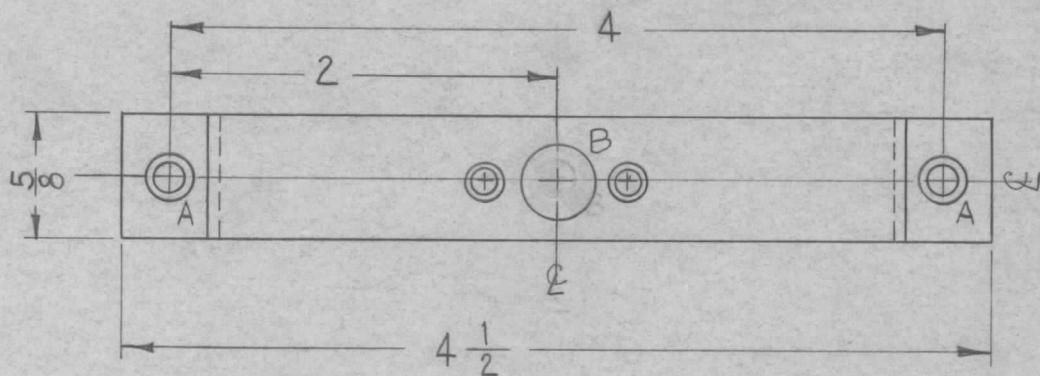

LEGEND		
HOLE	DESCRIPTION	REQ.
A	.161-.164 DIA.	2
B	SEE DETAIL	1

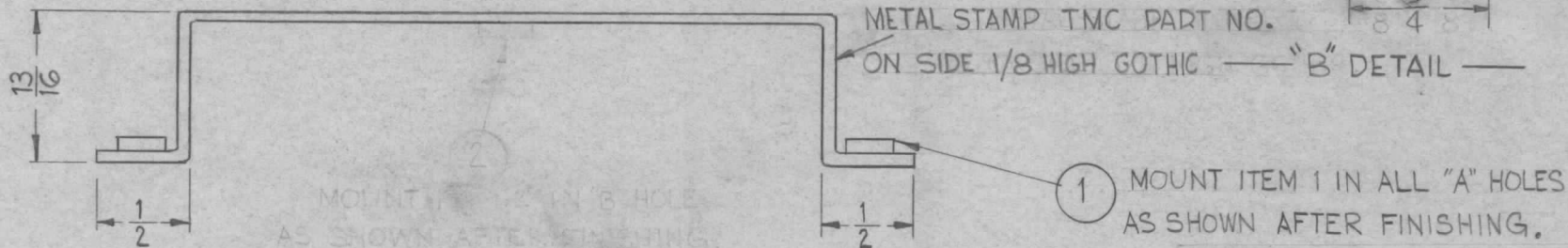
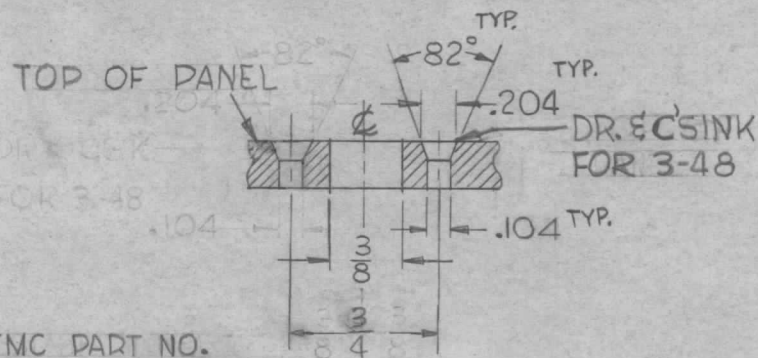

UNLESS OTHERWISE SPECIFIED DIMENSIONS ARE IN INCHES AND INCLUDE CHEMICALLY APPLIED OR PLATED FINISHES		
DECIMALS	TOLERANCES	FRACTIONS
.X ± .05		± 1/64
.XX ± .01		ANGLES ± 0° 30'
.XXX ± .005		

2	1	NT-129-440-4	NUT, ROUND, SWAGE TYPE	A
---	---	--------------	------------------------	---

SYM	DESCRIPTION	DATE	CH. NO.	DRAFTS	CHECKER	ENG. APP.	REQ. ITEM	PART NO.	DESCRIPTION	SYMBOL			
B	DELETED ITEM 2 FS-102	6-27-62	6821	R.T.	<i>[Signature]</i>	<i>[Signature]</i>		.064	THE TECHNICAL MATERIEL CORP. MAMARONECK, NEW YORK	BRACKET, BOTTOM SUPPORT			
A	Item 2 Was .191-.194 Dia. Item 2 Was NT-129-632-4	1-31-62	6281	LL	<i>[Signature]</i>	<i>[Signature]</i>		ALUMINUM					
UNLESS OTHERWISE SPECIFIED: DIMENSIONS ARE IN INCHES. TOLERANCES ON							SCALE: DO NOT SCALE		5052-H32				
FRAC. ± 1/64 DEC. ± .005 ANGLES ± 1/2°							MAXIMUM ALLOWABLE TOLERANCES HAVE BEEN DETERMINED AND ANY DEVIATIONS WILL BE CAUSE FOR REJECTION. REMOVE ALL BURRS AND SHARP EDGES		TYPE & TEMPER	HEAT TREAT. SPEC.	DRAWN	CHECKED	FINAL APPROVAL
									S404 YEL. IRIDITE		<i>[Signature]</i>	<i>[Signature]</i>	MS-2737
									FINISH & SPEC. NO.	ELEC. DES. APP.	MECH. DES. APP.		