

REQ. PER. UNIT	USED ON			MS-2587
	MODEL	ASS'Y. NO.	DATE	
1	CHG-2	OSC.	5-26-61	

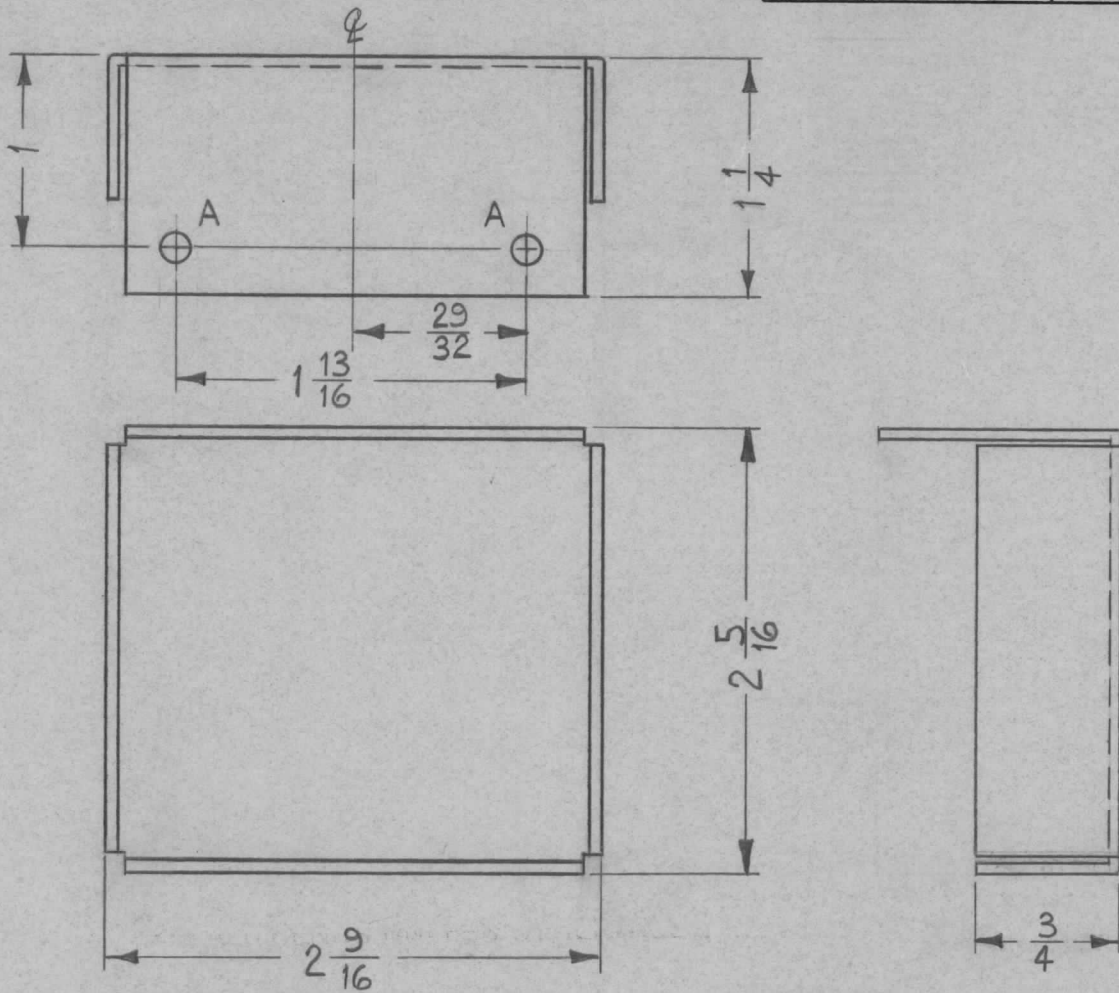

A - $\frac{5}{32}$ DIA. 2 REQ.

REF: LD-926 (1)

ISSUE	ITEM	CHANGED FROM	DATE	CH. NO.	DRAFTS	CHECKER	ENG. APP.	REQ. ITEM	PART NO.	DESCRIPTION	SYMBOL		
								.051 STOCK SIZE		THE TECHNICAL MATERIEL CORP. MAMARONECK, NEW YORK			
								ALUMINUM MATERIAL		SHIELD, TERMINAL STRIP			
								5052-H32		<i>M.A.F.</i>	<i>[Signature]</i>		
TOLERANCES			SCALE: FULL (DO NOT SCALE)					TYPE & TEMPER	HEAT TREAT. SPEC.	DRAWN	CHECKED	FINAL APPROVAL	
DEC. DIM. ±			MAXIMUM ALLOWABLE TOLERANCES HAVE BEEN DETERMINED AND ANY DEVIATIONS WILL BE CAUSE FOR REJECTION. REMOVE ALL BURRS AND SHARP EDGES					S404 YELL. IRIDITE		<i>S.D.</i>	<i>[Signature]</i>	MS-2587	
FRAC. DIM. ± 1/64								FINISH & SPEC. NO.		ELEC. DES. APP	MECH. DES. APP		
ANGULAR DIM. ±													