

REQ. PER UNIT	USED ON			MS-2342	C
	MODEL	ASS'Y. NO.	DATE		
2	GPT-40K	AX-209	7-29-60		

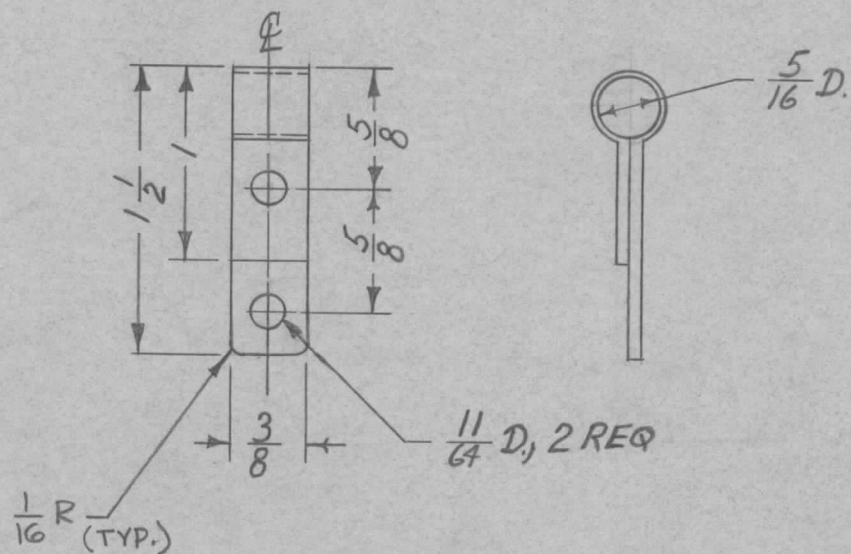

NOTICE TO PERSONS RECEIVING THIS DRAWING

THE TECHNICAL MATERIEL CORPORATION claims proprietary right in the material disclosed hereon. This drawing is issued in confidence for engineering information only and may not be reproduced or used to manufacture anything shown hereon without permission from THE TECHNICAL MATERIEL CORPORATION to the user. This drawing is loaned for mutual assistance and is subject to recall at any time.

Property of:  
**THE TECHNICAL MATERIEL CORPORATION**  
 MAMARONECK, NEW YORK

ISSUE	ITEM	CHANGED FROM	DATE	CH. NO.	DRAFTS	CHECKER	ENG. APP.	REQ.	ITEM	PART NO.	DESCRIPTION	SYMBOL					
C	1	1/16 R. ADDED	3-7-63	8432	<i>[Signature]</i>	<i>[Signature]</i>	<i>[Signature]</i>				<b>THE TECHNICAL MATERIEL CORP.</b> MAMARONECK, NEW YORK <i>STRAP, CONNECTING, 3MMF</i> <i>METERING CAPACITOR</i>						
B	1	FINISH & SPEC. NO. WAS GOLD PL. 0000 25	1-29-63	8131	G.D.L.	<i>[Signature]</i>	<i>[Signature]</i>			.015							
A	1	STOCK SIZE WAS .031	10-26-62	7560	<i>[Signature]</i>	<i>[Signature]</i>	<i>[Signature]</i>			COPPER							
										MATERIAL							
TOLERANCES			SCALE: FULL									<i>[Signature]</i>	<i>[Signature]</i>				
DEC. DIM. ±			MAXIMUM ALLOWABLE TOLERANCES HAVE BEEN DETERMINED AND ANY DEVIATIONS WILL BE CAUSE FOR REJECTION. REMOVE ALL BURRS AND SHARP EDGES					TYPE & TEMPER		HEAT TREAT. SPEC.		DRAWN	CHECKED	FINAL APPROVAL			
FRAC. DIM. ± 1/64								S-245 SILVER PLATE		S-423 SILVER KOTE IRIDITE				<i>[Signature]</i>			
ANGULAR DIM. ±								FINISH & SPEC. NO.		ELEC. DES. APP		MECH. DES. APP					
												MS-2342	C				