

REQ. PER UNIT	USED ON			MS-2293
	MODEL	ASS'Y. NO.	DATE	
2	GPT-40K	AP-104	6-7-60	

A \approx 13/64 (.203) D. 1 REQ.

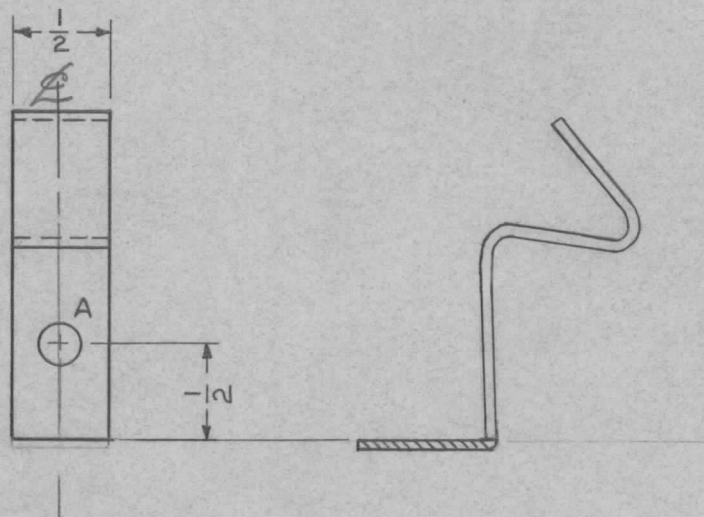

NOTE:

1. REMOVE SHADED PORTION & ADD HOLE AS SHOWN.
2. THIS BRACKET SUPPLIED W/RW-117-21 (MODIFIED AS SHOWN)
(MTG BRACKET CATALOG #815)

WARD 100F REF RW-117-21

REQ.	ITEM	PART NO.	DESCRIPTION			SYMBOL	
			THE TECHNICAL MATERIEL CORP.				
			MAMARONECK, NEW YORK				
			BRACKET, RESISTOR MTG.				
			MATERIAL				
			MATERIAL				
			MATERIAL				
			MATERIAL				
ISSUE	ITEM	CHANGED FROM	DATE	CH. NO.	DRAFTS	CHECKER	ENG. APP.
TOLERANCES			SCALE: FULL				
DEC. DIM. \pm			MAXIMUM ALLOWABLE TOLERANCES HAVE BEEN DETERMINED AND ANY DEVIATIONS WILL BE CAUSE FOR REJECTION.				
FRAC. DIM. \pm 1/64			REMOVE ALL BURRS AND SHARP EDGES				
ANGULAR DIM. \pm							
TYPE & TEMPER		HEATTREAT. SPEC.	DRAWN	CHECKED	FINAL APPROVAL		
					MS-2293		
FINISH & SPEC. NO.		ELEC. DES. APP	MECH. DES. APP				