

REQ. PER UNIT	USED ON			MS-2203
	MODEL	ASS'Y. NO.	DATE	
	2	CSS-1	4-25-60	
2	CSS-1A	1-30-62		

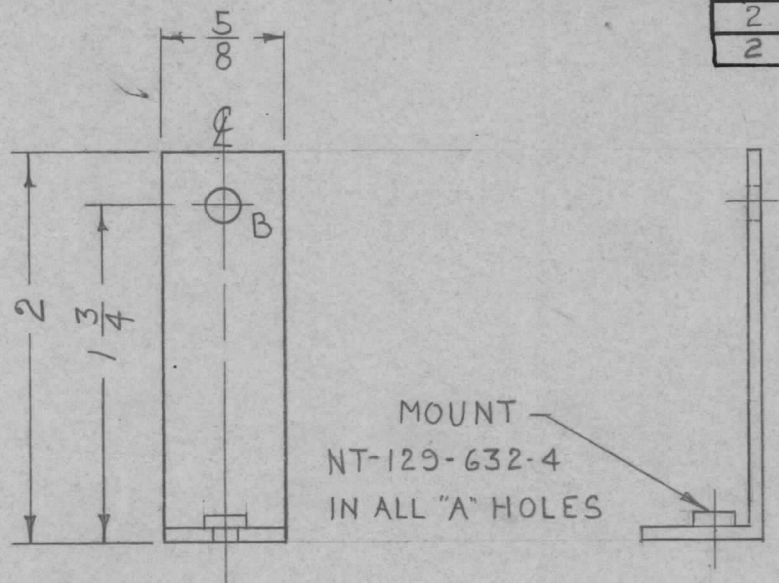

A - .191-.194 D. (FOR NT-129-632-4) 1 REQ
 B - 11/64 (.171) D. 1 "

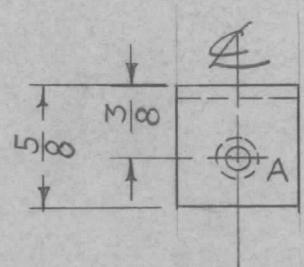
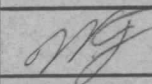
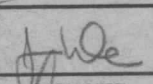
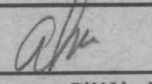
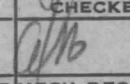

							1	1	NT-129-632-4	NUT, ROUND, SWAGE TYPE				
ISSUE	ITEM	CHANGED FROM	DATE	CH. NO.	DRAFTS	CHECKER	ENG. APP.	REQ.	ITEM	PART NO.	DESCRIPTION	SYMBOL		
									.064	THE TECHNICAL MATERIEL CORP.				
									STOCK SIZE	MAMARONECK, NEW YORK				
									ALUMINUM	BRACKET, SELENIUM RECTIFIER				
									MATERIAL					
									5052-H32	  		DRAWN	CHECKED	FINAL APPROVAL
									TYPE & TEMPER	HEAT TREAT. SPEC.		DRAWN	CHECKED	FINAL APPROVAL
									S404 YELL. IRIDITE				MS-2203	
									FINISH & SPEC. NO.	ELEC. DES. APP.		MECH. DES. APP.		
TOLERANCES			SCALE:				MAXIMUM ALLOWABLE TOLERANCES HAVE BEEN DETERMINED AND ANY DEVIATIONS WILL BE CAUSE FOR REJECTION. REMOVE ALL BURRS AND SHARP EDGES							
DEC. DIM. ±														
FRAC. DIM. ± 1/64														
ANGULAR DIM. ±														