

TMC PART NO.	PRIME OR DIP	FINISH	REQ. PER UNIT	USED ON			MS-2123	D
MS-2123-1	S114 ZINC CHROM	S220 TMC RCAP BLUE GRAY SMOOTH ENAMEL	2	MODEL	ASS'Y. NO.	DATE		
MS-2123-2	or Prime & Paint Per Customer Specs.			GPT-10K	AX-166	3-21-60		

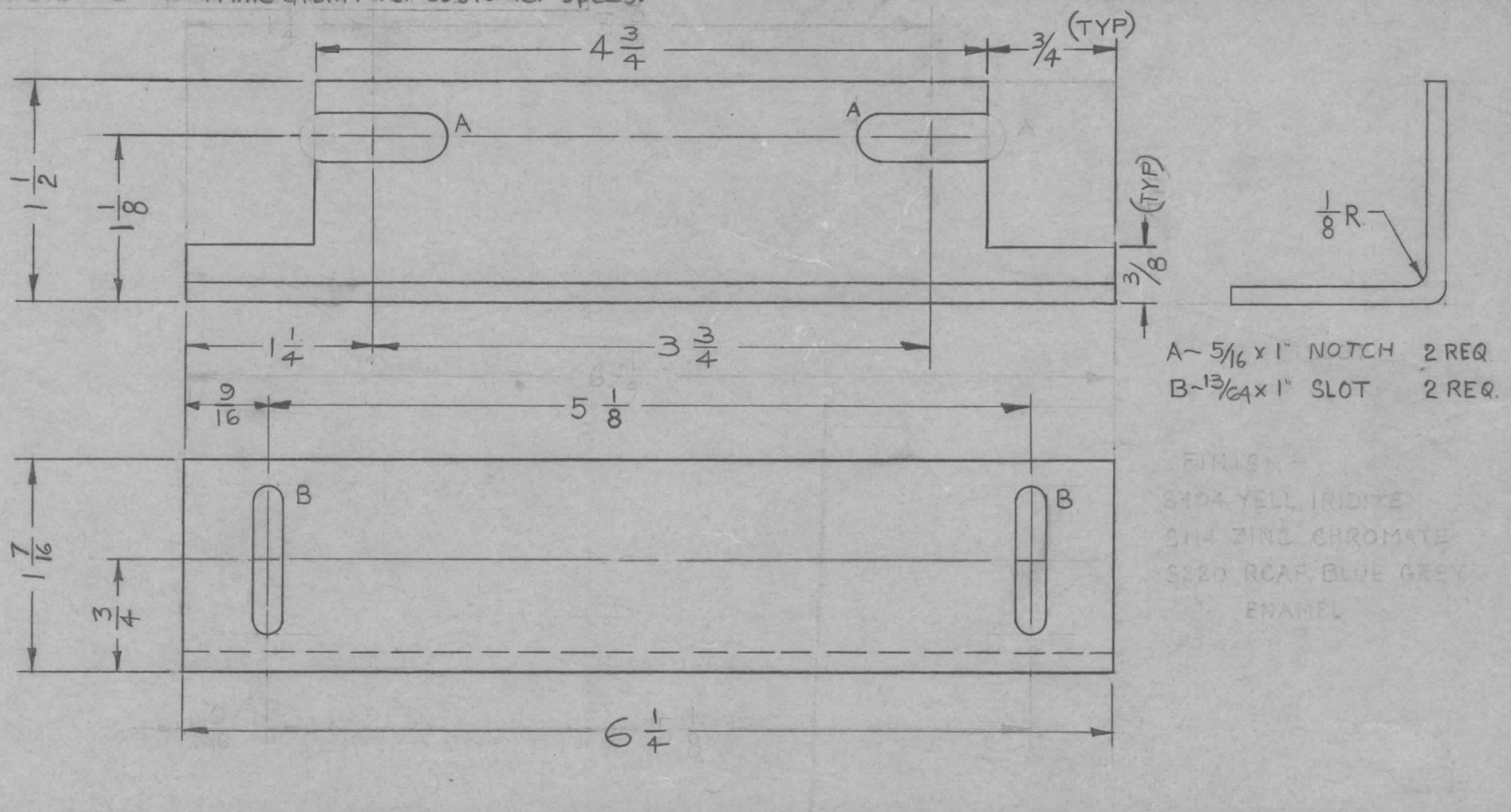

A - 5/16 x 1" NOTCH 2 REQ.
 B - 13/16 x 1" SLOT 2 REQ.

FINISH -
 S114 YELL. IRIDITE
 S114 ZINC CHROMATE
 S220 RCAP. BLUE GRAY
 ENAMEL

D	1	"B" SLOT WAS 3/16 x 1	5-20-63	9060	PH	JMB	REQ.	ITEM	PART NO.	DESCRIPTION	SYMBOL	
C	1	DRG. MODIFIED	10/18/60	3212	PH	JMB	11GA			THE TECHNICAL MATERIEL CORP. MAMARONECK, NEW YORK		
B	1	Delete 152 -2 was unger finish added cust. specs.	5-25-60	2373	PH	JMB	STEEL			BRACKET, MTG. DOOR LATCH BOTTOM, FRONT & REAR		
A	1	CHART ADDED	5-13-60	2251	PH	JMB	MATERIAL					
ISSUE	ITEM	CHANGED FROM	DATE	CH. NO.	DRAFTS	CHECKER	ENG. APP.	5082-1132		M. J.	JMB	
TOLERANCES			SCALE:				TYPE & TEMPER		HEAT TREAT. SPEC.	DRAWN	CHECKED	FINAL APPROVAL
DEC. DIM. ± FRAC. DIM. ± 1/64 ANGULAR DIM. ±			MAXIMUM ALLOWABLE TOLERANCES HAVE BEEN DETERMINED AND ANY DEVIATIONS WILL BE CAUSE FOR REJECTION. REMOVE ALL BURRS AND SHARP EDGES				SEE NOTE		FINISH & SPEC. NO.		ELEC. DES. APP MECH. DES. APP	
										MS-2123		D