

IF IT IS FOUND DESIRABLE TO CHANGE ANY TOLERANCE OR OTHER DETAIL SPECIFIED ON THIS DRAWING NOTIFY THE PURCHASER PROMPTLY.

MAXIMUM ALLOWABLE TOLERANCES HAVE BEEN DETERMINED AND DEVIATIONS WILL BE CAUSE FOR REJECTION. REMOVE ALL BURRS AND SHARP EDGES

MS-298

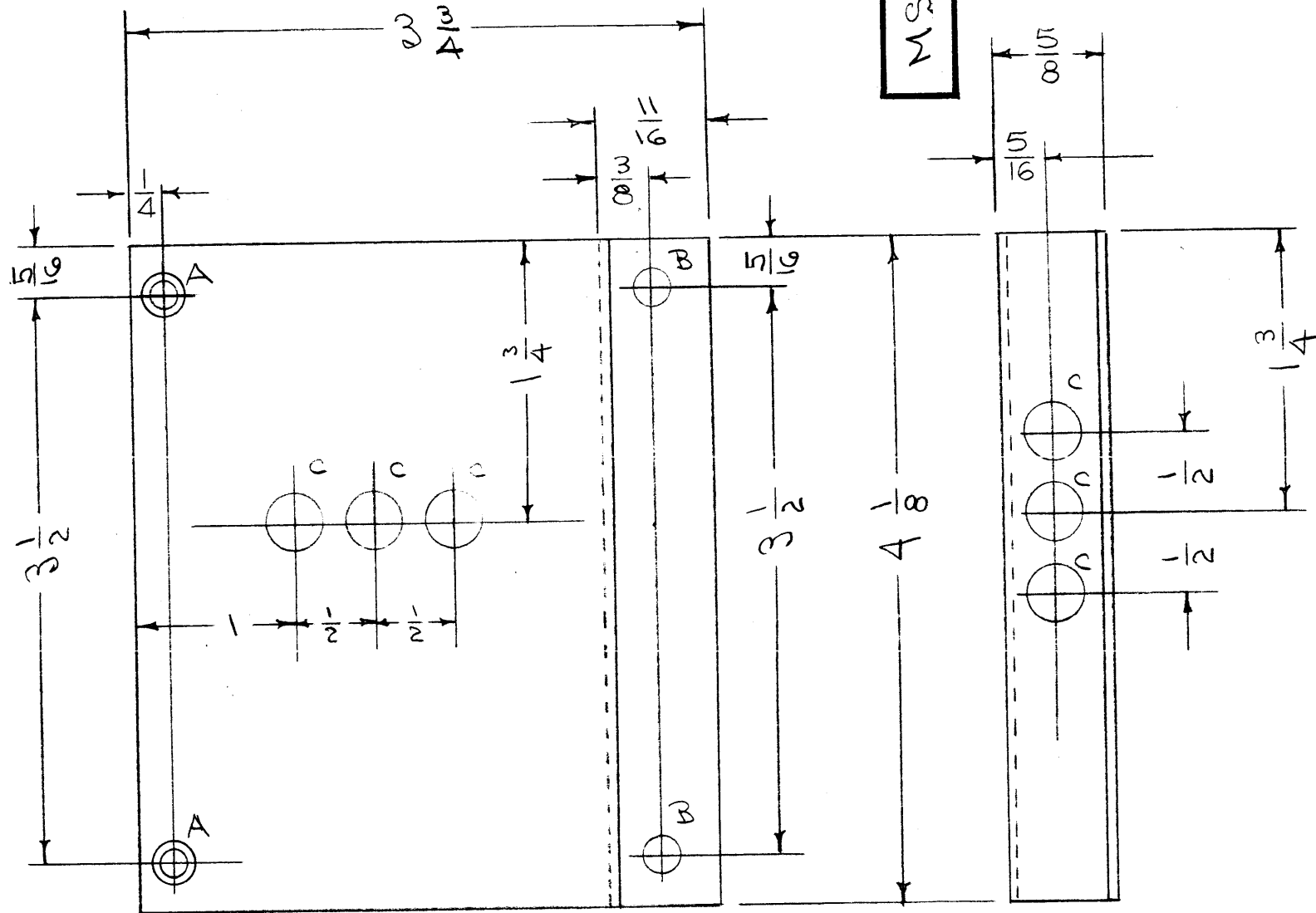

- A- SEE DETAIL 2 HOLES REQ.
- B- 1/4 (.250) D. 2 " "
- C- 3/8 (.375) D. 6 " "

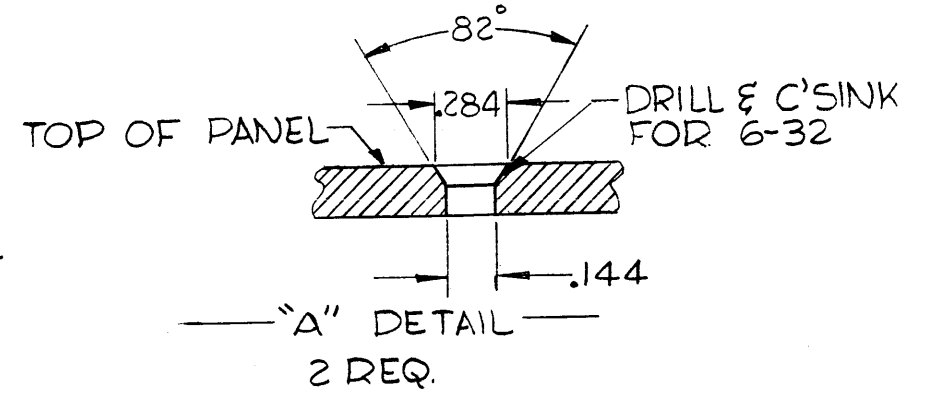

NOTICE TO PERSONS RECEIVING THIS DRAWING

THE TECHNICAL MATERIEL CORPORATION claims proprietary right in the material disclosed hereon. This drawing is issued in confidence for engineering information only and may not be reproduced or used to manufacture anything shown hereon without permission from THE TECHNICAL MATERIEL CORPORATION to the user. This drawing is loaned for mutual assistance and is subject to recall at any time.

Property of:
THE TECHNICAL MATERIEL CORPORATION
 MAMARONECK, NEW YORK

D	2	1/4 DIM. WAS 5/16; 5/8 DIM. WAS 11/16	2-9-62	6328	LE	EMN
C	1	3 WAS 3/16 DIA; 5/16 DIM. WAS 11/32	17/11/63	1001	EMN	EMN
B	1	S-404 WAS S-101	1/18/55	2	EMN	EMN
		COMPLETE REVISION				

ISSUE	ITEM	CHANGED FROM	DATE	CN. NO.	DRAFTS	CHECKER	ENG. APP.
TOLERANCES		SCALE:					
ALL OTHERS	DEC. DIM. ±	DRILL, PUNCH, COMMERCIAL STOCK					
	FRAC. DIM. ±	SIZES AND MANUFACTURERS					
	ANGULAR DIM. ±	TOLERANCES ARE NOT INCLUDED.					

1	VOX 1/2	291	1-18-55
1	VOX		1-18-55
REQ. PER UNIT	MODEL	PROJECT NO.	DATE
			ASS'Y. NO.

REQ.	ITEM	PART NO.	DESCRIPTION	SYMBOL
		.064	THE TECHNICAL MATERIEL CORP.	
		STOCK SIZE	MAMARONECK, NEW YORK	
	ALUMINUM	#	GUARD, TRANSFORMER	
	MATERIAL	WEIGHT PER PC.		
	52S H32			
	TYPE & TEMPER			
	H			
	HEAT TREAT. SPEC.			
	S-404 YELLOW IRIDITE			
	FINISH & SPEC. NO.			

MS-298 D