

IF IT IS FOUND DESIRABLE TO CHANGE ANY TOLERANCE OR OTHER DETAIL SPECIFIED ON THIS DRAWING NOTIFY THE PURCHASER PROMPTLY.
 MAXIMUM ALLOWABLE TOLERANCES HAVE BEEN DETERMINED AND DEVIATIONS WILL BE CAUSE FOR REJECTION. REMOVE ALL BURRS AND SHARP EDGES

HOLES	REQ'D.
A - 9/64 DIA.	4
B - 11/64 DIA.	7
C - 7/8 DIA.	7
D - 1/8 DIA.	1
E - 1 3/8 DIA.	1

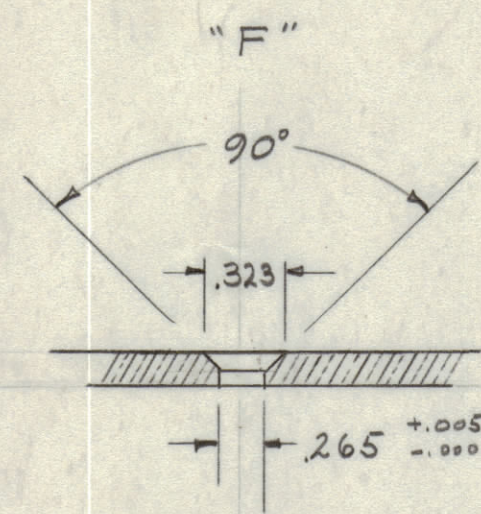

SM-107-3-4
5 REQ'D.

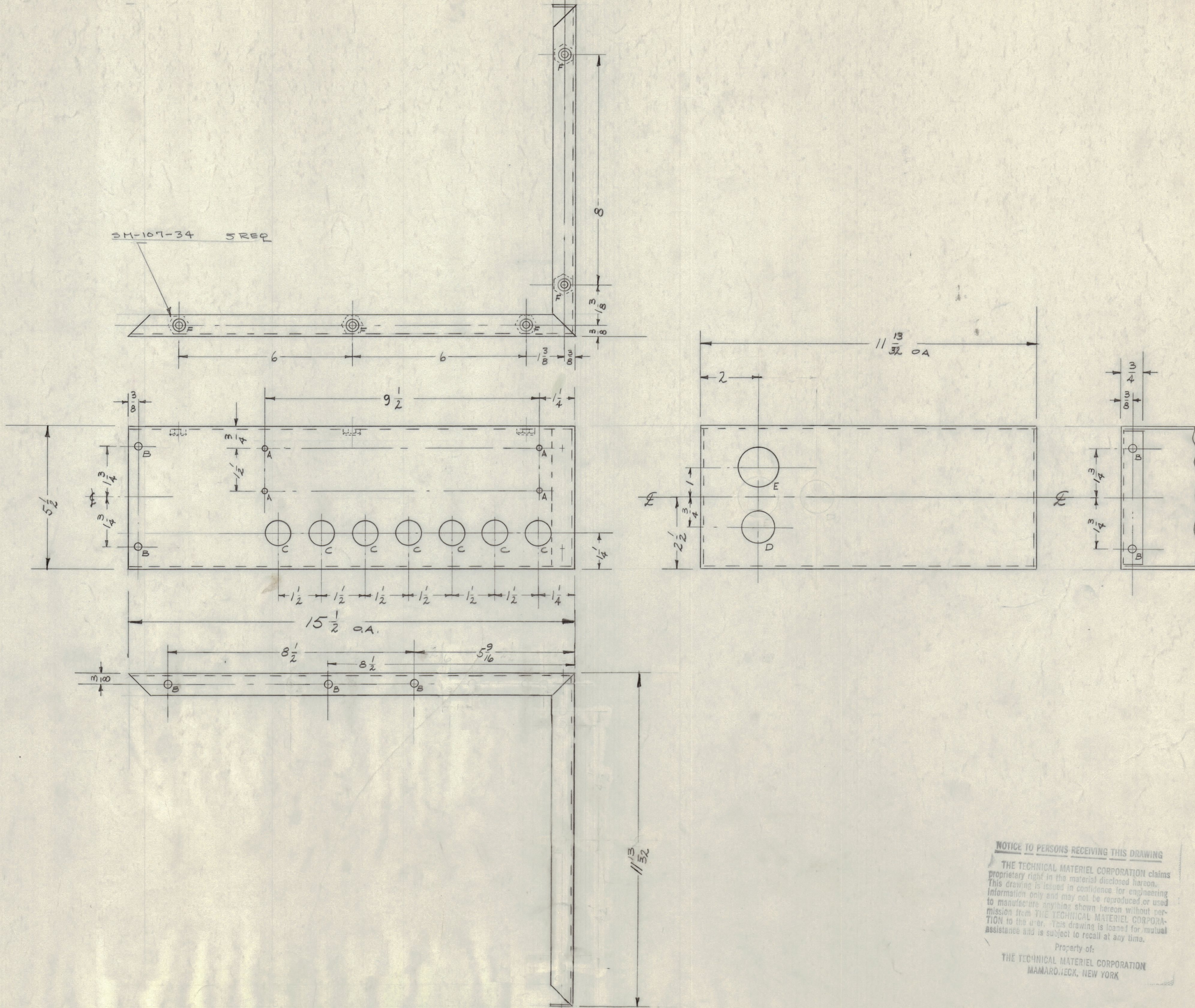
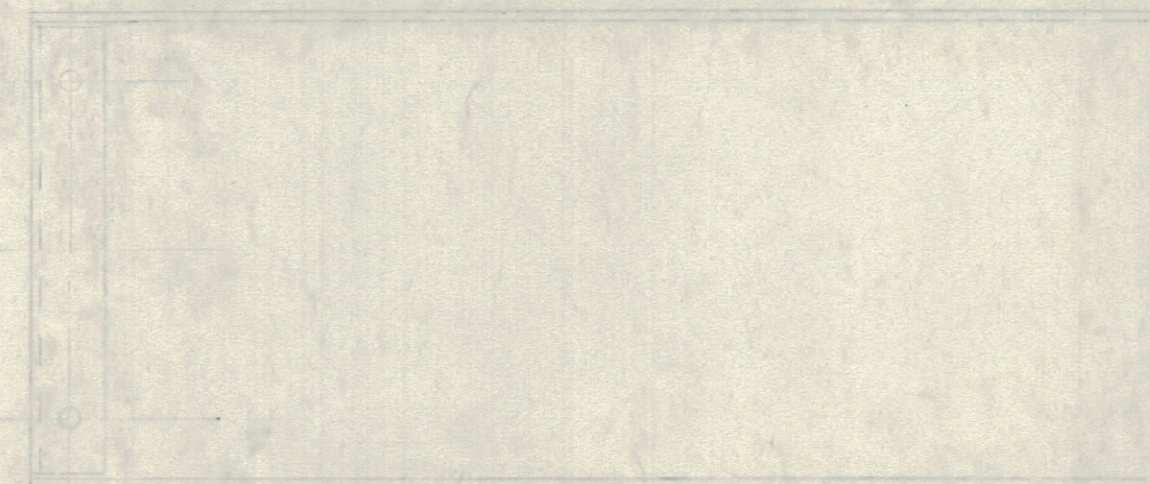

MS-1618

NOTICE TO PERSONS RECEIVING THIS DRAWING
 THE TECHNICAL MATERIEL CORPORATION claims proprietary right in the material disclosed herein. This drawing is issued in confidence for engineering information only and may not be reproduced or used to manufacture anything shown herein without permission from THE TECHNICAL MATERIEL CORPORATION to the user. This drawing is loaned for mutual assistance and is subject to recall at any time.
 Property of:
 THE TECHNICAL MATERIEL CORPORATION
 MAMARONECK, NEW YORK

ISSUE	ITEM	CHANGED FROM	DATE	CN. NO.	DRAFTS	CHECKER	ENG. APP.
TOLERANCES							
ALL OTHERS			SCALE:				
DEC. DIM. ±			DRILL PUNCH COMMERCIAL STOCK				
FRAC. DIM. ±			SIZES AND MANUFACTURERS				
ANGULAR DIM. ±			TOLERANCES ARE NOT INCLUDED.				

REQ. PER UNIT	MODEL	PROJECT NO.	ASSY. NO.	DATE
1	GPT-10K	Power Supply		2-26-59

REQ. ITEM	PART NO.	DESCRIPTION	SYMBOL
.081 THICK		STOCK SIZE	
ALUMINUM		WRAP AROUND, LINE FILTER	
5052-H32		WEIGHT PER PC.	GPT-10K
TYPE & TEMPER		108110	108110
HEAT TREAT. SPEC.		DRWN	ELEC. DES. APP. MECH. DES. APP.
5404 IRIDIUM		CHECKED	FINAL APPROVAL
FINISH & SPEC. NO.			MS-1618