

REQ. PER UNIT	USED ON		
	MODEL	ASS'Y. NO.	DATE
3	9PT-101K	AH-102344	2-18-59

MS-1596 A

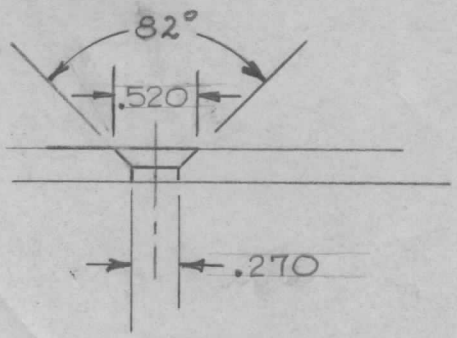

"B"  
1-REQ'D.

DRILL + C'SINK  
FOR 1/4-20

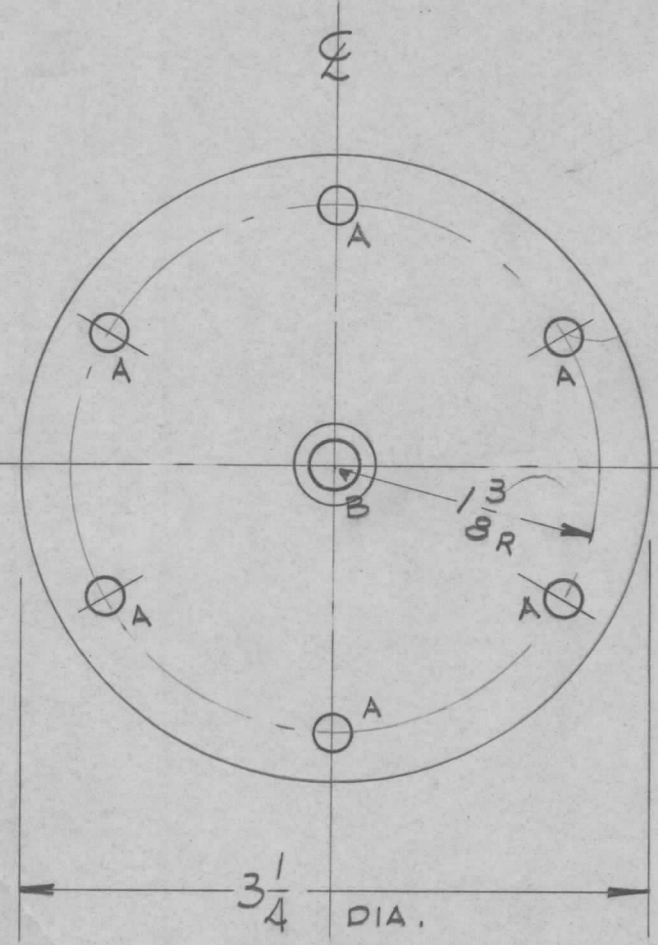

HOLES  
A - 3/16 DIA 60° APART  
REQ'D. 6

REMOVE SHARP  
EDGES

ISSUE	ITEM	CHANGED FROM	DATE	CH. NO.	DRAFTS	CHECKER	ENG. APP.	REQ. ITEM	PART NO.	DESCRIPTION	SYMBOL	
								1/8 THICK STOCK SIZE		THE TECHNICAL MATERIEL CORP. MAMARONECK, NEW YORK		
								ALUMINUM		CONDENSER TOP PLATE		
								MATERIAL				
								5052-H32		<del>TORILLO</del> file	APP	
								TYPE & TEMPER	HEAT TREAT. SPEC.	DRAWN	CHECKED	
								SILVER PLATE 10005			20	
								FINISH & SPEC. NO.		ELEC. DES. APP	MECH. DES. APP	
TOLERANCES			SCALE:									
DEC. DIM. ±			MAXIMUM ALLOWABLE TOLERANCES HAVE BEEN DETERMINED AND ANY DEVIATIONS WILL BE CAUSE FOR REJECTION. REMOVE ALL BURRS AND SHARP EDGES									
FRAC. DIM. ±												
ANGULAR DIM. ±												
1/64								MS-1596 <span style="border: 1px solid black; padding: 2px;">A</span>				