

IF IT IS FOUND DESIRABLE TO CHANGE ANY TOLERANCE OR OTHER DETAIL SPECIFIED ON THIS DRAWING NOTIFY THE PURCHASER PROMPTLY.
 MAXIMUM ALLOWABLE TOLERANCES HAVE BEEN DETERMINED AND DEVIATIONS WILL BE CAUSE FOR REJECTION. REMOVE ALL BURRS AND SHARP EDGES

NOTICE TO PERSONS RECEIVING THIS DRAWING

THE TECHNICAL MATERIEL CORPORATION claims proprietary right in the material disclosed herein. This drawing is issued in confidence for engineering information only and may not be reproduced or used to manufacture anything shown hereon without permission from THE TECHNICAL MATERIEL CORPORATION to the user. This drawing is loaned for mutual assistance and is subject to recall at any time.

Property of:
 THE TECHNICAL MATERIEL CORPORATION
 MAMARONECK, NEW YORK

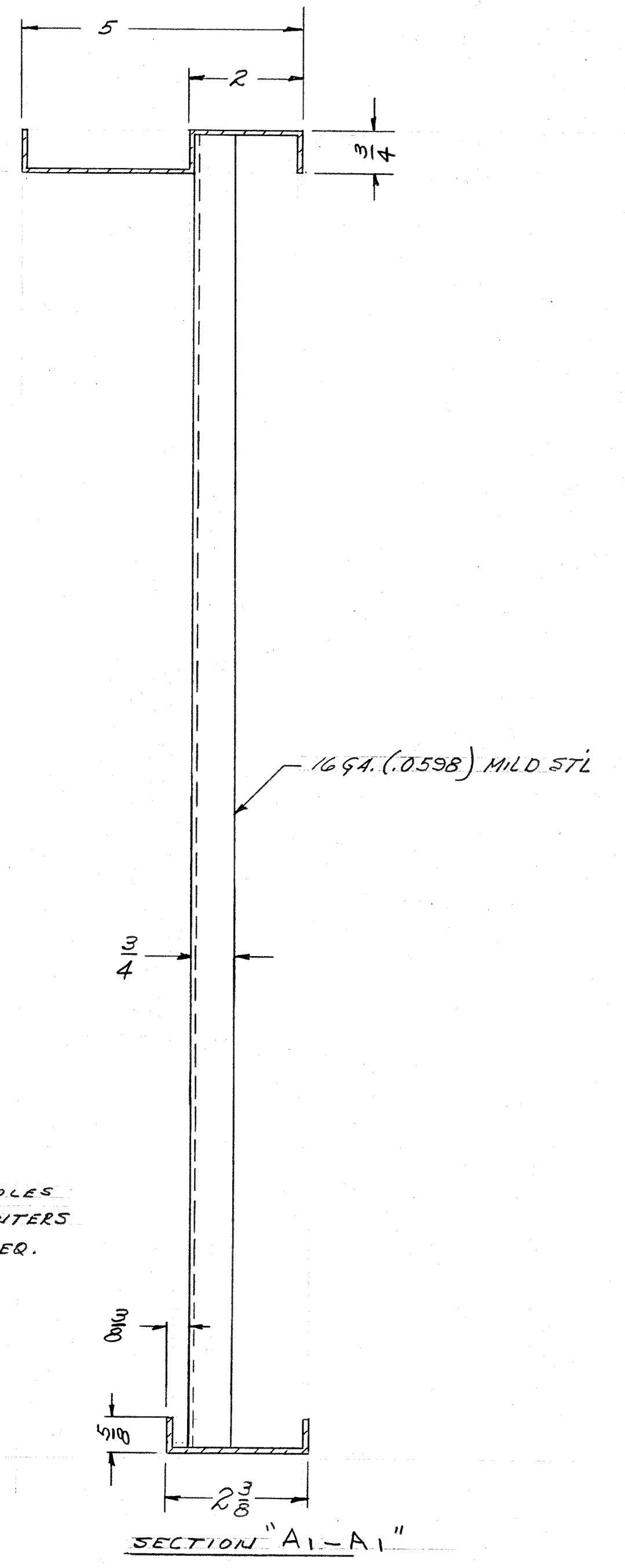
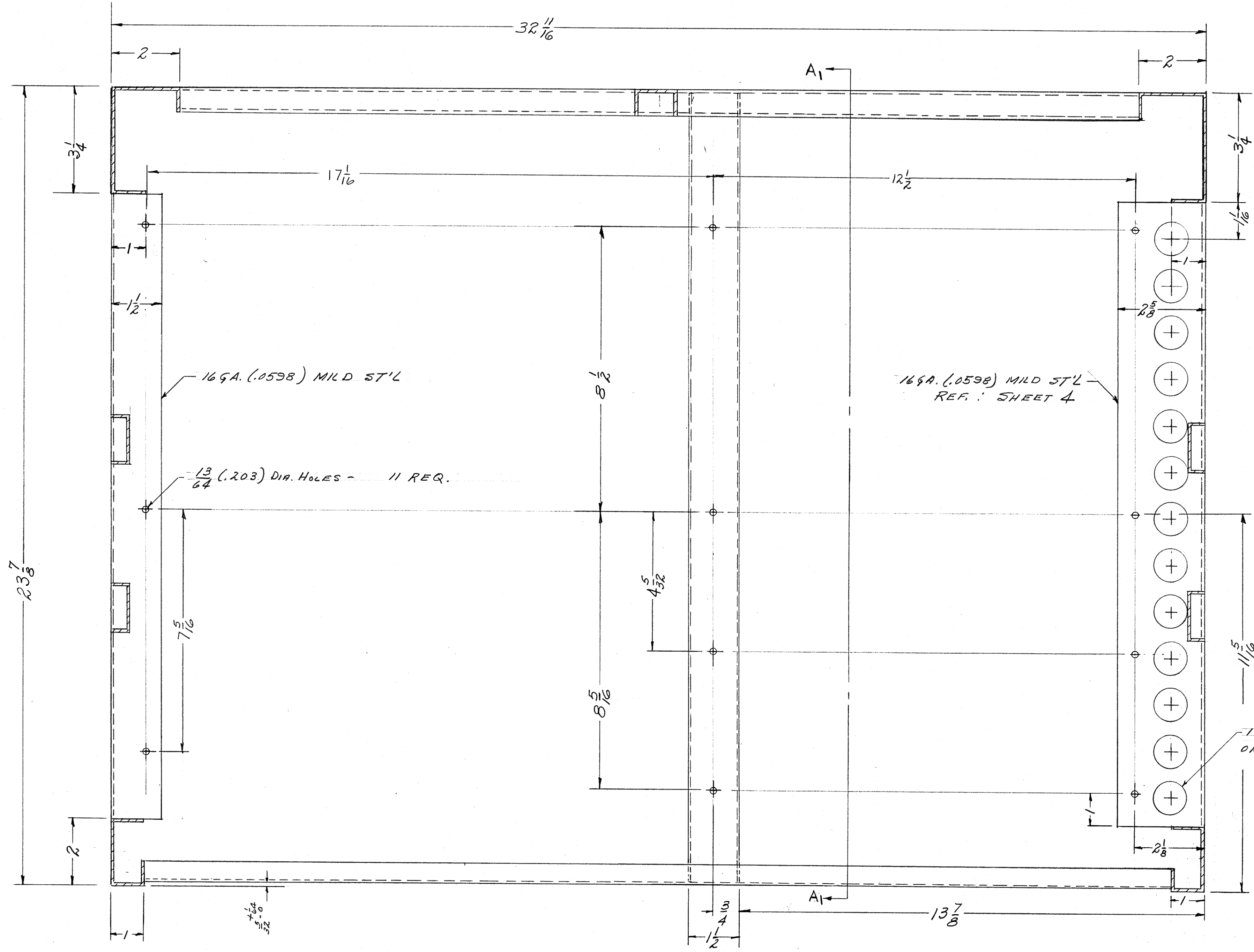

FRONT

SECTION "A1-A1"

NOTE: MATERIAL 12 GA. (.1046) MILD STEEL UNLESS NOTED OTHERWISE

K	SEE SHEET 7	12/22/2010	GE	2	2		
J	SEE SHEET 1 OF 2	3-9-66	15893	WHJ	2/2		
H	SEE SHEET 11 OF 12	4-15-63	8242	RE	2/2		
G	SEE SHEET 12 OF 1	11-15-66	5807	RL	2/2		
F	Revision Letter Clarified	1/31/61	4019	DM	2/2		
E	DIHEUS CLARIFIED	7/18/62	244	WSE	2/2		
D	5/2 WAS 1/8	12/6/62	556	WSE	2/2		
A	REDIMENSIONED	1/12/63		WSE	2/2		
ISSUE	ITEM	CHANGED FROM	DATE	CN. NO.	DRAFTS	CHECKER	ENG. APP.

TOLERANCES: 6" = 1/10"
 ALL DEC. DIM. ± } SEE 5-396
 OTHERS ANGULAR DIM. ± }
 DRILL PUNCH COMMERCIAL STOCK SIZES AND MANUFACTURERS TOLERANCES ARE NOT INCLUDED.

1	CAB-7	PROJECT NO.	10-13-58
REQ PER UNIT	MODEL	ASSY. NO.	DATE
USED ON			

REQ. ITEM	PART NO.	DESCRIPTION	SYMBOL
SEE 5-396		THE TECHNICAL MATERIEL CORP. MAMARONECK, NEW YORK	
STOCK SIZE		CABINET	
MATERIAL	WEIGHT PER PC.	CROSS SECTION A-A	
TYPE & TEMPER		10-13-58	2/2
HEAT TREAT. SPEC.		DRAWN	ELEC. DES. APP. MECH. DES. APP.
FINISH & SPEC. NO.		CHECKED	FINAL APPROVAL
		SHEET 9 OF 12	MS-1360 K

MS-1360 K