

REQ. PER UNIT	USED ON		
	MODEL	ASS'Y. NO.	DATE
1	ATS-50TU		12-17-57
1	ATS-70TU		12-17-57

MS-1173 B

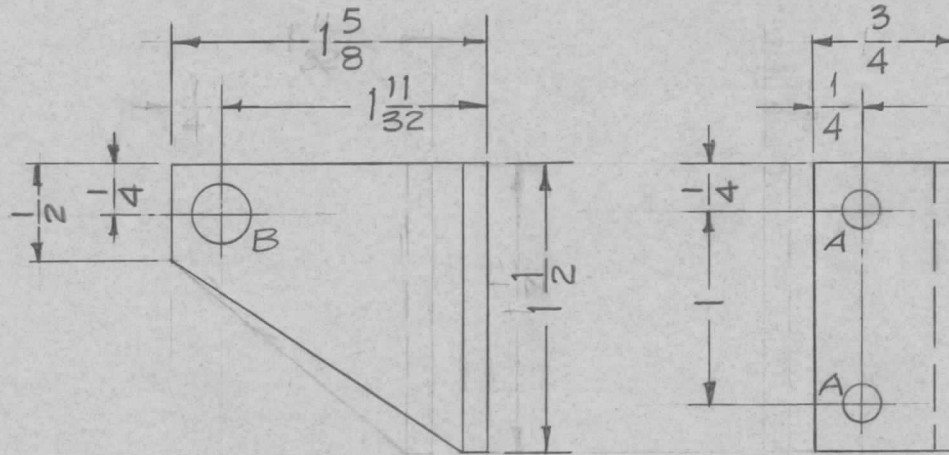

A - 13/64 (.203) D. - 2 Req.

B - 5/16 (.312) D. - 1 Req. (for BB-117-6)

ISSUE	ITEM	CHANGED FROM	DATE	CH. NO.	DRAFTS	CHECKER	ENG. APP.	REQ. ITEM	PART NO.	DESCRIPTION	SYMBOL		
								1 x 122 x 1/8 Thk.		THE TECHNICAL MATERIEL CORP. MAMARONECK, NEW YORK			
B	2	On lip, 1/4" Dim was 1/2"	10/24/60	3251	J.C.B.	Jde	Jde	STOCK SIZE		SUPPORT, POTENTIOMETER SHAFT			
	1	On lip, 3/4" Dim. was 1"						Aluminum					
A	1	S404 - IRIDITE WAS S101 - CAUSTIC DIP	12-8 59	1001	P		EMN	MATERIAL					
TOLERANCES			SCALE: FULL					6063-T5	A	12-17-57	Jde	ah	
DEC. DIM. ±			MAXIMUM ALLOWABLE TOLERANCES HAVE BEEN DETERMINED AND ANY DEVIATIONS WILL BE CAUSE FOR REJECTION. REMOVE ALL BURRS AND SHARP EDGES					TYPE & TEMPER	HEAT TREAT. SPEC.	DRAWN	CHECKED	FINAL APPROVAL	
FRAC. DIM. ± 1/64								S404-IRIDITE		Jde	Jde	MS-1173	B
ANGULAR DIM. ±								FINISH & SPEC. NO.				ELEC. DES. APP.	MECH. DES. APP.