

IF IT IS FOUND DESIRABLE TO CHANGE ANY TOLERANCE OR OTHER DETAIL SPECIFIED ON THIS DRAWING NOTIFY THE PURCHASER PROMPTLY.

MAXIMUM ALLOWABLE TOLERANCES HAVE BEEN DETERMINED AND DEVIATIONS WILL BE CAUSE FOR REJECTION. REMOVE ALL BURRS AND SHARP EDGES

NOTICE TO PERSONS RECEIVING THIS DRAWING

THE TECHNICAL MATERIEL CORPORATION claims proprietary right in the material disclosed herein. This drawing is issued in confidence for engineering information only and may not be reproduced or used to manufacture anything shown hereon without permission from THE TECHNICAL MATERIEL CORPORATION to the user. This drawing is loaned for mutual assistance and is subject to recall at any time.

Property of:  
THE TECHNICAL MATERIEL CORPORATION  
MAMARONECK, NEW YORK

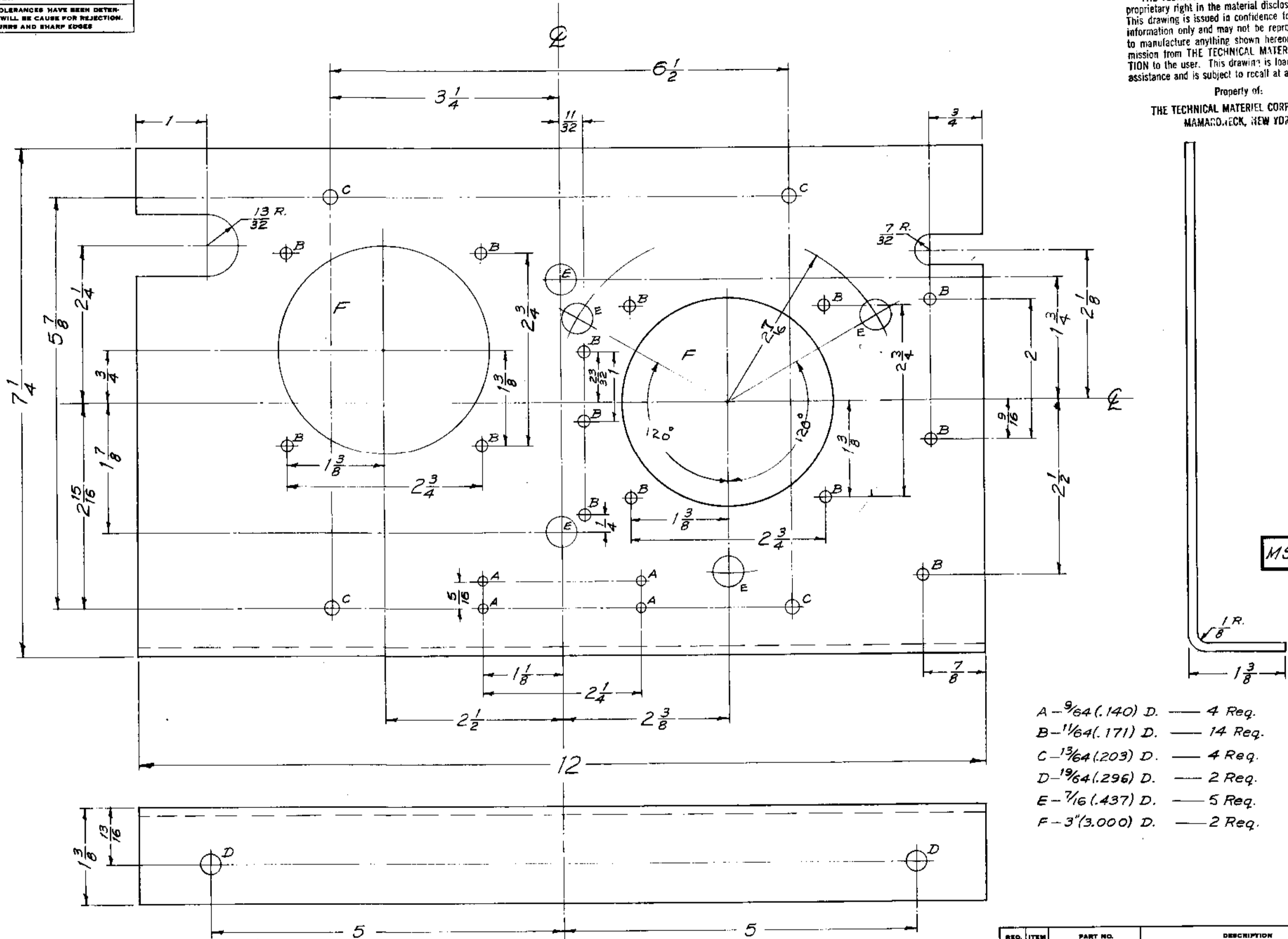

MS-1163 E

- A - 9/64 (.140) D. — 4 Req.
- B - 1 1/64 (.171) D. — 14 Req.
- C - 1 3/64 (.203) D. — 4 Req.
- D - 1 9/64 (.296) D. — 2 Req.
- E - 7/16 (.437) D. — 5 Req.
- F - 3" (3.000) D. — 2 Req.

ISSUE	ITEM	CHANGED FROM	DATE	CN. NO.	DRAFTS	CHECKER	ENG. APP.
E	1	3404 MASS 101	1-23-58	1001	P		
D	1	1 1/4 WAS 1 1/2	1-23-58	4			
C	1	3 "E" HOLES ADDED	1-23-58	3			
B	1	1 1/2 WAS 1 3/4	1-23-58	2			
A	2	13 R/32 WAS 7/16 W. (SCREW HOLE)	1-23-58	1			
	1	5/16 WAS 7/8 (STRIP HOLE) (Error)	1-23-58	1			

ALL OTHERS	DEC. DIM. ±	FRAC. DIM. ±	ANGULAR DIM. ±	DRILL, PUNCH, COMMERCIAL STOCK SIZES AND MANUFACTURERS TOLERANCES ARE NOT INCLUDED.
		± 1/64		

REQ. PER UNIT	MODEL	PROJECT NO.	ASSY. NO.	DATE
1	ATS-70TU			1-23-58
1	ATS-50TU			1-23-58

REQ.	ITEM	PART NO.	DESCRIPTION	SYMBOL
			1/8 THK.	
			STOCK SIZE	
			Aluminum	
			MATERIAL	
			5052-H32	
			TYPE & TEMPER	
			NEAT TREAT. SPEC.	
			FINISH & SPEC. NO.	

THE TECHNICAL MATERIEL CORP.  
MAMARONECK, NEW YORK  
PLATE, MOUNTING, FRONT  
1-23-58  
MS-1163