

IF IT IS FOUND DESIRABLE TO CHANGE ANY TOLERANCE OR OTHER DETAIL SPECIFIED ON THIS DRAWING NOTIFY THE PURCHASER PROMPTLY.

MAXIMUM ALLOWABLE TOLERANCES HAVE BEEN DETERMINED AND DEVIATIONS WILL BE CAUSE FOR REJECTION. REMOVE ALL BURRS AND SHARP EDGES

RELEASED

MS-168 A

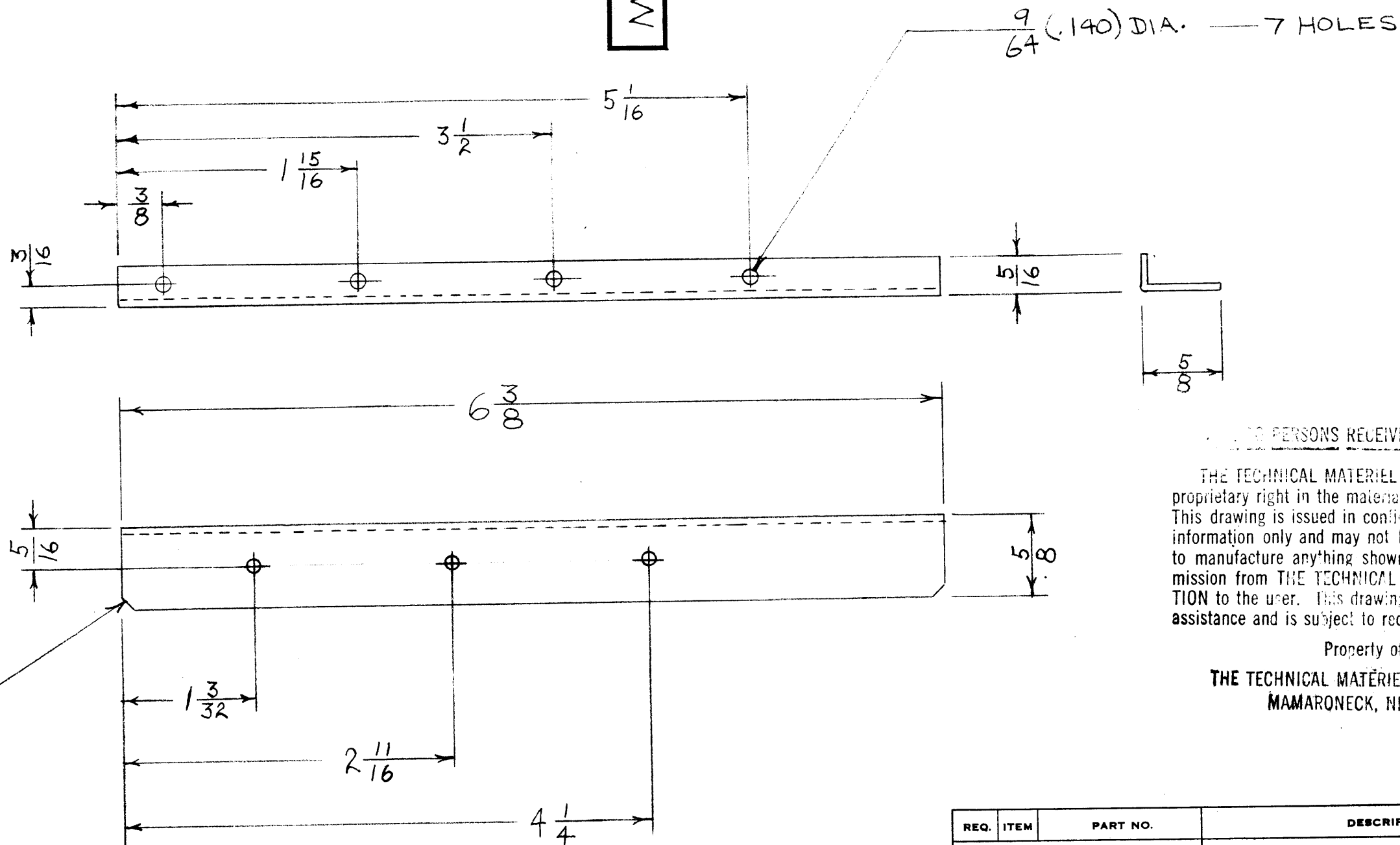

PERSONS RECEIVING THIS DRAWING

THE TECHNICAL MATERIEL CORPORATION claims proprietary right in the material disclosed hereon. This drawing is issued in confidence for engineering information only and may not be reproduced or used to manufacture anything shown hereon without permission from THE TECHNICAL MATERIEL CORPORATION to the user. This drawing is loaned for mutual assistance and is subject to recall at any time.

Property of:  
THE TECHNICAL MATERIEL CORPORATION  
MAMARONECK, NEW YORK

NICK CORNERS  
APPROX. 1/8

A	1	S-404 WAS S-101	12/1/52	1001	EMN
ISSUE	ITEM	CHANGED FROM	DATE	CN. NO.	ENG. APP.
TOLERANCES		SCALE:			
ALL OTHERS		DRILL, PUNCH, COMMERCIAL STOCK SIZES AND MANUFACTURERS TOLERANCES ARE NOT INCLUDED.			
DEC. DIM. ±					
FRAC. DIM. ± 1/64					
ANGULAR DIM. ±					

FFRD-8	104	A-229	12-12-52
FFRD-7	104	A-229	12-12-52
FFRD-6	104	A-229	12-12-52
FFRD-5	104	A-229	12-12-52
MODEL	PROJECT NO.	ASS'Y. NO.	DATE
USED ON			

REQ. ITEM	PART NO.	DESCRIPTION	SYMBOL
	.040	THE TECHNICAL MATERIEL CORP.	
	STOCK SIZE	MAMARONECK, NEW YORK	
	ALUM.	BRACKET	
	MATERIAL		
	WEIGHT PER PC.		
	52S-H32		
	TYPE & TEMPER		
		WDC 12-12	
	HEAT TREAT. SPEC.		
	S-404 YELLOW IRIDITE	ARB	
	FINISH & SPEC. NO.	CHECKED	FINAL APPROVAL
			MS-168 A