

IF IT IS FOUND DESIRABLE TO CHANGE ANY TOLERANCE OR OTHER DETAIL SPECIFIED ON THIS DRAWING NOTIFY THE PURCHASER PROMPTLY.

MS-107 

MAXIMUM ALLOWABLE TOLERANCES HAVE BEEN DETERMINED AND DEVIATIONS WILL BE CAUSE FOR REJECTION. REMOVE ALL BURRS AND SHARP EDGES

USED ON

MODEL	PROJECT NO.	ASS'Y. NO.	DATE
ES85/U	135	A-113	7-23-57
TCA-85/12	154	A-133	9-4-57

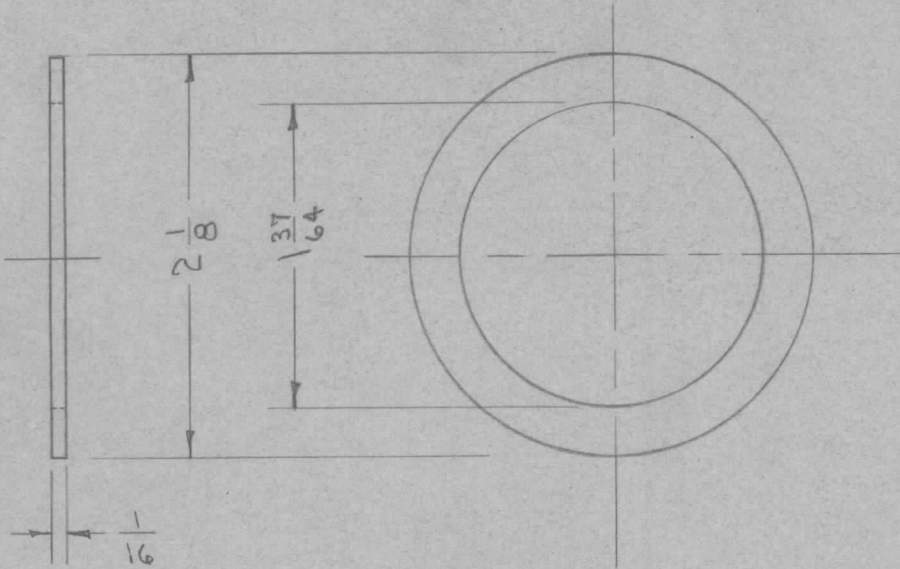

REQ.	ITEM	PART NO.	DESCRIPTION	SYMBOL
		$\frac{1}{16}$ (.062) THK.	THE TECHNICAL MATERIEL CORP.	
		STOCK SIZE	MAMARONECK, NEW YORK	
		LEAD	SEAL WASHER	
		MATERIAL	WEIGHT PER PC.	
		TYPE & TEMPER	C.D.D. 1-23-53	
			DRAWN	ELEC. DES. APP. MECH. DES. APP.
		HEAT TREAT. SPEC.	MD 1-28-53	
			CHECKED	FINAL APPROVAL
		FINISH & SPEC. NO.		

		REDRAWN NO CHANGE.	1-23-53		C.D.D.	MD	0976
ISSUE	ITEM	CHANGED FROM	DATE	CN. NO.	DRAFTS	CHECKER	ENG. APP.
TOLERANCES		SCALE					
ALL OTHERS	DEC. DIM. $\pm$	DRILL, PUNCH, COMMERCIAL STOCK SIZES AND MANUFACTURERS TOLERANCES ARE NOT INCLUDED.					
	FRAC. DIM. $\pm \frac{1}{64}$						
	ANGULAR DIM. $\pm$						

MS-107 