

MS-1053 B

NOTICE TO PERSONS RECEIVING THIS DRAWING

THE TECHNICAL MATERIEL CORPORATION claims proprietary right in the material disclosed hereon. This drawing is issued in confidence for engineering information only and may not be reproduced or used to manufacture anything shown hereon without permission from THE TECHNICAL MATERIEL CORPORATION to the user. This drawing is loaned for mutual assistance and is subject to recall at any time.

Property of:
THE TECHNICAL MATERIEL CORPORATION
MAMARONECK, NEW YORK

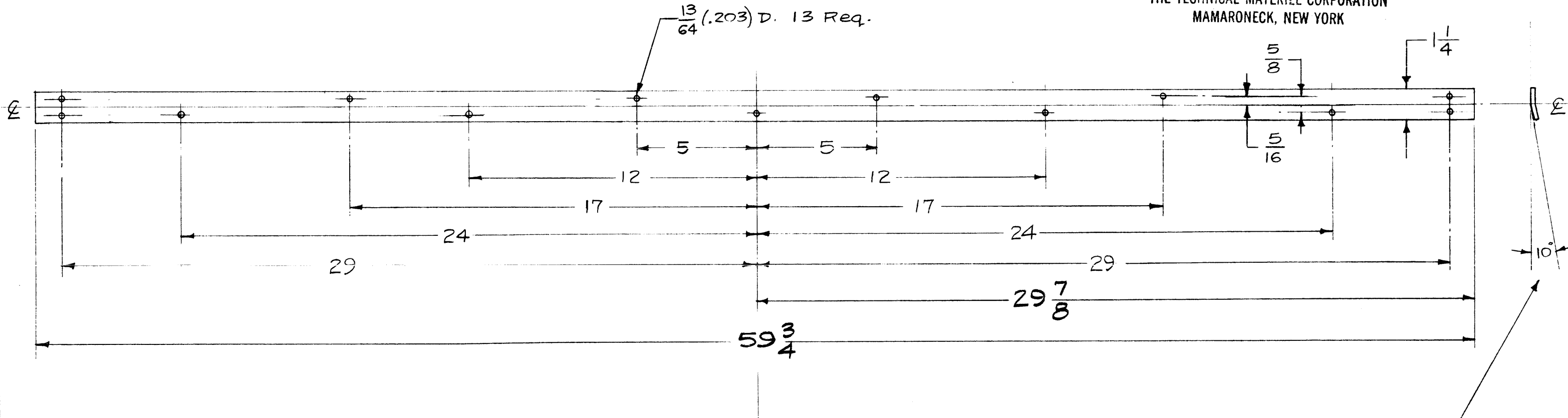

NOTE - BREAK 10° AFTER DRILLING HOLES

FINISH:
S 404 IRIDITE
S 114 ZINC CHROMATE PRIMER
S 115 GRAY ENAMEL

ISSUE	ITEM	CHANGED FROM	DATE	CH. NO.	DRAFTS	CHECKER	ENG. APP.
B	1	S 404 (IRIDITE) ADDED	6/9/59	-	JA		
A	1	29 7/8 WAS 30 (ILL) 59 3/4 WAS 60 (O/A)	2/1/59	732	16	JAN 59	

TOLERANCES
DEC. DIM. ±
FRAC. DIM. ±
ANGULAR DIM. ±

SCALE: 1/4

MAXIMUM ALLOWABLE TOLERANCES HAVE BEEN DETERMINED AND ANY DEVIATIONS WILL BE CAUSE FOR REJECTION. REMOVE ALL BURRS AND SHARP EDGES

REQ. PER UNIT	MODEL	PROJECT NO.	ASS'Y. NO.	DATE
1	TER-5000-600		A-1431 (B)	

USED ON

REQ. ITEM	PART NO.	DESCRIPTION	SYMBOL
.064 THK.		THE TECHNICAL MATERIEL CORP. MAMARONECK, NEW YORK	
STOCK SIZE		MOLDING, CENTER, REAR (TER-5000)	
ALUMINUM			
MATERIAL			
5052-H32		164-30-57	
TYPE & TEMPER	HEAT TREAT. SPEC.	DRAWN	CHECKED
SEE NOTE			
FINISH & SPEC. NO.		ELEC. DES. APP.	MECH. DES. APP.

MS-1053 B