

IF IT IS FOUND DESIRABLE TO CHANGE ANY TOLERANCE OR OTHER DETAIL SPECIFIED ON THIS DRAWING NOTIFY THE PURCHASER PROMPTLY.
 MAXIMUM ALLOWABLE TOLERANCES HAVE BEEN DETERMINED AND DEVIATIONS WILL BE CAUSE FOR REJECTION. REMOVE ALL BURRS AND SHARP EDGES

NOTICE TO PERSONS RECEIVING THIS DRAWING
 THE TECHNICAL MATERIEL CORPORATION claims proprietary right in the material disclosed hereon. This drawing is issued in confidence for engineering information only and may not be reproduced or used to manufacture anything shown hereon without permission from THE TECHNICAL MATERIEL CORPORATION to the user. This drawing is loaned for mutual assistance and is subject to recall at any time.
 Property of:
 THE TECHNICAL MATERIEL CORPORATION
 MAMARONECK, NEW YORK

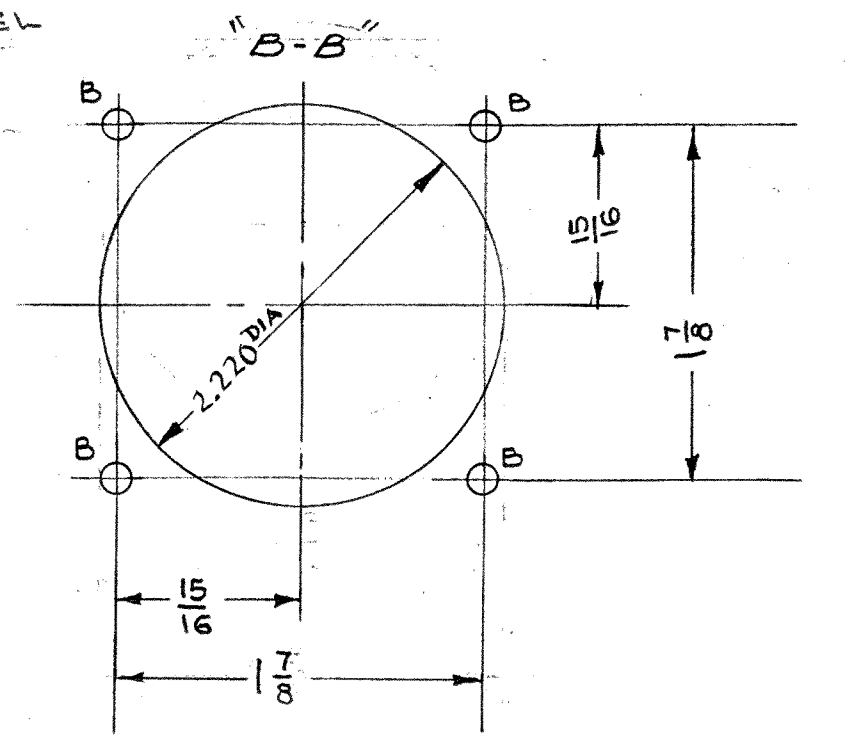

	"H" Hole	"C" Hole	"S" Hole
DIM.	#4 F.H.S	#8 F.H.S.	#6 F.H.S
X	*31 (.120)	*18 (.169)	*27 (.144)
Y	.230	.337	.284

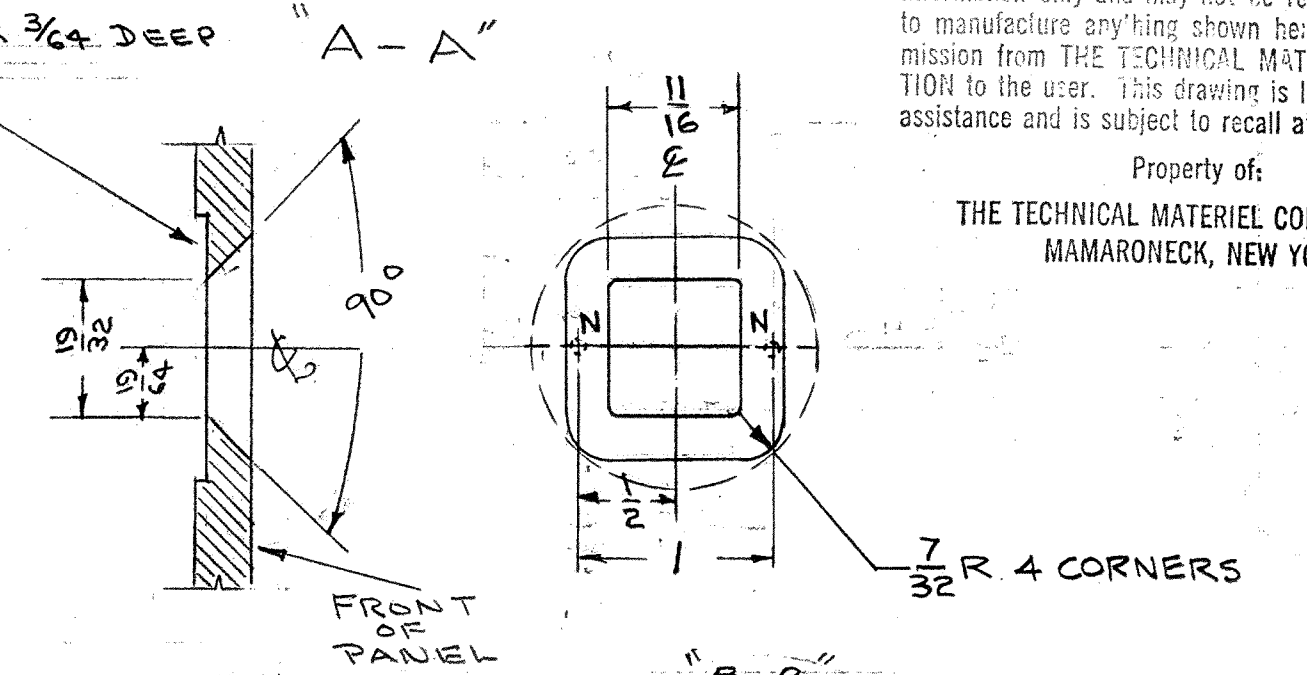
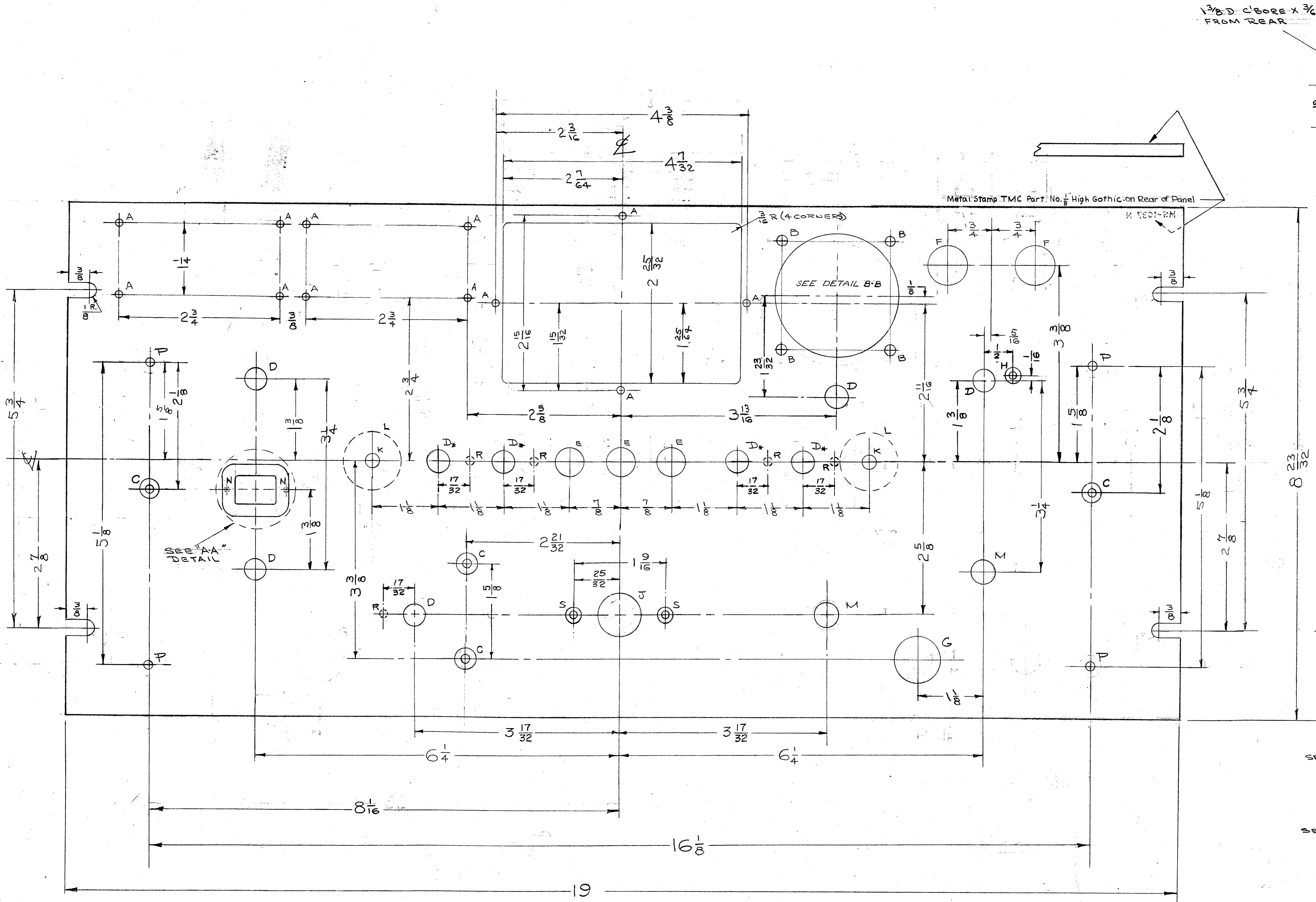
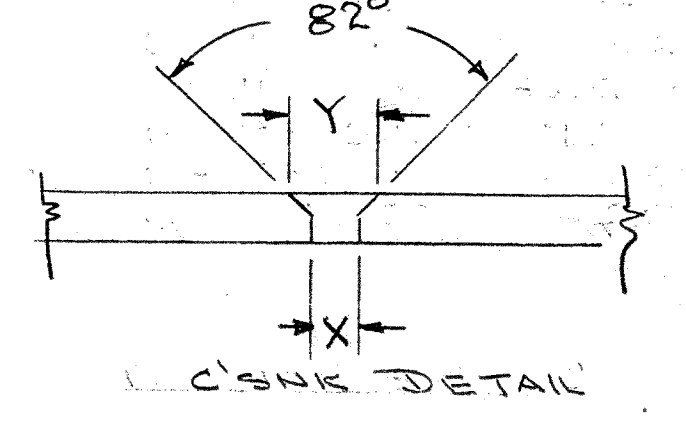

- A - #48 DRILL (.076) - 12 HOLES
- B - 3/16 D " " 4 " "
- SEE DETAIL C - DRILL & C'SNK FOR 8-32 F.H.S. 4 " "
- D - 3/8 D " " 9 " "
- E - 1/2 D " " 3 " "
- F - 11/16 D " " 2 " "
- G - 13/16 D " " 1 " "
- SEE DETAIL H - DRILL & C'SNK FOR 4-40 F.H.S. 1 " "
- J - 1.000 D. " " 1 " "
- K - 1/4 D " " 2 " "
- L - 1" D. C'BORE, 1/8 DEEP FROM REAR OF PANEL 2 REQ.
- M - 1/32 D " " 2 REQ.
- N - No 55 DRILL x 1/4" DEEP FROM REAR AFTER C'BORE 2 REQ.
- P - SEE CHART " " 4 REQ.
- R - 9/64 D. x 1/8 Deep From Rear 5 REQ.
- SEE DETAIL - S - DRILL & C'SNK FOR 6-32 F.H.S. 2 REQ.

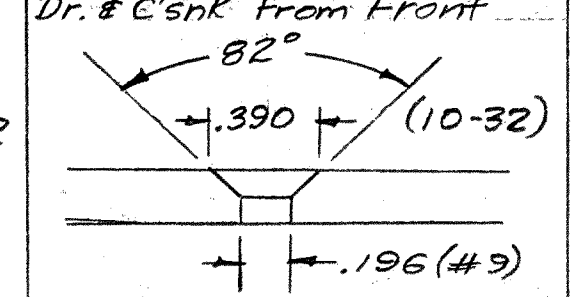
TMC NO.	"P" HOLE	USE
MS-1037-1	1/4 D. AS SHOWN	RACK MOUNTING
MS-1037-2	Dr. & C'snk From Front 	CABINET MOUNTING

NOTE: FINISH
 S-404 - YEL. IRIDITE
 S-114 - ZINC CH OXIDE PRIMER
 S-115 - SMOOTH GREY ENAMEL
 OR
 PRIME & PAINT ACCORDING TO CUSTOMER'S SPECIFICATIONS

ISSUE	ITEM	CHANGED FROM	DATE	CN. NO.	DRAFTS	CHECKER	ENG. APP.
R	1	DELE. "H" HOLES - (9/64) 2 EA.	1-24-46	15590	HLA	WJS	WJS
P	1	DETAIL OF 2.220 DIA WAS 2.214	2-16-47	13489	WJS	WJS	WJS
N	2	DETAIL AND CLARIFIED	5-21-50	30022	WJS	WJS	WJS
N	4	PART NO. STAMPING NOTE CORRECTED	5-21-50	30022	WJS	WJS	WJS

REQ. PER UNIT	MODEL	PROJECT NO.	ASSY. NO.	DATE
1	SBE-3	AO-101		11-25-59
1	SBE-2	A-1516		5-2-58
1	SBE-1	380		4-13-57

REQ. ITEM	PART NO.	DESCRIPTION	SYMBOL
3/16 THK		THE TECHNICAL MATERIEL CORP. MAMARONECK, NEW YORK	
ALUMINUM		FRONT PANEL	
2624-T3		SBE-1	
TYPE & TEMPER		DATE: 4-15-57	WJS
HEAT TREAT. SPEC.		DRAWN: WJS	ELEC. DES. APP.: WJS
SEE NOTE		CHECKED: WJS	MECH. DES. APP.: WJS
FINISH & SPEC. NO.			FINAL APPROVAL: WJS

MS-1037 R