

REQ. PER UNIT	USED ON		
	MODEL	ASS'Y. NO.	DATE
2	SBE-2		5-5-58
1	SBE-3	AO-101	11-25-59

MP-112 A

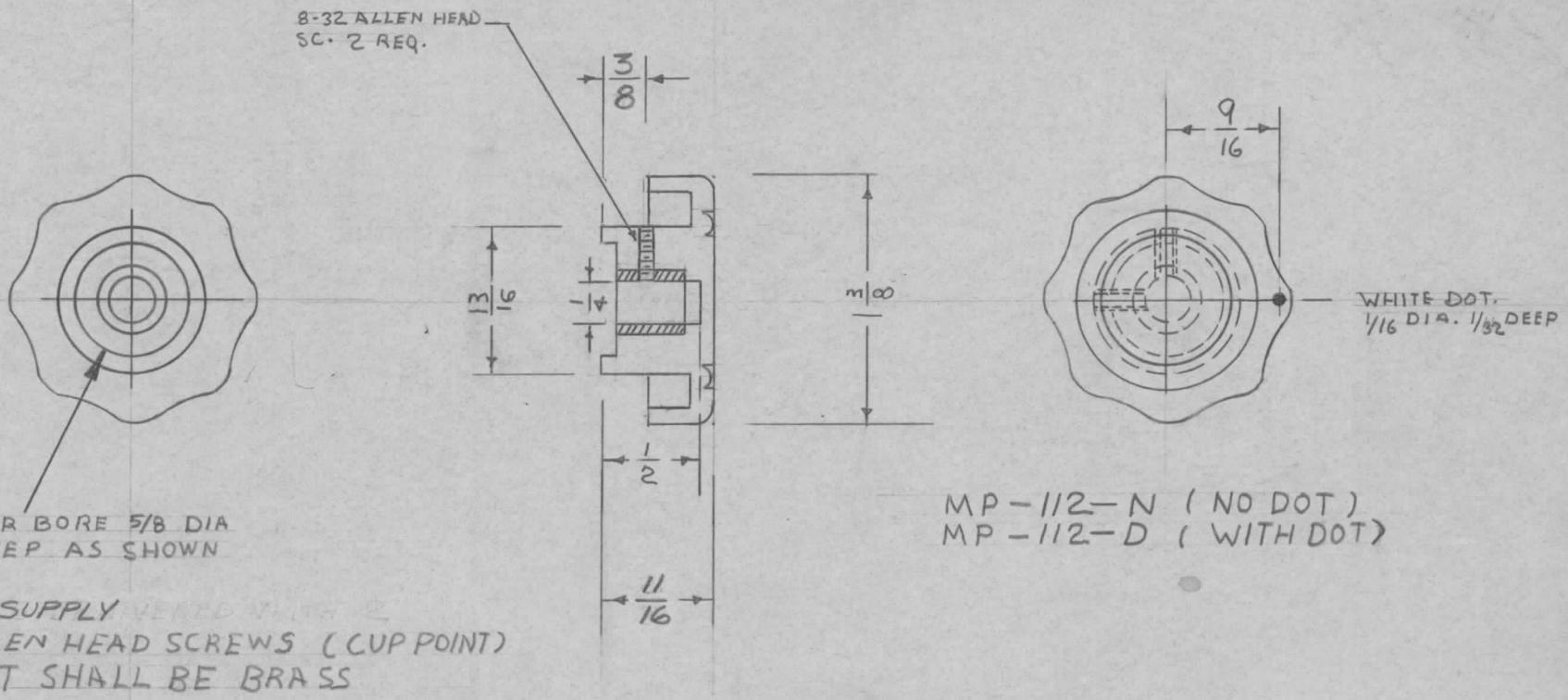

MP-112-N (NO DOT)  
MP-112-D (WITH DOT)

REF. HARRY DAVIES' STYLE #4101

ISSUE	ITEM	CHANGED FROM	DATE	CH. NO.	DRAFTS	CHECKER	ENG. APP.	REQ. ITEM	PART NO.	DESCRIPTION	SYMBOL		
								11	11	THE TECHNICAL MATERIEL CORP. MAMARONECK, NEW YORK			
								11	11	KNOB, INSTRUMENT			
A	-	3/8 WAS 1/4, 11/16 WAS 21/32, 5/64 WAS VB NOTE CHG	12/16/65	15359	A.V.V.	JOB	J						
TOLERANCES								SCALE:					
DEC. DIM. ± FRAC. DIM. ± ANGULAR DIM. ±								MAXIMUM ALLOWABLE TOLERANCES HAVE BEEN DETERMINED AND ANY DEVIATIONS WILL BE CAUSE FOR REJECTION. REMOVE ALL BURRS AND SHARP EDGES					
								TYPE & TEMPER	HEAT TREAT. SPEC.	DRAWN	CHECKED	FINAL APPROVAL	
								11	11	JOB	RWB	MP-112	A
								FINISH & SPEC. NO.		ELEC. DES. APP.	MECH. DES. APP.		