

IF IT IS FOUND DESIRABLE TO CHANGE ANY TOLERANCE OR OTHER DETAIL SPECIFIED ON THIS DRAWING NOTIFY THE PURCHASER PROMPTLY.

MAXIMUM ALLOWABLE TOLERANCES HAVE BEEN DETERMINED AND DEVIATIONS WILL BE CAUSE FOR REJECTION. REMOVE ALL BURRS AND SHARP EDGES

STANDARD DRAWING

MP-110

TO BE SUPPLIED BY MANUFACTURER TWO 10-32 X 3/8 ALLEN HEAD TYPE, CAD. PLATED, CUP POINT SET SCREWS INSTALLED

INSERT SHALL BE BRASS.

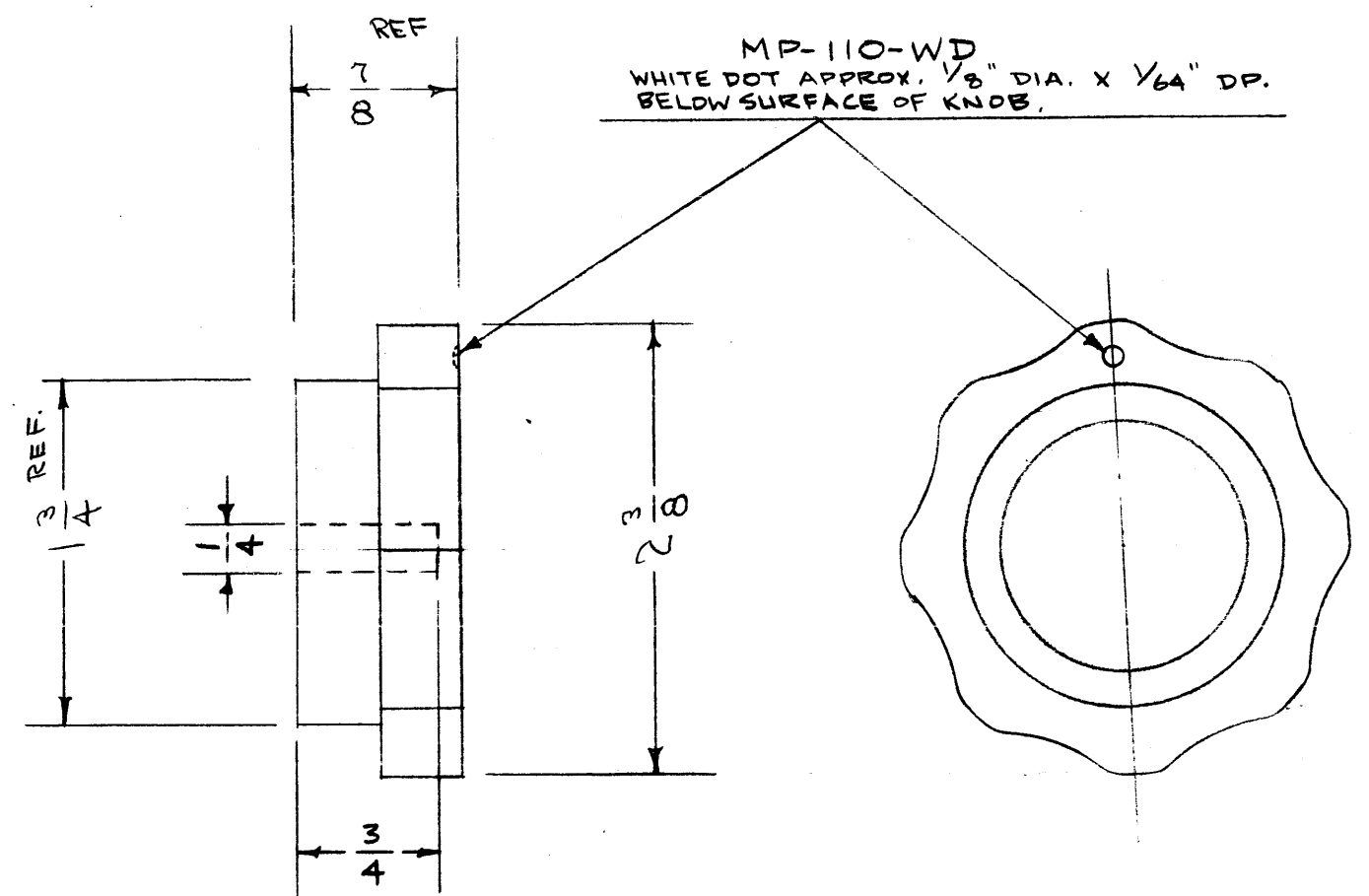
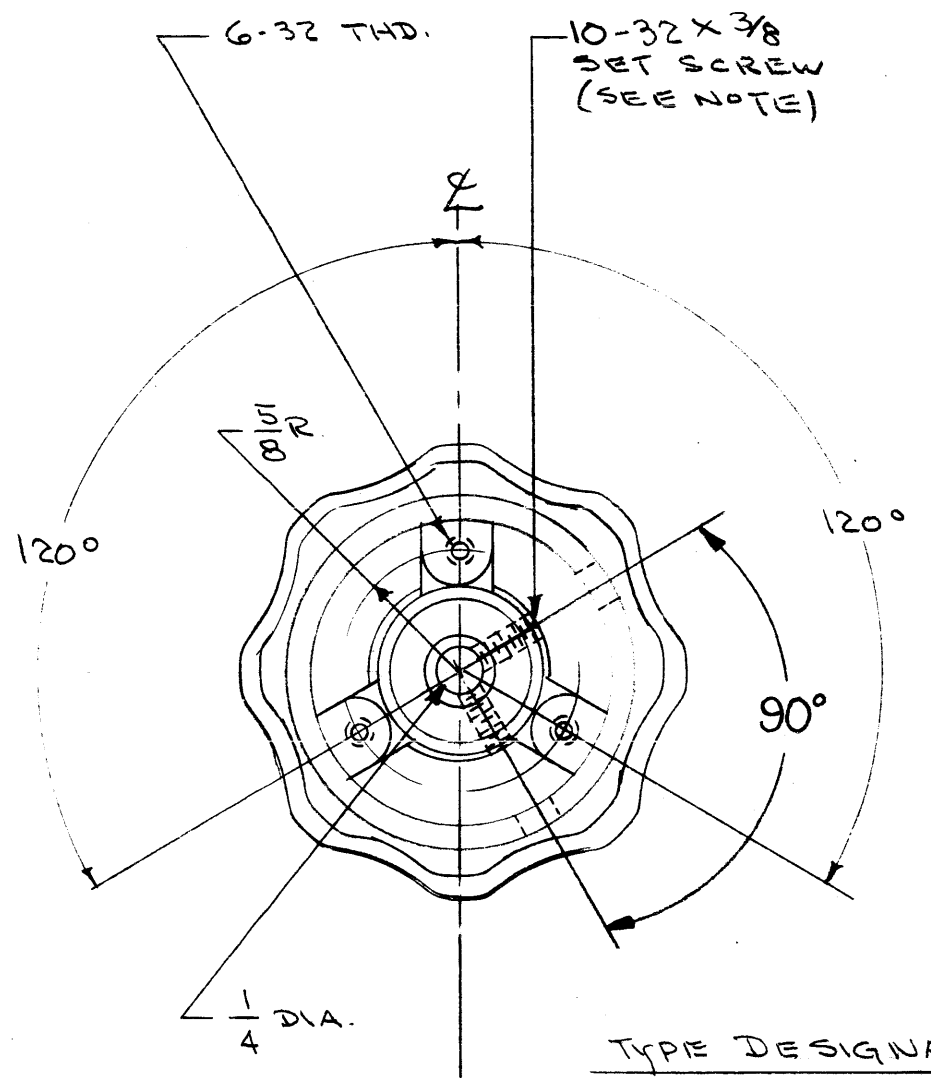

NOTICE TO PERSONS RECEIVING THIS DRAWING

THE TECHNICAL MATERIEL CORPORATION claims proprietary right in the material disclosed hereon. This drawing is issued in confidence for engineering information only and may not be reproduced or used to manufacture anything shown hereon without permission from THE TECHNICAL MATERIEL CORPORATION to the user. This drawing is loaned for mutual assistance and is subject to recall at any time.

Property of:
THE TECHNICAL MATERIEL CORPORATION
 MAMARONECK, NEW YORK

TYPE DESIGNATION TO BE IN FOLLOWING FORM

- MP-110 - NO DOT
- MP-110-WD - WITH WHITE DOT

STYLE NO 4103-AD (w/o DOT) {w/o SKIRT
 4103-CP (w/ DOT) {w/o SKIRT

ISSUE	ITEM	CHANGED FROM	DATE	CN. NO.	DRAFTS	CHECKER	ENG. APP.
C	1	Hole Dim 1/4 was 3/4 - 90° Dim Added	4-17-61	4691	RU	OCB	
B	1	SET SCREWS LENGTH ADDED	10/11/57	2	JAC	OCB	
A	1	SHAFT DIM. ADDED MP-110-WD 10-32 WAS 6-32	12/20/56	1	HS	OCB	

TOLERANCES		SCALE:
ALL OTHERS	DEC. DIM. ± FRAC. DIM. ± ANGULAR DIM. ±	DRILL, PUNCH, COMMERCIAL STOCK SIZES AND MANUFACTURERS TOLERANCES ARE NOT INCLUDED.

1	GPR(S) (R)	297	A-20-SS
REQ. PER UNIT	MODEL	PROJECT NO.	DATE
		ASSY. NO.	
		USED ON	

REF: HARRY DAVIS

REQ.	ITEM	PART NO.	DESCRIPTION	SYMBOL
			THE TECHNICAL MATERIEL CORP. MAMARONECK, NEW YORK	
			KNOB, INSTRUMENT TYPE	
			MATERIAL	WEIGHT PER PC.
			TYPE & TEMPER	LDD A-20-SS
			HEAT TREAT. SPEC.	
			DRAWN	ELEC. DES. APP.
			CHECKED	FINAL APPROVAL
				MP-110