

IF IT IS FOUND DESIRABLE TO CHANGE ANY TOLERANCE OR OTHER DETAIL SPECIFIED ON THIS DRAWING NOTIFY THE PURCHASER PROMPTLY.
 MAXIMUM ALLOWABLE TOLERANCES HAVE BEEN DETERMINED AND DEVIATIONS WILL BE CAUSE FOR REJECTION. REMOVE ALL BURRS AND SHARP EDGES

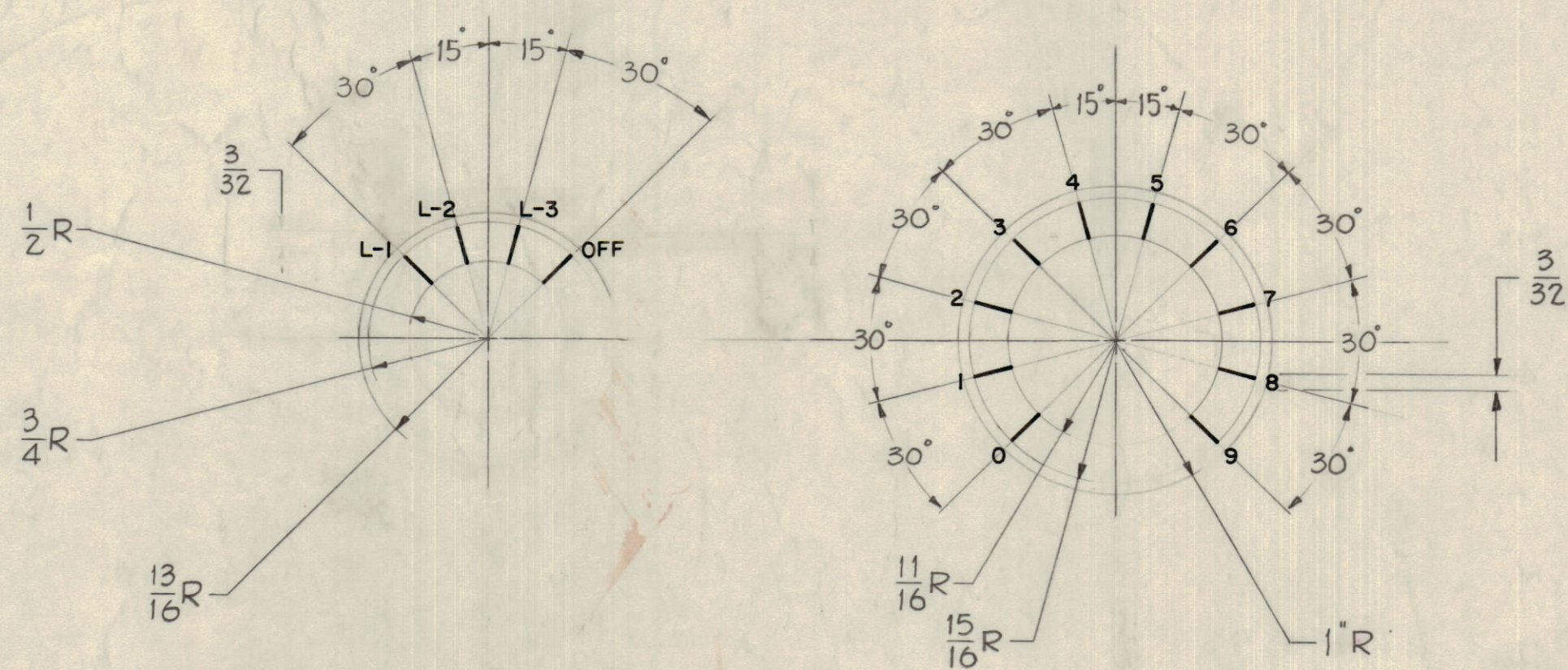

THIS DETAIL IS USED FOR KILOCYCLES & HUNDREDS OF CYCLES.

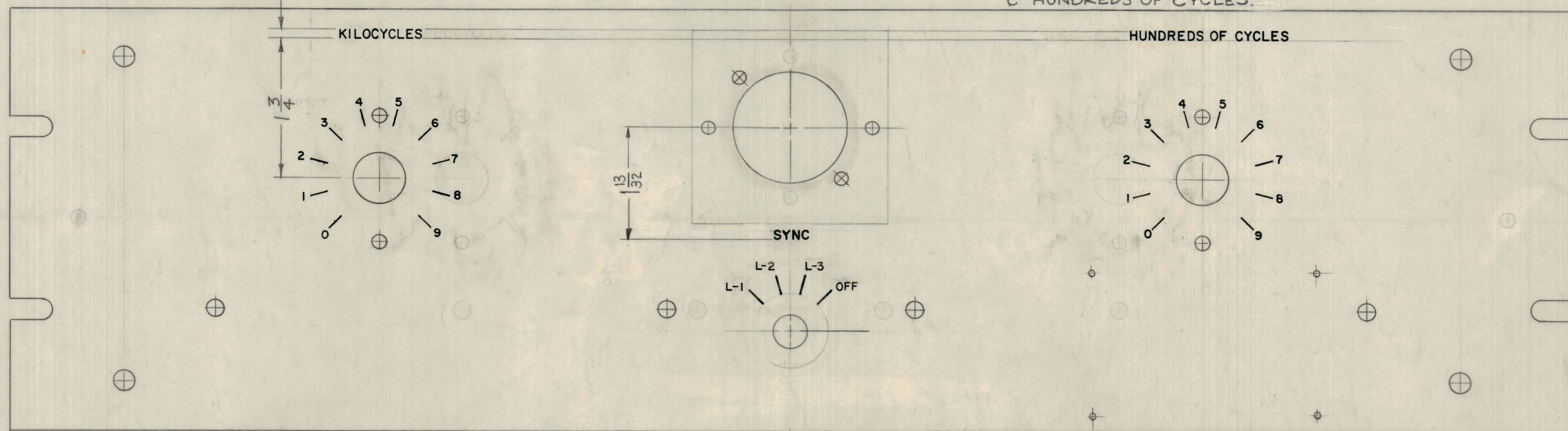

FRONT VIEW OF PANEL SHOWN (TO BE ENGRAVED) PER TMC SPEC- 5566

- NOTES ~ 1 ~ ALL LETTER GROUPS TO BE CENTERED ON HOLES.
 2 ~ ALL LINES TO BE WHITE FILLED.
 3 ~ ENGRAVING TO BE GOTHIC WHITE FILLED SIZES SHOWN ON CHART.

| HEIGHT OF LETTER | DEPTH OF STROKE | WIDTH OF STROKE |
|------------------|-----------------|-----------------|
| 3/32 | .010 | .015 |
| 1/8 | .010 | .020 |
| LINES | .010 | .015 |

NOTICE TO PERSONS RECEIVING THIS DRAWING

THE TECHNICAL MATERIEL CORPORATION claims proprietary right in the material disclosed herein. This drawing is issued in confidence for engineering information only and may not be reproduced or used to manufacture anything shown herein without permission from THE TECHNICAL MATERIEL CORPORATION to the user. This drawing is loaned for mutual assistance and is subject to recall at any time.

Property of:
 THE TECHNICAL MATERIEL CORPORATION
 MAMARONECK, NEW YORK

REF ~ FRONT PANEL, MACHINING ~ MS-2205

| REQ. ITEM | PART NO. | DESCRIPTION | SYMBOL |
|-----------|----------|--|---------------------------------|
| | | THE TECHNICAL MATERIEL CORP. MAMARONECK, NEW YORK | |
| | | STOCK SIZE | |
| | | FRONT PANEL ENGRAVING | |
| | | MATERIAL | WEIGHT PER PC. |
| | | | CLL-1 (FRONT) |
| | | TYPE & TEMPER | |
| | | DRAWN | ELEC. DES. APP. MECH. DES. APP. |
| | | CHECKED | FINAL APPROVAL |
| | | HEAT TREAT. SPEC. | |
| | | FINISH & SPEC. NO. | |

| | | | | | |
|--------------|-------|-------------|-----------|--------|------|
| 1 | CLL-1 | PROJECT NO. | ASSY. NO. | 2-2-60 | DATE |
| REQ PER UNIT | MODEL | USED ON | | | |

| | | | | | | |
|------------|---|--|------|---------|--------|---------|
| A | Sheet No 2 Added | 4-8-61 | 4598 | RU | | |
| ISSUE | ITEM | CHANGED FROM | DATE | CN. NO. | DRAFTS | CHECKER |
| TOLERANCES | | SCALE: | | | | |
| ALL OTHERS | DEC. DIM. ± FRAC. DIM. ± ANGULAR DIM. ± | DRILL PUNCH, COMMERCIAL STOCK SIZES AND MANUFACTURERS TOLERANCES ARE NOT INCLUDED. | | | | |

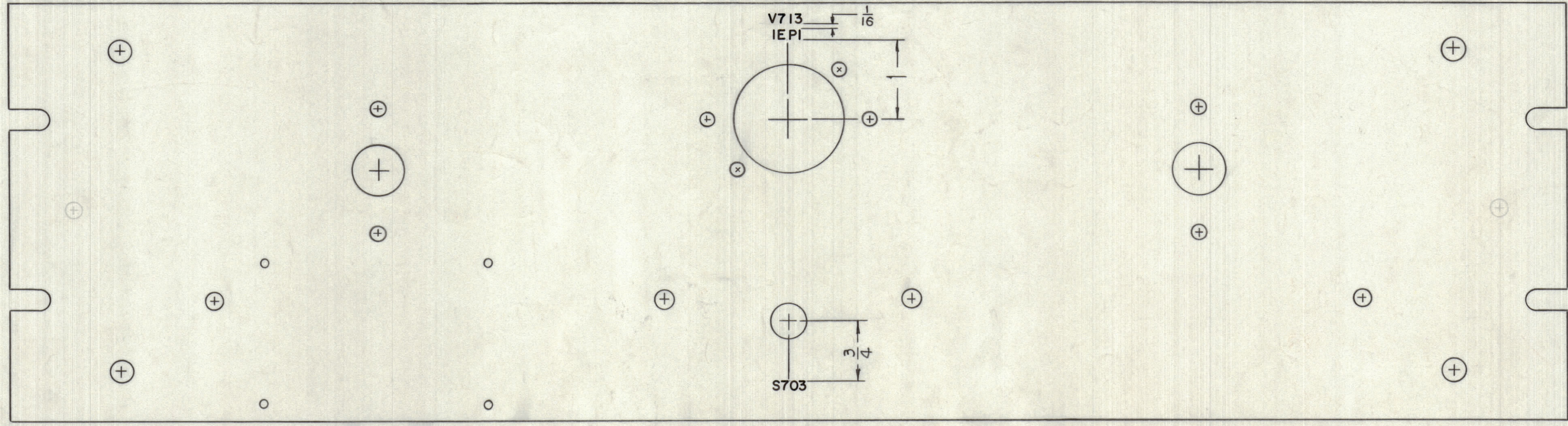

REAR VIEW OF PANAL SHOWN
 (TO BE SILK SCREENED)
 OR EQUIVALENT
 PER TMC SPEC-S 544
 MARKING PROCESS: AS PER TMC SPECIFICATION S-727
 ALL LETTERING TO BE 1/8 HIGH BLACK GOTHIC,
 CENTERED ON HOLES UNLESS OTHERWISE SPECIFIED

NOTICE TO PERSONS RECEIVING THIS DRAWING
 THE TECHNICAL MATERIEL CORPORATION claims proprietary right in the material disclosed herein. This drawing is issued in confidence for engineering information only and may not be reproduced or used to manufacture anything shown hereon without permission from THE TECHNICAL MATERIEL CORPORATION to the user. This drawing is loaned for mutual assistance and is subject to recall at any time.
 Property of:
 THE TECHNICAL MATERIEL CORPORATION
 MAMARONECK, NEW YORK

Ref MS-2205 (8)

| | | | | | | | |
|-----------------------------|------|--|--|---------|--------|---------|-----------|
| SYM | ZONE | DESCRIPTION | DATE | CH. NO. | DRAFTS | CHECKER | ENG. APP. |
| A | | Dwg. made as 2 nd Sheet of (LD-732) | 4-7-61 | 4598 | RL | | |
| UNLESS OTHERWISE SPECIFIED: | | | SCALE | | | | |
| DIMENSIONS ARE IN INCHES | | | MAXIMUM ALLOWABLE TOLERANCES HAVE BEEN DETERMINED AND ANY DEVIATIONS WILL BE CAUSE FOR REJECTION. REMOVE ALL BURRS & SHARP EDGES | | | | |
| TOLERANCES ON | | | | | | | |
| FRACTIONS ± 1/64 | | | DECIMALS ± .005 | | | | |
| | | | ANGLES ± 1/2° | | | | |

| REQ. ITEM | PART NO. | DESCRIPTION | SYMBOL |
|--|----------|--|--------|
| THE TECHNICAL MATERIEL CORP. MAMARONECK, NEW YORK | | | |
| STOCK SIZE | | | |
| LETTERING FRONT PANEL | | | |
| REAR | | | |
| MATERIAL | | | |
| UZZO | | | |
| DRAWN | | CHECKED | |
| LD-732 | | A | |
| TYPE & TEMPER | | HEAT TREAT. SPEC. | |
| FINISH & SPEC. NO. | | ELEC. DES. APP. MECH. DES. APP. SHEET 2 OF 2 | |