

IF IT IS FOUND DESIRABLE TO CHANGE ANY TOLERANCE OR OTHER DETAIL SPECIFIED ON THIS DRAWING NOTIFY THE PURCHASER PROMPTLY.  
 MAXIMUM ALLOWABLE TOLERANCES HAVE BEEN DETERMINED AND DEVIATIONS WILL BE CAUSE FOR REJECTION. REMOVE ALL BURRS AND SHARP EDGES

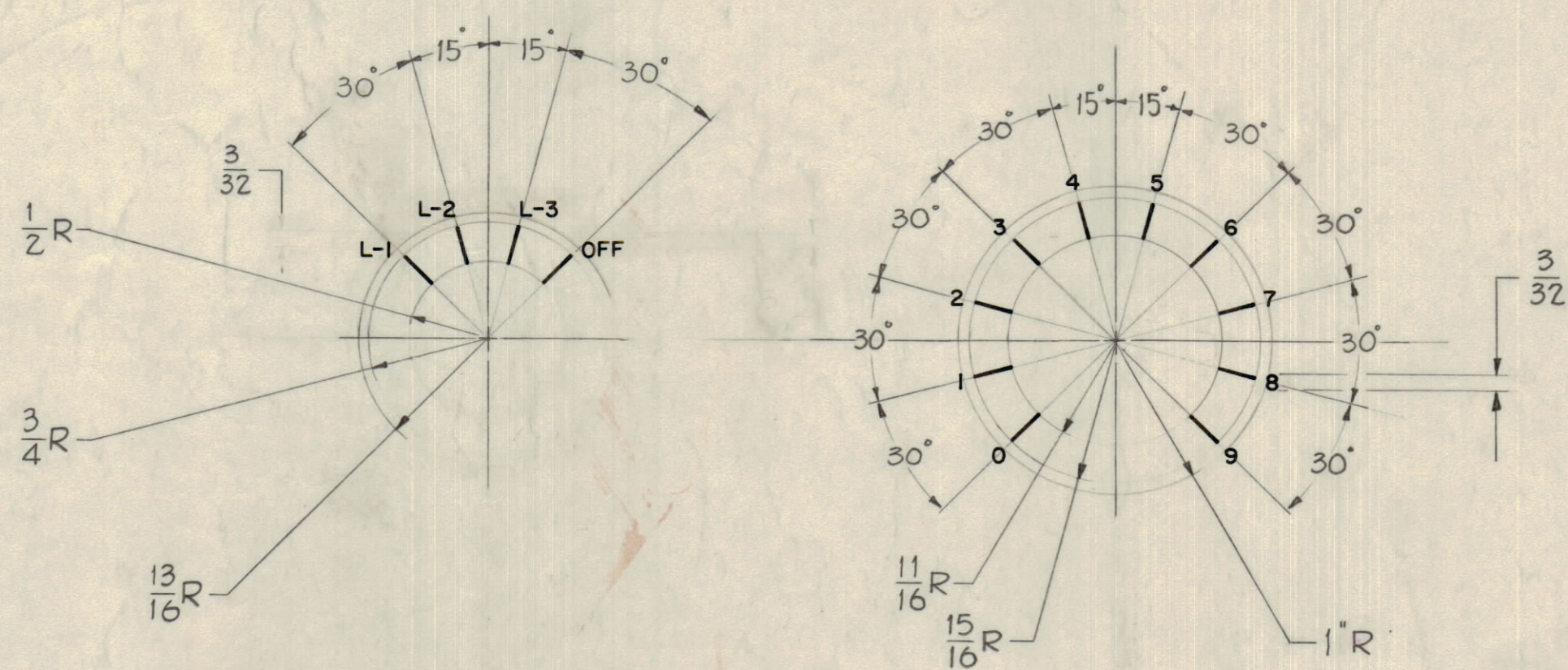

THIS DETAIL IS USED FOR KILOCYCLES & HUNDREDS OF CYCLES.

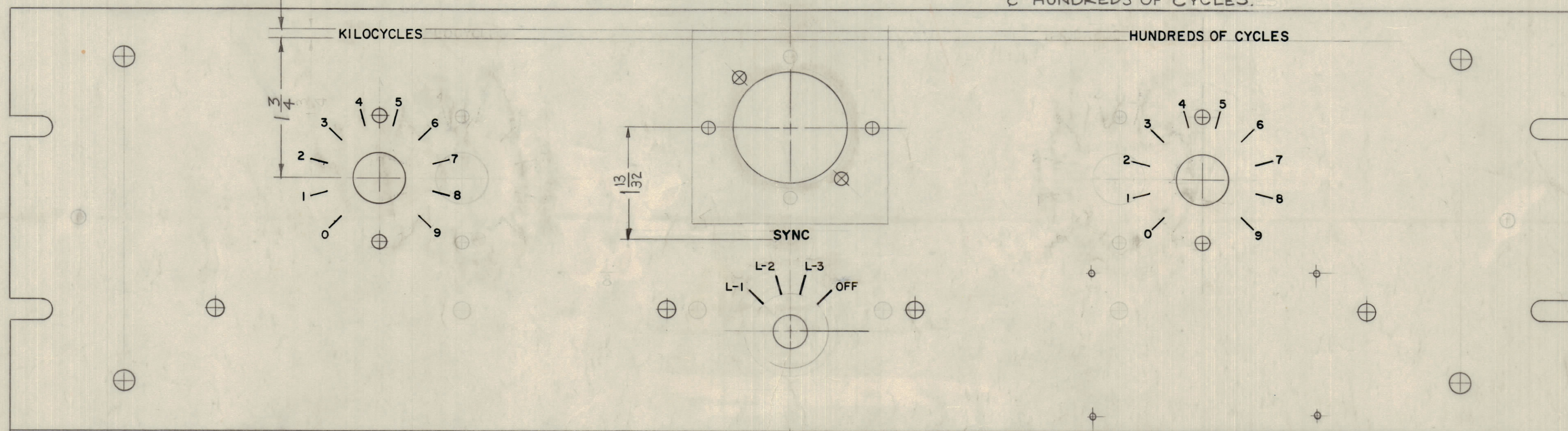

FRONT VIEW OF PANEL SHOWN (TO BE ENGRAVED) PER TMC SPEC- 5566

- NOTES ~ 1 ~ ALL LETTER GROUPS TO BE CENTERED ON HOLES.  
 2 ~ ALL LINES TO BE WHITE FILLED.  
 3 ~ ENGRAVING TO BE GOTHIC WHITE FILLED SIZES SHOWN ON CHART.

HEIGHT OF LETTER	DEPTH OF STROKE	WIDTH OF STROKE
3/32	.010	.015
1/8	.010	.020
LINES	.010	.015

NOTICE TO PERSONS RECEIVING THIS DRAWING

THE TECHNICAL MATERIEL CORPORATION claims proprietary right in the material disclosed herein. This drawing is issued in confidence for engineering information only and may not be reproduced or used to manufacture anything shown herein without permission from THE TECHNICAL MATERIEL CORPORATION to the user. This drawing is loaned for mutual assistance and is subject to recall at any time.

Property of:  
 THE TECHNICAL MATERIEL CORPORATION  
 MAMARONECK, NEW YORK

REF ~ FRONT PANEL, MACHINING ~ MS-2205

REQ. ITEM	PART NO.	DESCRIPTION	SYMBOL
		THE TECHNICAL MATERIEL CORP. MAMARONECK, NEW YORK	
		STOCK SIZE	
		FRONT PANEL ENGRAVING	
		MATERIAL	WEIGHT PER PC.
		CLL-1 (FRONT)	
		TYPE & TEMPER	
		DRAWN	ELEC. DES. APP. MECH. DES. APP.
		CHECKED	FINAL APPROVAL
		HEAT TREAT. SPEC.	
		FINISH & SPEC. NO.	

1	CLL-1	PROJECT NO.	ASSY. NO.	2-2-60	DATE
REQ PER UNIT	MODEL	USED ON			

A	Sheet No 2 Added	4-8-61	4598	RU		
ISSUE	ITEM	CHANGED FROM	DATE	CH. NO.	DRAFTER	CHECKER
TOLERANCES		SCALE:				
ALL OTHERS	DEC. DIM. ± FRAC. DIM. ± ANGULAR DIM. ±	DRILL PUNCH, COMMERCIAL STOCK SIZES AND MANUFACTURERS TOLERANCES ARE NOT INCLUDED.				