

LD-446 A

NOTICE TO PERSONS RECEIVING THIS DRAWING

THE TECHNICAL MATERIEL CORPORATION claims proprietary right in the material disclosed hereon. This drawing is issued in confidence for engineering information only and may not be reproduced or used to manufacture anything shown hereon without permission from THE TECHNICAL MATERIEL CORPORATION to the user. This drawing is loaned for mutual assistance and is subject to recall at any time.

Property of:
 THE TECHNICAL MATERIEL CORPORATION
 MAMARONECK, NEW YORK

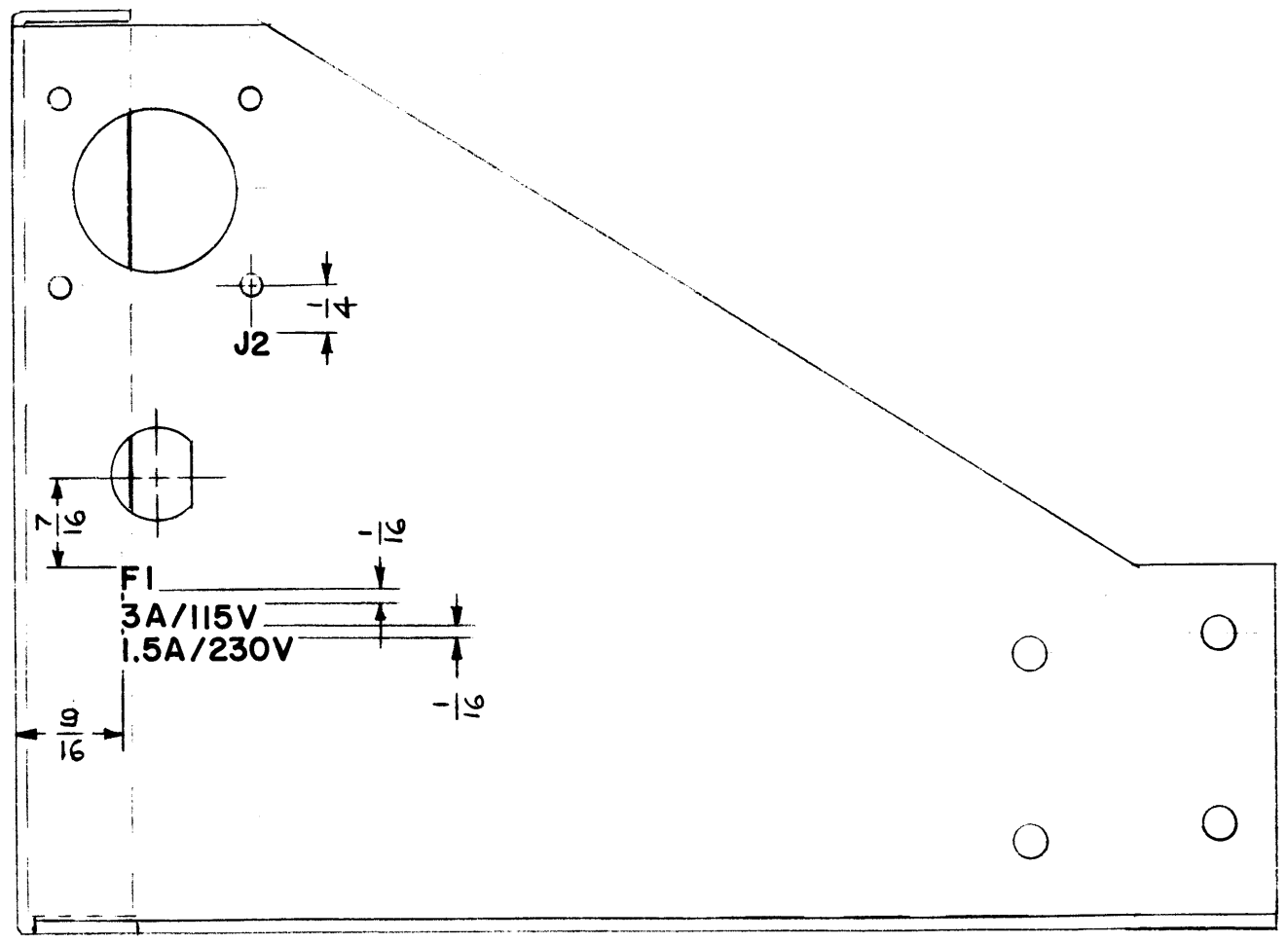

OUTSIDE, REAR VIEW

LETTERING 1/8 HIGH BLACK GOTHIC

REF-MS-1328(B)

A	2	DIMS. ADD. TO LETT. FI WAS 3A	9.3.64	12284	hTB	@	
ISSUE	ITEM	CHANGED FROM	DATE	CH. NO.	DRAFTS	CHECKER	ENG. APP.
TOLERANCES		SCALE:					
DEC. DIM. ±		MAXIMUM ALLOWABLE TOLERANCES HAVE BEEN DETERMINED AND ANY DEVIATIONS WILL BE CAUSE FOR REJECTION. REMOVE ALL BURRS AND SHARP EDGES					
FRAC. DIM. ±							
ANGULAR DIM. ±							

1	MSR-4				
REQ. PER UNIT	MODEL	PROJECT NO.	ASS'Y. NO.	DATE	
USED ON					

REQ. ITEM	PART NO.	DESCRIPTION	SYMBOL
		THE TECHNICAL MATERIEL CORP. MAMARONECK, NEW YORK	
STOCK SIZE		LETTERING, RIGHT SIDE	
MATERIAL		PLATE (MSR-4)	
		168/29/58	
TYPE & TEMPER	HEAT TREAT. SPEC.	DRAWN	CHECKED
FINISH & SPEC. NO.	ELEC. DES. APP.	MECH. DES. APP.	FINAL APPROVAL
			LD-446 A