

5

4

3

2

1

| REVISIONS |     |                       |         |          |       |      |      |
|-----------|-----|-----------------------|---------|----------|-------|------|------|
| ZONE      | LTR | DESCRIPTION           | DATE    | E.M.N.NO | DRAFT | CHKD | APPD |
|           | Ø   | ORIG RELEASE FOR PROD | 11/3/72 |          | CV    |      |      |

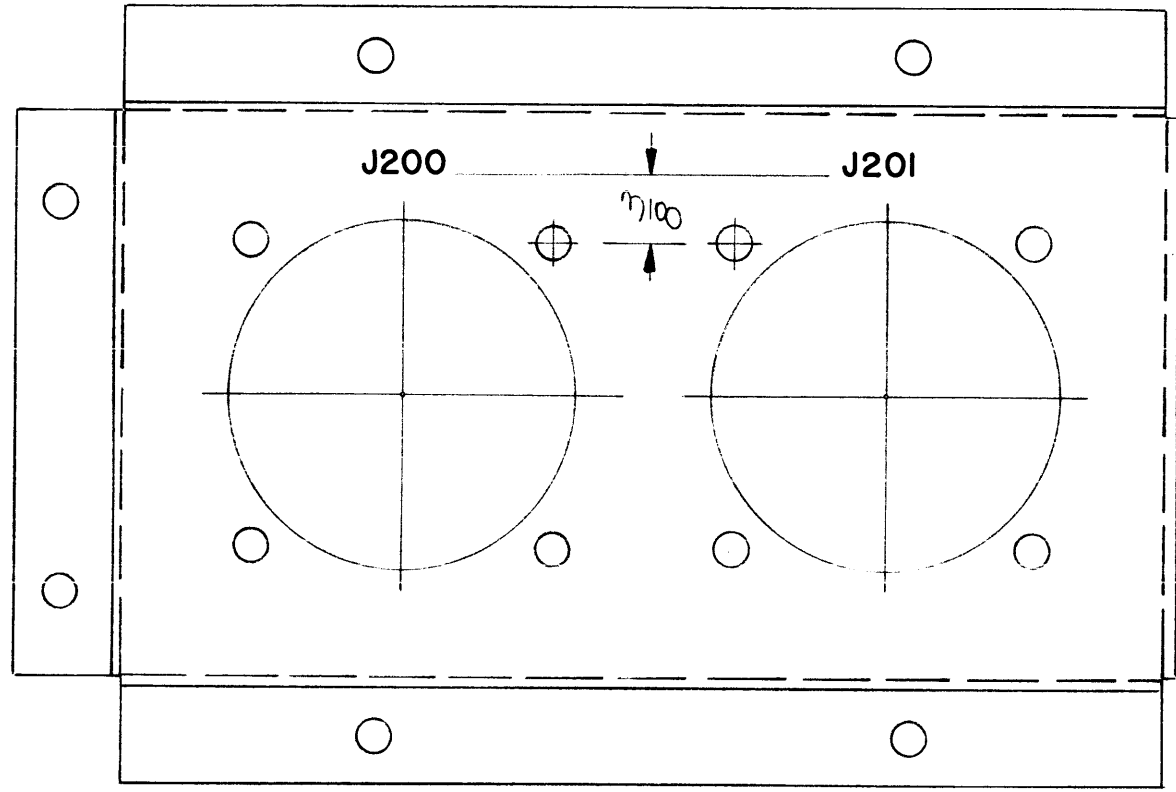

MARKING PROCESS: AS PER TMC SPECIFICATION S727  
 LETTERING: 1/8 HIGH BLACK GOTHIC, LOCATED AS SHOWN

| 1           | MFTRIOKE5 AX5142 |           |
|-------------|------------------|-----------|
| QTY / UNIT  | MODEL USED ON    | ASS'Y NO. |
| APPLICATION |                  |           |
|             | CODE             |           |

**NOTICE TO PERSONS RECEIVING THIS DRAWING**  
 THE TECHNICAL MATERIEL CORPORATION claims proprietary right in the material disclosed hereon. This drawing is issued in confidence for engineering information only and may not be reproduced or used to manufacture anything shown hereon without permission from THE TECHNICAL MATERIEL CORPORATION to the user. This drawing is loaned for mutual assistance and is subject to recall at any time.

REF MS 6291

UNLESS OTHERWISE SPECIFIED DIMENSIONS ARE IN INCHES AND INCLUDE CHEMICALLY APPLIED OR PLATED FINISHES

| DECIMALS    | FRACTIONS    |
|-------------|--------------|
| .X ± .05    | 1/64         |
| .XX ± .01   | TOLS. ANGLES |
| .XXX ± .005 | 0° -30'      |

MATERIAL

FINISH

| REQ'D                 | ITEM | PART NUMBER | DESCRIPTION                  | SYM.            |
|-----------------------|------|-------------|------------------------------|-----------------|
| F.B. LIST OF MATERIAL |      |             |                              |                 |
| FINAL APPROVAL        |      | DATE        | THE TECHNICAL MATERIEL CORP. |                 |
| MECH. DES.            |      | DATE        | MAMARONECK, NEW YORK         |                 |
| ELECT. DES.           |      | DATE        | MARKING CONN. MTG. BRKT.     |                 |
| CHECKED               |      | DATE        | SIZE                         | CODE IDENT. NO. |
| DRAWN                 |      | DATE        | B                            | 82679           |
|                       |      |             | DWG NO.                      | LD 2496         |
|                       |      |             | ISSUE                        | Ø               |
| SCALE 1:1             |      |             | SHEET                        | OF              |

5

4

3

2

1