

A		REVISIONS					
SYM	DESCRIPTION	DATE	E.M.N. NO.	DRAFT	CHKD	APPD	
X	EXPERIMENTAL RELEASE	6-6-66	X	MD			
8	ORIGINAL RELEASE FOR PRODUCTION	11-11-66	4	WTO		FB	
A	ADDED CR5002 & 4 HOLES	3/11/68	18803	H.S.		FB	

LD2097

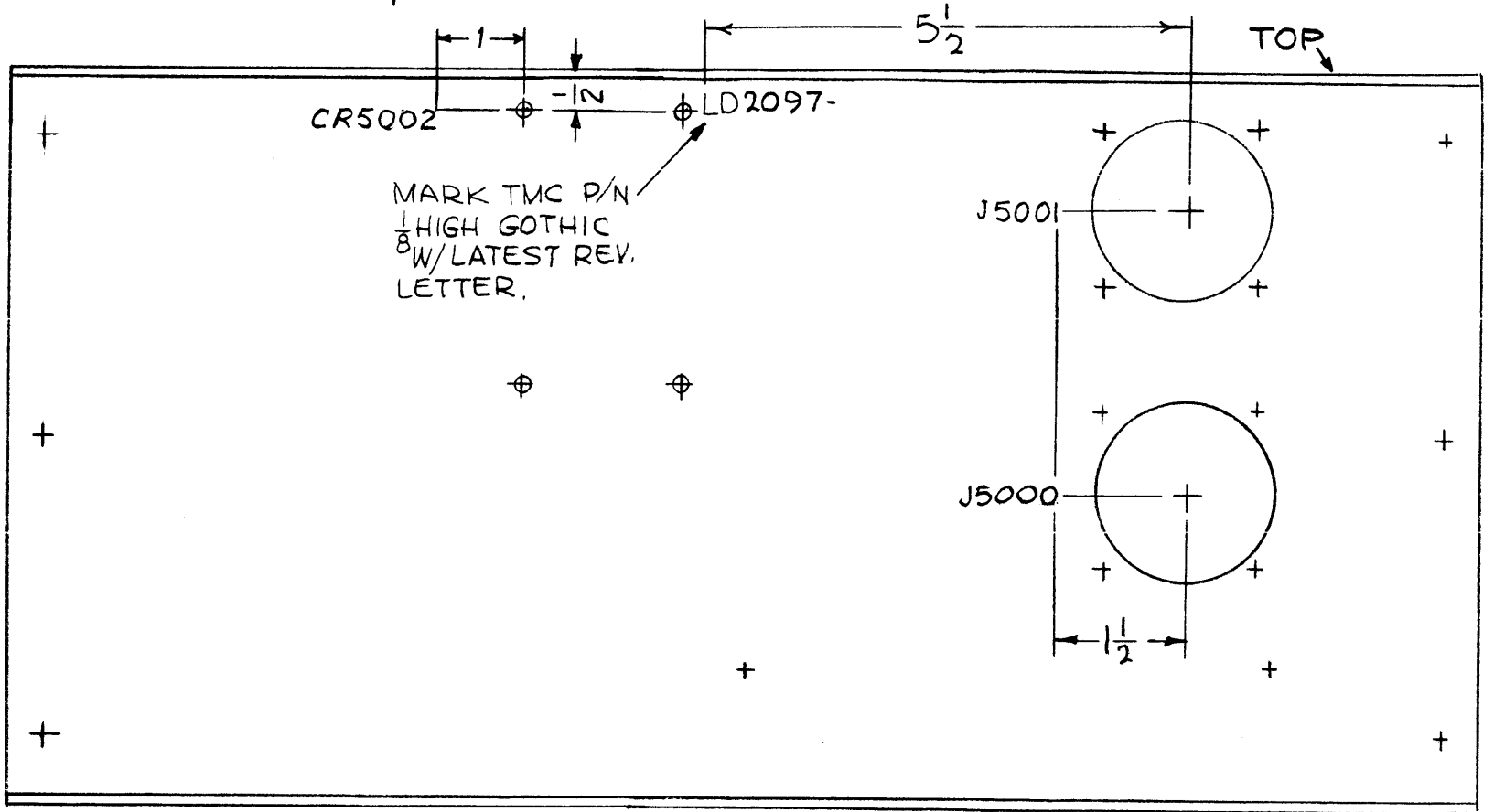
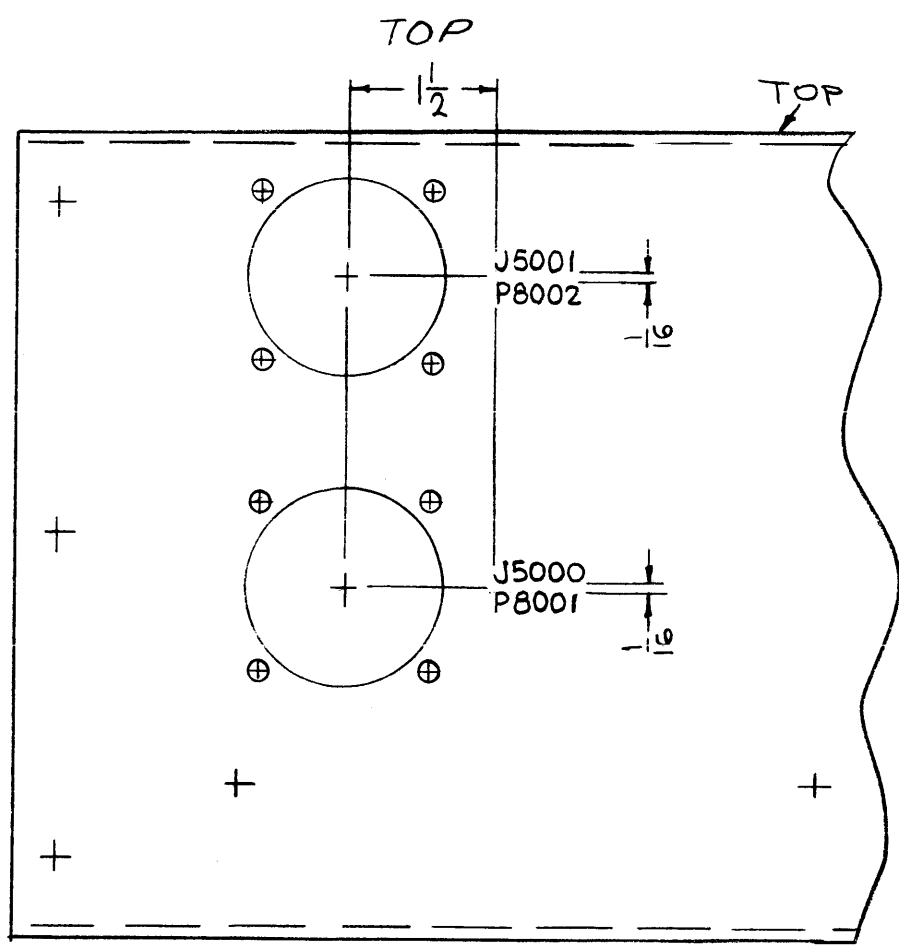

MARKING PROCESS: AS PER TMC SPECIFICATION S-727.
LETTERING: 1/8 HIGH BLACK GOTHIC, LOCATED AS SHOWN.

REF: MS 4972-

REQ'D.	ITEM	PART NUMBER	DESCRIPTION	SYMBOL
F. BUDETTI LIST OF MATERIAL				
MATERIAL			THE TECHNICAL MATERIEL CORP. MAMARONECK, NEW YORK	
FINISH			TITLE MARKING, PLATE, REAR AS PER TMC SPEC. S-727	
UNLESS OTHERWISE SPECIFIED DIMENSIONS ARE IN INCHES AND INCLUDE CHEMICALLY APPLIED OR PLATED FINISHES			DRAWN: [Signature] CHECKED: [Signature] ELECT. DES: [Signature] MECH. DES: [Signature]	DATE: 6- DATE: 11-9-66 DATE:
DECIMALS .X ± .05 .XX ± .01 .XXX ± .005			FRACTIONS ± 1/64 ANGLES ± 0° 30'	FINAL APPROVAL: [Signature] DATE: 11/10/66 SHEET: LD2097 REV. LTR.: A

Q'TY./UNIT	MODEL USED ON	ASS'Y. NO.
SCALE 1/2:1	CODE A	

THE CONTENTS OF THIS DRAWING ARE THE EXCLUSIVE PROPERTY OF THE TECHNICAL MATERIEL CORP. ITS UNAUTHORIZED USE OR REPRODUCTION IN WHOLE OR IN PART IS STRICTLY FORBIDDEN.

NOTES