

REVISIONS							
ZONE	SYM	DESCRIPTION	DATE	E.M.N. NO.	DRAFT	CHKD	APPD
D4	X1	24VAC WAS -24V	1/25/66		JL		JL
Q6	X2	F1007 & 8 WERE "AC LINE" FUSES.	3/31/66		JL		JL
	Ø	ORIGINAL RELEASE FOR PRODUCTION	4-11-66	Ø	WV		JL

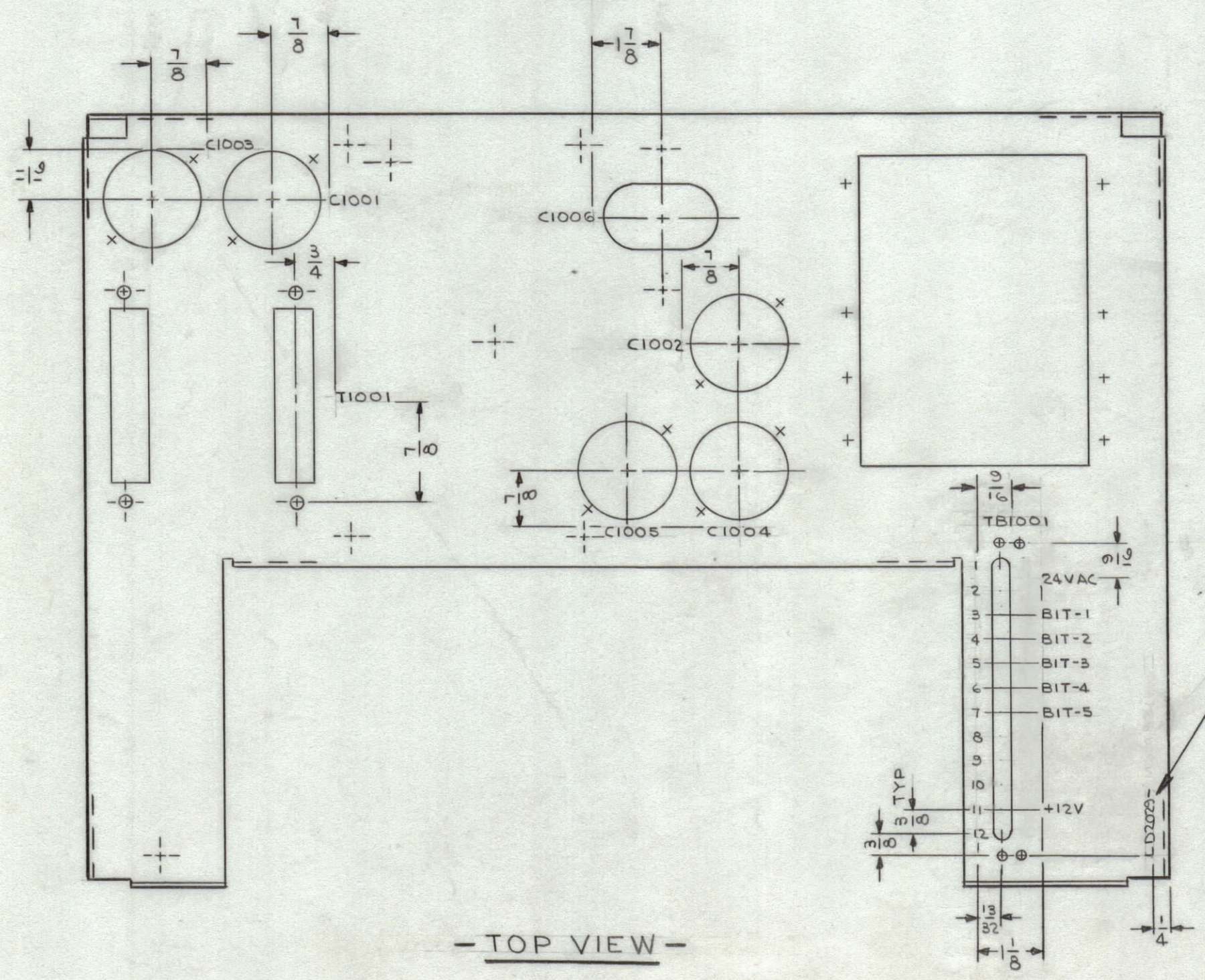
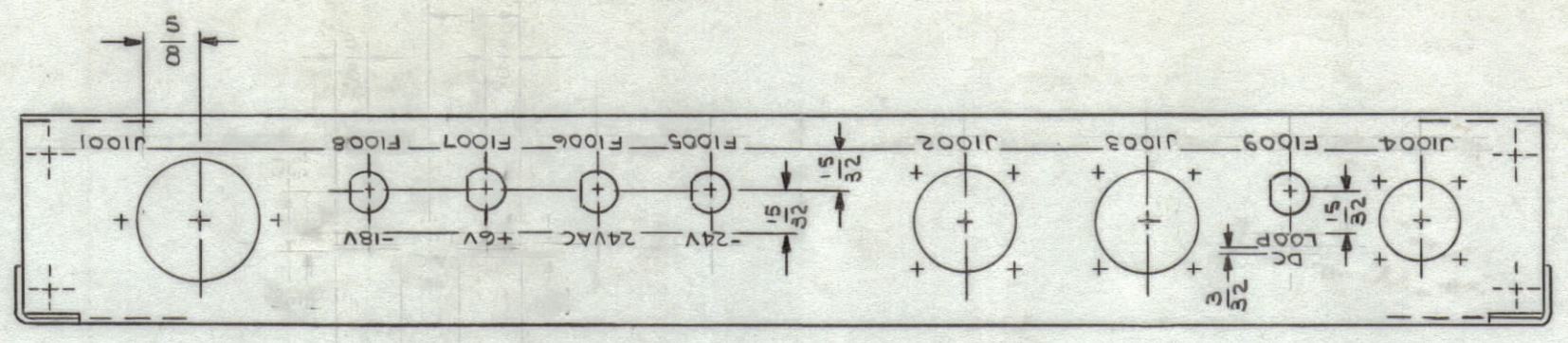

- TOP VIEW -

UNLESS OTHERWISE SPECIFIED

- 1-MARKING PROCESS: AS PER TMC SPECIFICATION S-727.
- 2-LETTERING: 1/8 HIGH BLACK GOTHIC, LOCATED AS SHOWN.

NOTES

1	RTPH-1	A5340
Q'TY./UNIT	MODEL USED ON	ASS'Y. NO.
SCALE 1/2	CODE	
THE CONTENTS OF THIS DRAWING ARE THE EXCLUSIVE PROPERTY OF THE TECHNICAL MATERIEL CORP. ITS UNAUTHORIZED USE OR REPRODUCTION IN WHOLE OR IN PART IS STRICTLY FORBIDDEN.		

REF. MS4821

REQ'D.	ITEM	PART NUMBER	DESCRIPTION	SYMBOL
F.E. EATON LIST OF MATERIAL				
MATERIAL		THE TECHNICAL MATERIEL CORP. MAMARONECK, NEW YORK		
FINISH		TITLE MARKING-CHASSIS, ELECT., MAIN		
UNLESS OTHERWISE SPECIFIED DIMENSIONS ARE IN INCHES AND INCLUDE CHEMICALLY APPLIED OR PLATED FINISHES		DRAWN J. LESHINSKI	DATE 12/3/65	FINAL APPROVAL <i>[Signature]</i>
DECIMALS .X ± .05 .XX ± .01 .XXX ± .005		CHECKED <i>[Signature]</i>	DATE 4-5-66	DATE 4/7/66
FRACTIONS ± 1/64 ANGLES ± 0° 30'		ELECT. DES. <i>[Signature]</i>	DATE 4/6/66	DATE
TOLERANCES		MECH. DES. <i>[Signature]</i>	DATE	DATE
SHEET 1 OF 2				REV. LTR.

LD2029 Ø

REVISIONS					
ZONE	SYM	DESCRIPTION	DATE	E.M.N. NO.	APPD
	X1	SEE SHEET 1 OF 2	1/25/66		JL
	X2	SEE SHEET 1 OF 2	3/31/66		JL
	Ø	ORIGINAL RELEASE FOR PROD	4/1/66	Ø	JL

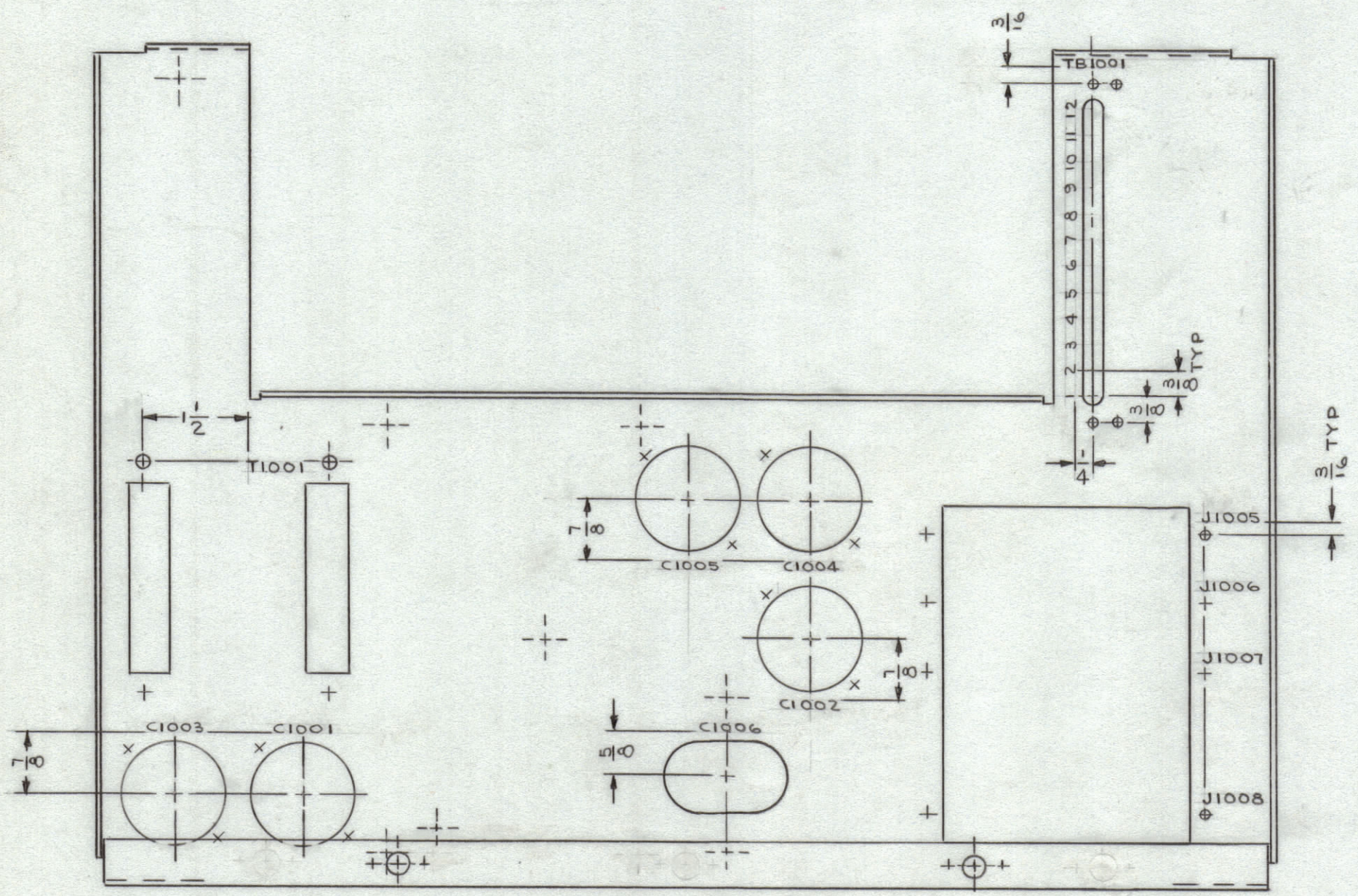
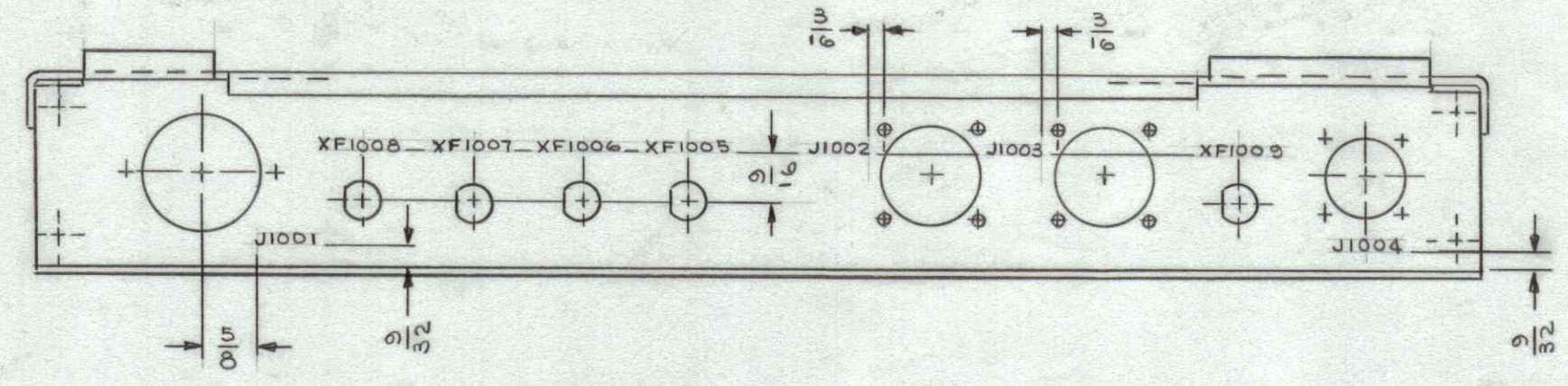

- BOTTOM VIEW -

- UNLESS OTHERWISE SPECIFIED -

- 1-MARKING PROCESS: AS PER TMC SPECIFICATION S-727.
- 2-LETTERING: 1/8 HIGH BLACK GOTHIC, LOCATED AS SHOWN.

NOTES

1	RTPH-1	A5340
Q'TY./UNIT	MODEL USED ON	ASS'Y. NO.
SCALE 1/2	CODE	
THE CONTENTS OF THIS DRAWING ARE THE EXCLUSIVE PROPERTY OF THE TECHNICAL MATERIEL CORP. ITS UNAUTHORIZED USE OR REPRODUCTION IN WHOLE OR IN PART IS STRICTLY FORBIDDEN.		

REF. MS 4821

REQ'D.	ITEM	PART NUMBER	DESCRIPTION	SYMBOL
F.E. EATON LIST OF MATERIAL				
MATERIAL		THE TECHNICAL MATERIEL CORP. MAMARONECK, NEW YORK		
FINISH		TITLE MARKING - CHASSIS, ELECT., MAIN		
UNLESS OTHERWISE SPECIFIED DIMENSIONS ARE IN INCHES AND INCLUDE CHEMICALLY APPLIED OR PLATED FINISHES		DRAWN J. LESHINSKI	DATE 12/3/65	FINAL APPROVAL <i>[Signature]</i>
DECIMALS .X ± .05 .XX ± .01 .XXX ± .005		CHECKED <i>[Signature]</i>	DATE 4-5-66	DATE 4/1/66
FRACTIONS ± 1/64 ANGLES ± 0° 30'		ELECT. DES. <i>[Signature]</i>	DATE 4/1/66	DATE 4/1/66
TOLERANCES		MECH. DES. <i>[Signature]</i>	DATE 4/1/66	DATE 4/1/66
			SHEET 2 OF 2	REV. LTR.

LD2029