

REVISIONS					
ZONE	SYM	DESCRIPTION	DATE	E.M.N. NO.	APPD
	X1	XF9101 ADDED	8-3-65	X1	<i>[Signature]</i>
	Ø	ORIGINAL RELEASE FOR PRODUCTION	5/9/67	Ø	CV <i>[Signature]</i>

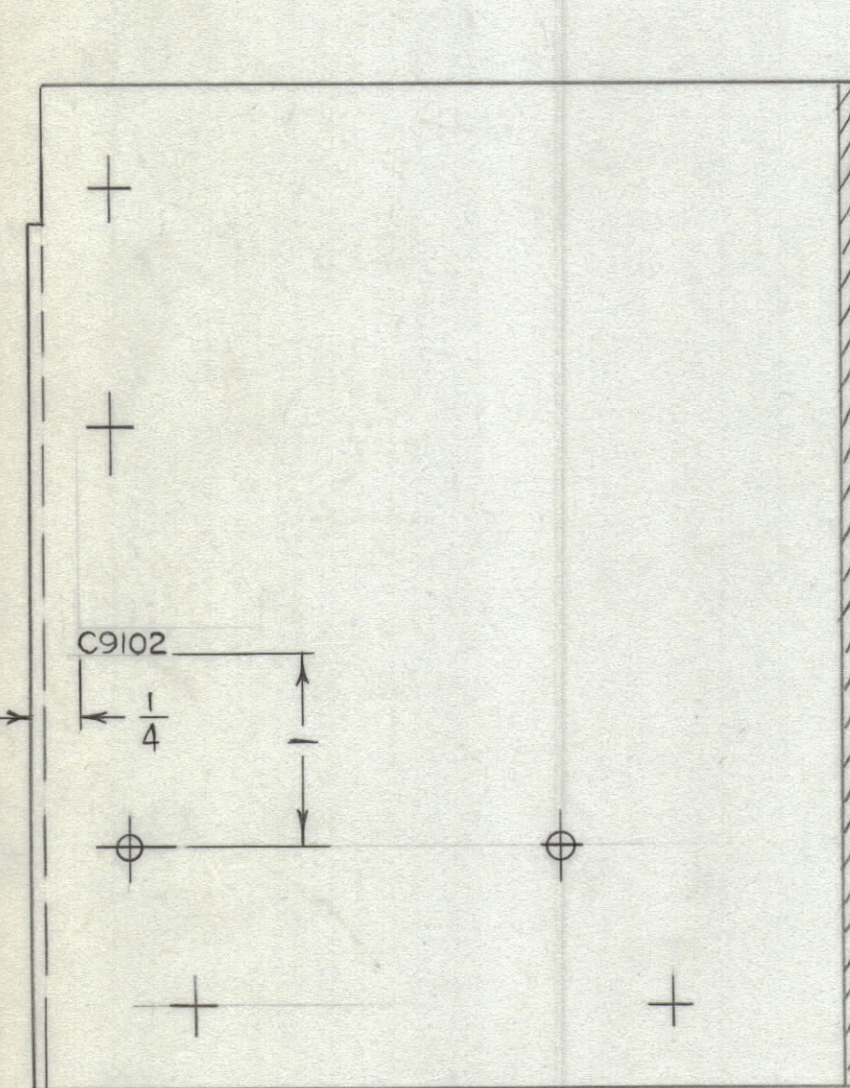

VIEW "A-A"

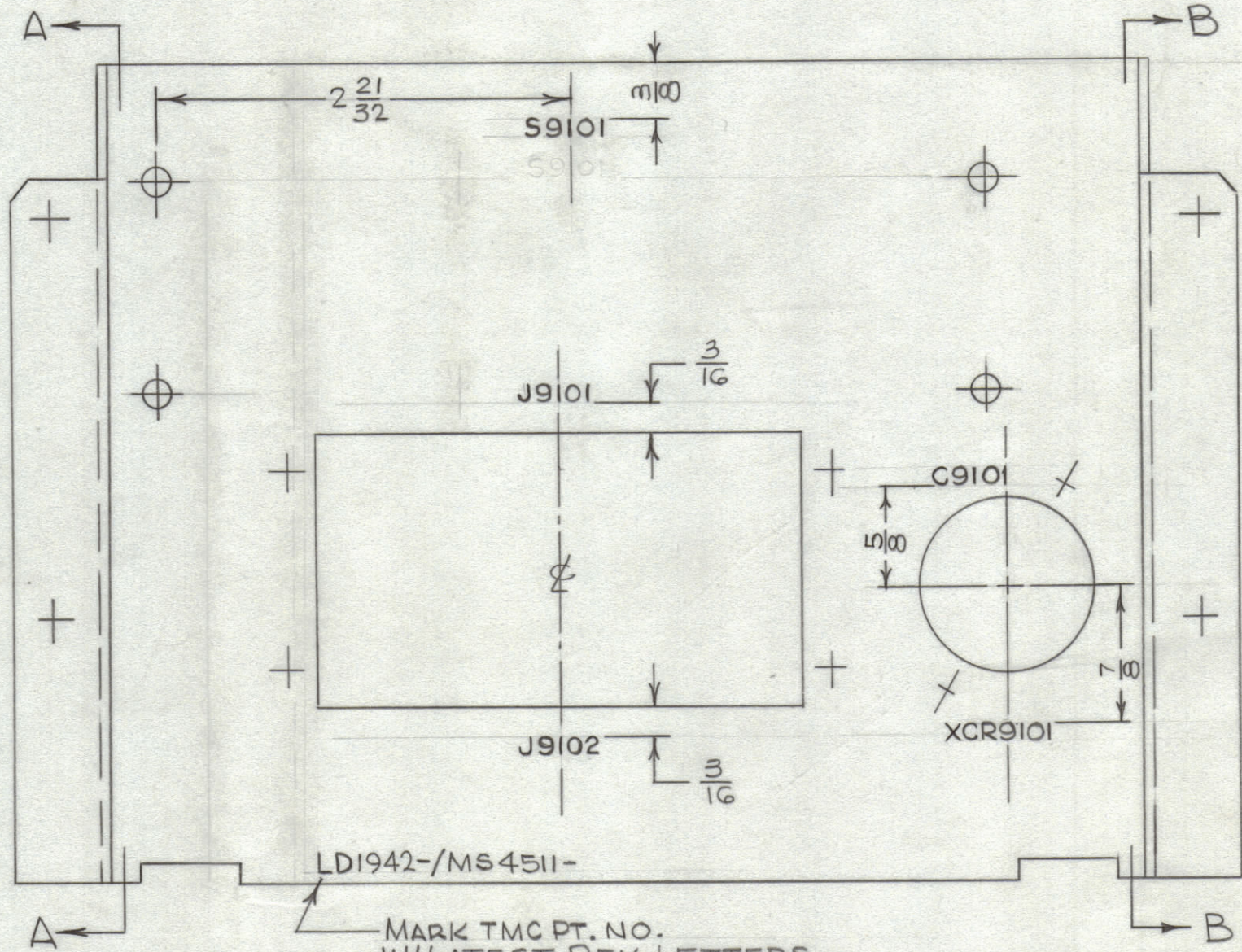

LD1942-MS4511-
 MARK TMC PT. NO.
 W/LATEST REV. LETTERS

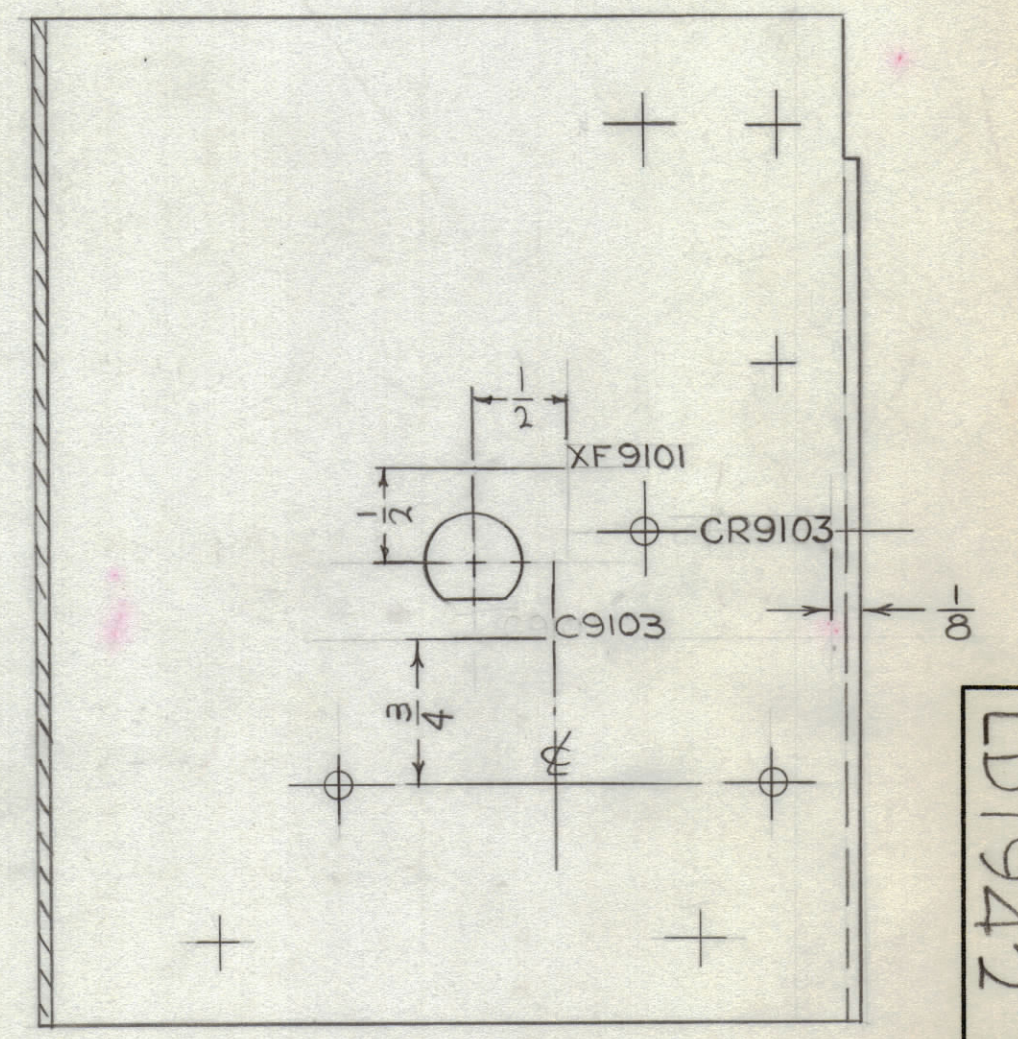

VIEW "B-B"

MARKING PROCESS: AS PER TMC SPECIFICATION S-727.
 LETTERING: 1/8 HIGH BLACK GOTHIC, LOCATED AS SHOWN.

REF.: MS4511

REQ'D.	ITEM	PART NUMBER	DESCRIPTION	SYMBOL
LIST OF MATERIAL				
MATERIAL		THE TECHNICAL MATERIEL CORP. MAMARONECK, NEW YORK		
FINISH		TITLE MARKING, CHASSIS, MAIN (INSIDE)		
UNLESS OTHERWISE SPECIFIED DIMENSIONS ARE IN INCHES AND INCLUDE CHEMICALLY APPLIED OR PLATED FINISHES		DRAWN H. AUSTIN	DATE 6-8-65	FINAL APPROVAL <i>[Signature]</i>
DECIMALS .X ± .05 .XX ± .01 .XXX ± .005		CHECKED	DATE	DATE 5/9/67
FRACTIONS ± 1/64 ANGLES ± 0° 30'		ELECT. DES.	DATE	DATE
TOLERANCES		MECH. DES.	DATE	DATE
SHEET 1 OF 2				REV. LTR.

Q'TY./UNIT	MODEL USED ON	ASS'Y. NO.
SCALE 1:1	TSTE-10K	

NOTES

THE CONTENTS OF THIS DRAWING ARE THE EXCLUSIVE PROPERTY OF THE TECHNICAL MATERIEL CORP. ITS UNAUTHORIZED USE OR REPRODUCTION IN WHOLE OR IN PART IS STRICTLY FORBIDDEN.

LD1942