

REVISIONS						
ZONE	SYM	DESCRIPTION	DATE	E.M.N. NO.	DRAFT	CHKD
	X	EXPERIMENTAL RELEASE	11-9-64	X	J.L.	
	Ø	ORIGINAL RELEASE FOR PRODUCTION	11-12-64	Ø	J.L.	

HEIGHT OF LETTERS	DEPTH OF STROKE	WIDTH OF STROKE
1/8	.010	.020
DOTS	.010	1/16 DIA.

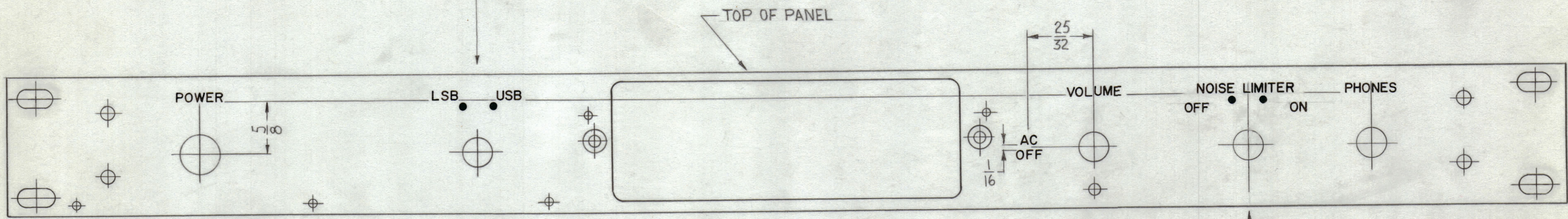
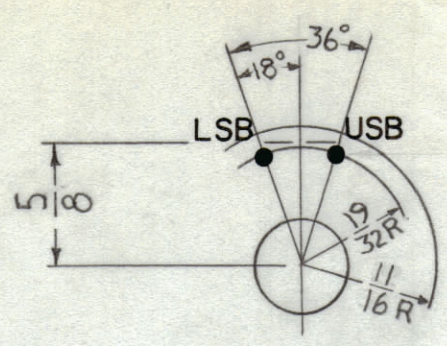

FRONT OF PANEL SHOWN

MARKING PROCESS: ENGRAVING AS PER TMC SPEC. S-566

UNLESS OTHERWISE SPECIFIED:

1. ALL LETTERING TO BE WHITE FILLED.
2. ALL DOTS WHITE FILLED.
3. ALL LETTER GROUPS TO BE CENTERED ON HOLES.
4. ENGRAVING TO BE GOTHIC, WHITE FILLED, SIZES SHOWN ON CHART.

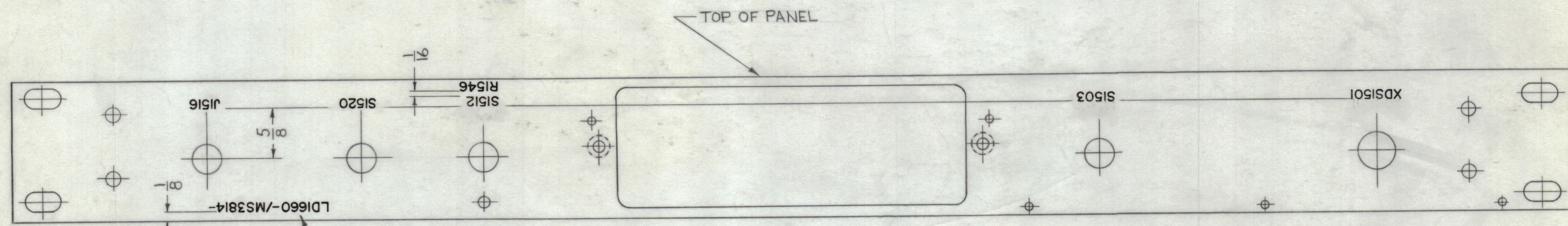
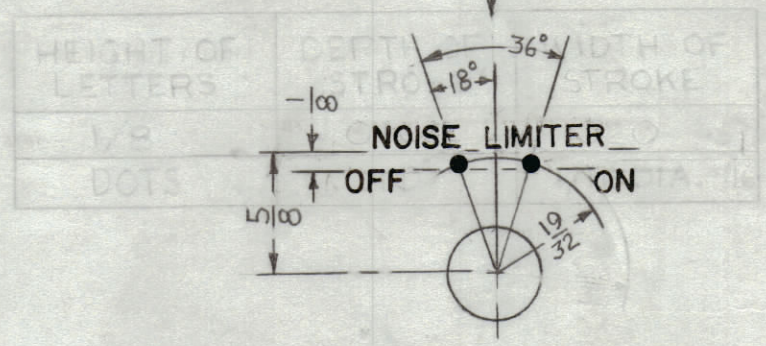

REAR OF PANEL SHOWN

MARK TMC PART NO. WITH LATEST REVISION LETTER

MARKING PROCESS: AS PER TMC SPECIFICATION S-727.  
 LETTERING: 1/8 HIGH BLACK GOTHIC, LOCATED AS SHOWN.

REF: M54133

REQ'D.	ITEM	PART NUMBER	DESCRIPTION	SYMBOL
LIST OF MATERIAL				
MATERIAL		THE TECHNICAL MATERIEL CORP. MAMARONECK, NEW YORK		
FINISH		TITLE MARKING, FRONT PANEL MARKING METHOD: FRONT(ENGRAVING) REAR(TMC#S727)		
DRAWN		J. Swana	DATE	11-6-64
CHECKED		[Signature]	DATE	11-12-64
ELECT. DES.		[Signature]	DATE	11/12/66
MECH. DES.		[Signature]	DATE	
		SHEET		LD1660
				REV. LTR.

QTY./UNIT	MODEL USED ON	ASSY. NO.
1	STR-2	
SCALE	CODE	
1:1	A	

THE CONTENTS OF THIS DRAWING ARE THE EXCLUSIVE PROPERTY OF THE TECHNICAL MATERIEL CORP. ITS UNAUTHORIZED USE OR REPRODUCTION IN WHOLE OR IN PART IS STRICTLY FORBIDDEN.

NOTES

LD1660