

REVISIONS						
ZONE	SYM	DESCRIPTION	DATE	E.M.N. NO.	DRAFT	CHKD
	X	EXPER. RELEASE	6-29-64	1		
	X <sub>1</sub>	(4) HOLES RELOCATED "ON #TUNE" ON AFC DELE. ON METER "OFF", "LSB", "USB" RELOCATED	7-27-64	X1	WB	
	Ø	ORIGINAL RELEASE FOR PRODUCTION	8-31-64	Ø	SL	

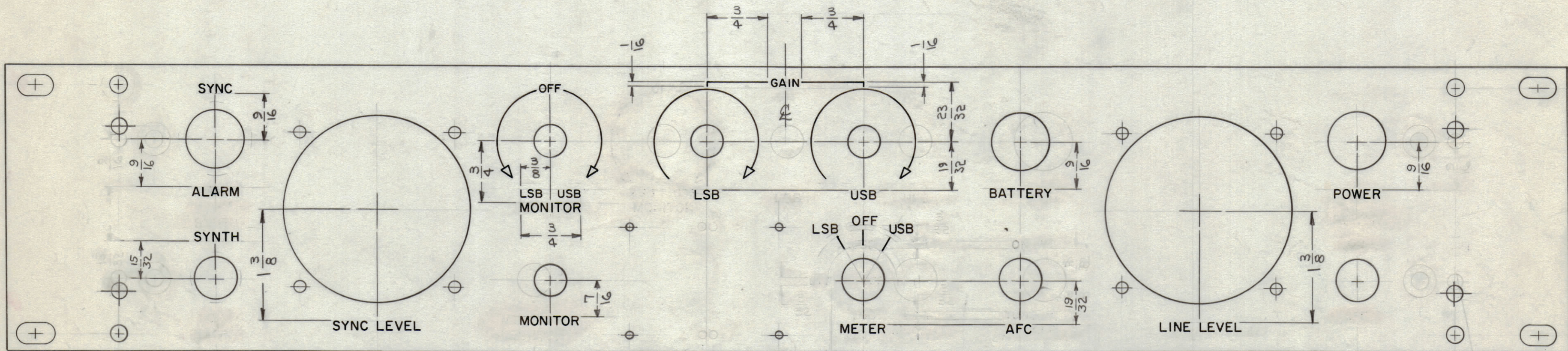

HEIGHT OF LETTERS	DEPTH OF STROKE	WIDTH OF STROKE
3/32	.010	.015
1/8	.010	.020
LINES	.010	.015
ARROWHEADS	.010	

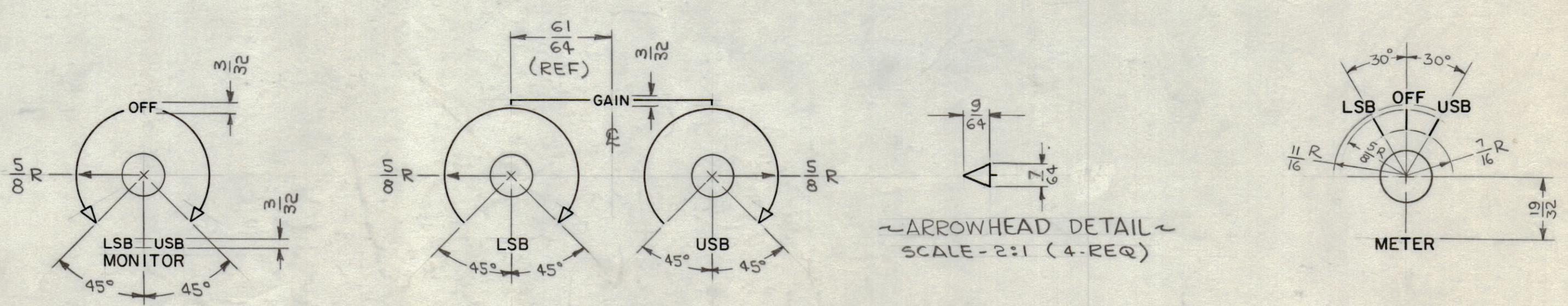

- ~ UNLESS OTHERWISE SPECIFIED ~
- 1- ALL ENGRAVING TO BE 1/8 HIGH, WHITE FILLED.
  - 2- ALL LINES TO BE WHITE FILLED.
  - 3- ARROWHEADS TO BE WHITE OUTLINE FILLED. (SEE DETAIL)
  - 4- 1/16" SPACING BETWEEN ALL LETTER GROUPS.

REF: MS 3952

REQ'D.	ITEM	PART NUMBER	DESCRIPTION	SYMBOL
GELLMAN LIST OF MATERIAL SK3136LD-2				
MATERIAL		THE TECHNICAL MATERIEL CORP. MAMARONECK, NEW YORK		
FINISH		TITLE MARKING, PANEL, FRONT MARKING PROCESS: ENGRAVING		
UNLESS OTHERWISE SPECIFIED DIMENSIONS ARE IN INCHES AND INCLUDE CHEMICALLY APPLIED OR PLATED FINISHES		DRAWN by <i>Seaman</i>	DATE 6-29-64	FINAL APPROVAL DATE 8-27-64
THE CONTENTS OF THIS DRAWING ARE THE EXCLUSIVE PROPERTY OF THE TECHNICAL MATERIEL CORP. ITS UNAUTHORIZED USE OR REPRODUCTION IN WHOLE OR IN PART IS STRICTLY FORBIDDEN.		CHECKED <i>WB</i>	DATE 8-27-64	DATE
DECIMALS .X ± .05 .XX ± .01 .XXX ± .005		TOLERANCES		ELECT. DES. MECH. DES.
		FRACTIONS ± 1/64 ANGLES ± 0° 30'		DATE
NOTES		SHEET 1 OF 2		REV. LTR.

LD157420



REVISIONS					
ZONE	SYM	DESCRIPTION	DATE	E.M.N. NO.	APPD
	X	EXPERIMENTAL RELEASE	7/24/64		
	X <sub>1</sub>	SEE SHEET 1 of 2	7-27-64		
	Ø	ORIGINAL RELEASE FOR PRODUCTION	8-31-64	Ø	AP

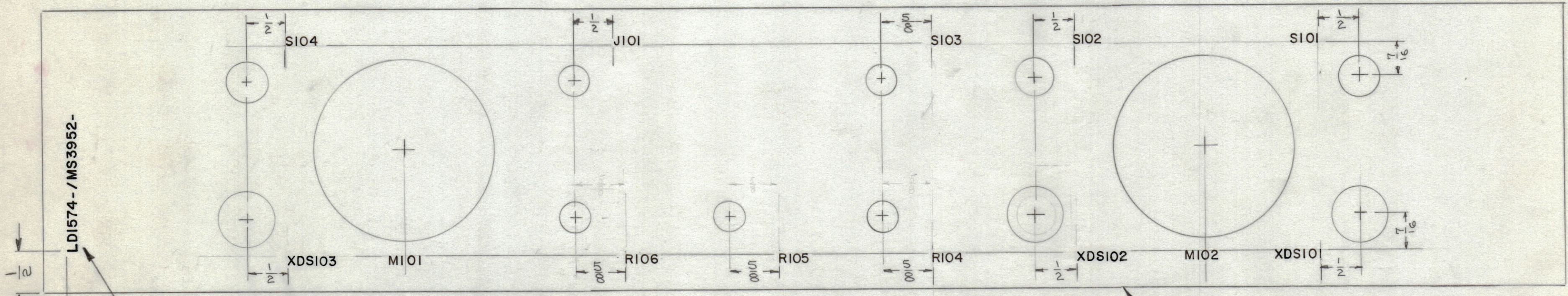

LDI574 - /MS3952-

MARK TMC PART NO. WITH LATEST REVISION LETTERS.

REAR OF PANEL SHOWN

Top of PANEL

LDI574 Ø

MARKING TO BE 1/8 HIGH BLACK GOTHIC PER TMC SPEC S727

NOTES

1	LFCA-1	
Q'TY./UNIT	MODEL USED ON	ASS'Y. NO.
SCALE	CODE	
#	A	

THE CONTENTS OF THIS DRAWING ARE THE EXCLUSIVE PROPERTY OF THE TECHNICAL MATERIEL CORP. ITS UNAUTHORIZED USE OR REPRODUCTION IN WHOLE OR IN PART IS STRICTLY FORBIDDEN.

REF: MS3952

REQ'D.	ITEM	PART NUMBER	DESCRIPTION	SYMBOL
GELLMAN LIST OF MATERIAL SK3136LD-2				
MATERIAL		THE TECHNICAL MATERIEL CORP. MAMARONECK, NEW YORK		
FINISH		TITLE MARKING, FRONT PANEL (REAR) MARKING PROCESS PER S727		
UNLESS OTHERWISE SPECIFIED DIMENSIONS ARE IN INCHES AND INCLUDE CHEMICALLY APPLIED OR PLATED FINISHES		DRAWN [Signature] DATE 8-27-64 FINAL APPROVAL [Signature] DATE 8-27-64		
DECIMALS .X ± .05 .XX ± .01 .XXX ± .005		TOLERANCES ± 1/64 ANGLES ± 0° 30'		ELECT. DES. [Signature] DATE MECH. DES. DATE
SHEET 2 of 2				LD1574 Ø
				REV. LTR.