

REVISIONS							
ZONE	SYM	DESCRIPTION	DATE	E.M.N. NO.	DRAFT	CHKD	APPD
	K1	REVISED INTERIOR LETTERING	7-31-64		T.R.	J.L.D.	T.R.
	O	ORIGINAL RELEASE FOR PRODUCTION	4-20-64	0	A.M.		
C4	A	SYMBOL XV201 & J202 RELOCATED	7-13-64	11692	J.P.	J.P.	J.P.

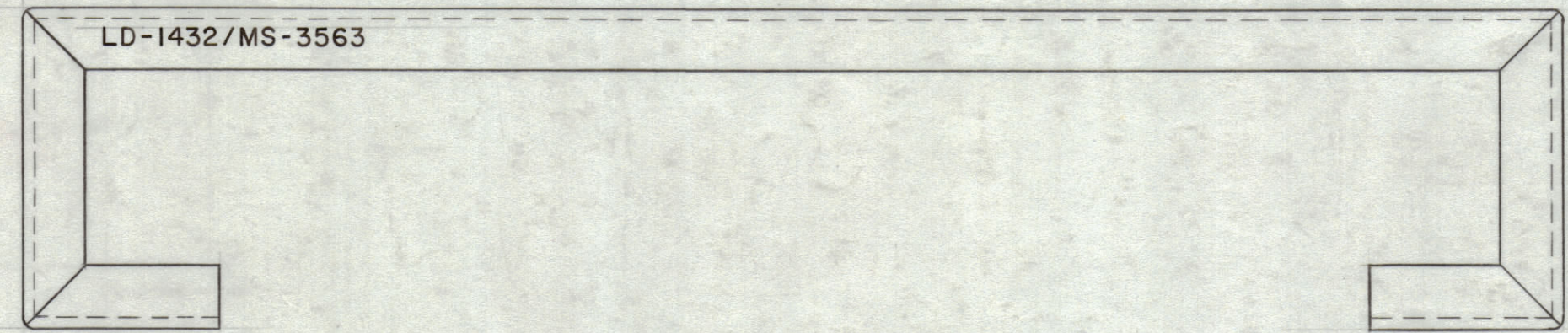

NOTE:  
 1. MARKING PROCESS: AS PER TMC SPEC. S-727.  
 2. LETTERING: 1/8 HIGH BLACK GOTHIC LOCATED AS SHOWN.  
 3. ALL LETTER GROUPS TO BE CENTERED ON HOLE  $\phi$ .

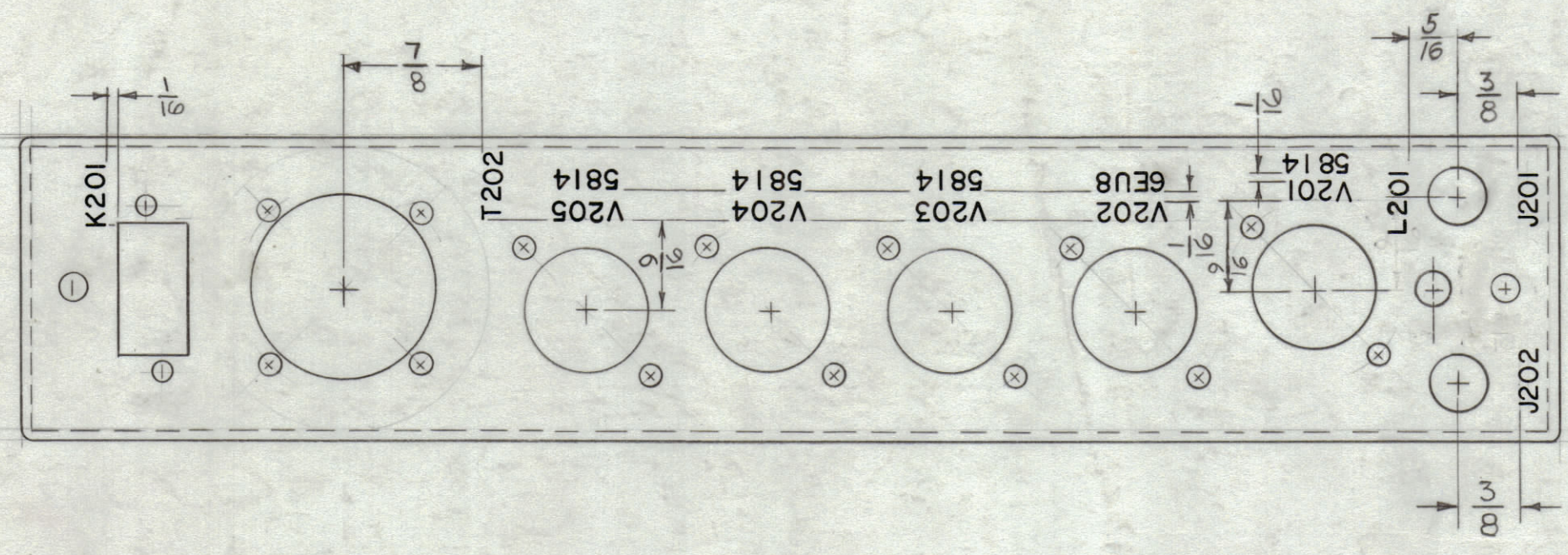
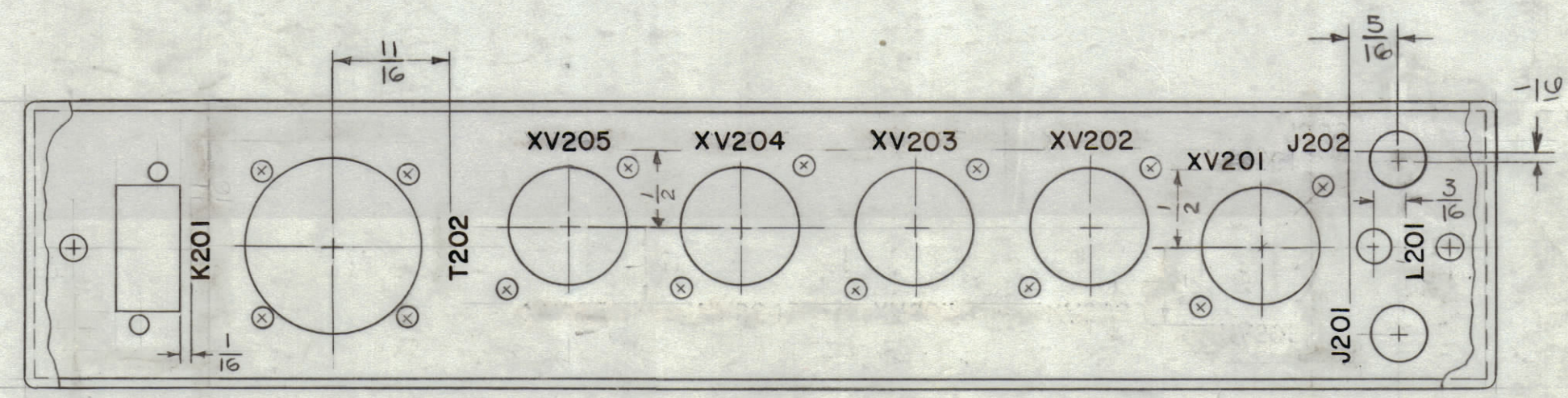

REF: MS-3563

REQ'D.	ITEM	PART NUMBER	DESCRIPTION	SYMBOL
<b>AALTONEN LIST OF MATERIAL</b>				
MATERIAL		THE TECHNICAL MATERIEL CORP. MAMARONECK, NEW YORK		
FINISH		TITLE: MARKING, CHASSIS, ELECTRICAL MARKING METHOD: PER TMC SPEC. S-727		
UNLESS OTHERWISE SPECIFIED DIMENSIONS ARE IN INCHES AND INCLUDE CHEMICALLY APPLIED OR PLATED FINISHES		DRAWN T. RAMIREZ	DATE 11/8/63	FINAL APPROVAL R.P.
DECIMALS .X ± .05 .XX ± .01 .XXX ± .005		CHECKED A	DATE 3-12-64	DATE 4/23/64
FRACTIONS ± 1/64 ANGLES ± 0° 30'		ELECT. DES. J.P.	DATE 3/14/64	DATE 7/28/64
TOLERANCES		MECH. DES. J.P.	DATE	DATE
NOTES		SHEET		REV. LTR.

4	MSA-1	AX-469
QTY./UNIT	MODEL USED ON	ASS'Y. NO.
SCALE 1:1	CODE A	

THE CONTENTS OF THIS DRAWING ARE THE EXCLUSIVE PROPERTY OF THE TECHNICAL MATERIEL CORP. ITS UNAUTHORIZED USE OR REPRODUCTION IN WHOLE OR IN PART IS STRICTLY FORBIDDEN.

NOTES

LD-1432  
A