

REQ. PER UNIT	USED ON			LD-1390 ○
	MODEL	ASS'Y. NO.	DATE	
1	GPT-200K (AT-105)	A-2765	1-20-64	

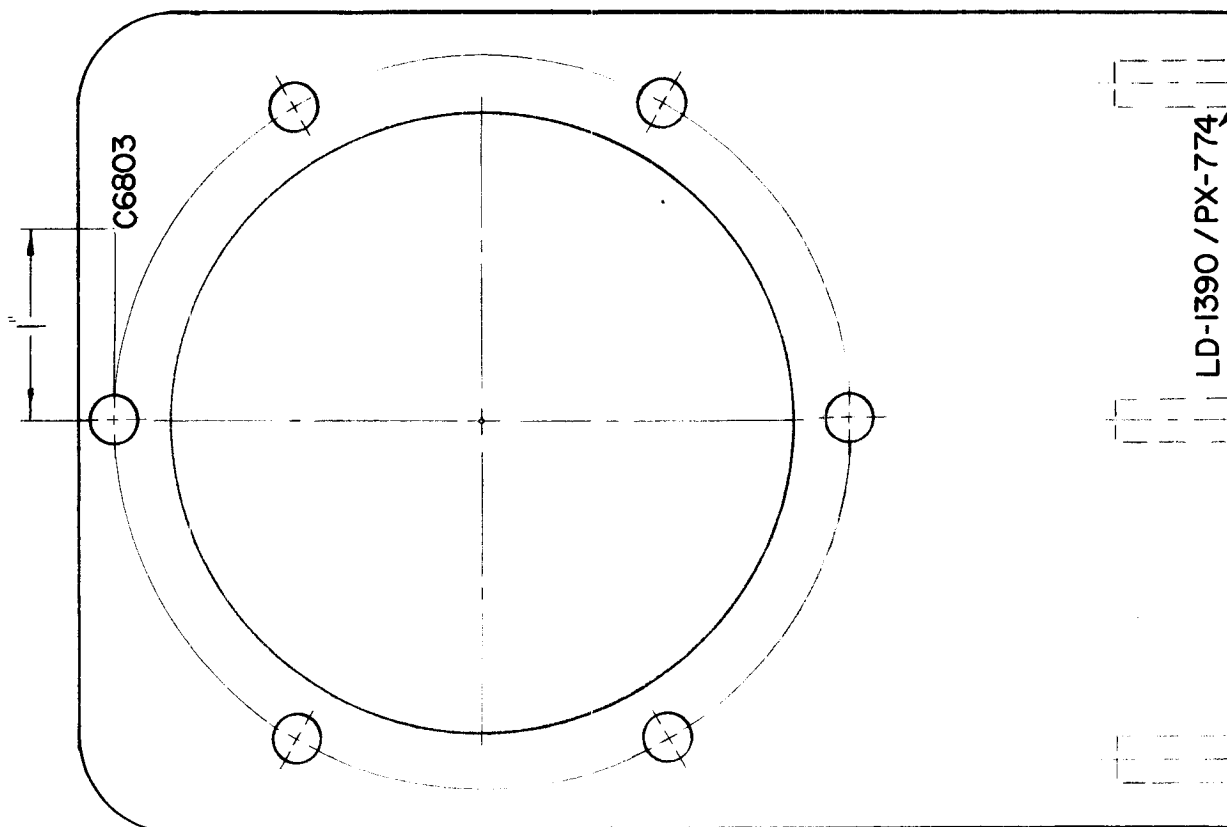

MARK TMC PART NO. WITH LATEST REVISIONS

MARKING PROCESS: AS PER TMC SPECIFICATION S-727.
LETTERING: 1/8 HIGH BLACK GOTHIC, LOCATED AS SHOWN.

REF: PX 774

							REQ. ITEM	PART NO.	F. BUDETTI	DESCRIPTION	SYMBOL
									THE TECHNICAL MATERIEL CORP. MAMARONECK, NEW YORK		
									MARKING PROCESS: AS PER TMC SPEC. S727		
									MARKING, SUPPORT, CAPACITOR		
○	ORIGINAL RELEASE FOR PRODUCTION	5-13-64	○	A.M.					SRG	aa	RC
SYM	DESCRIPTION	DATE	CH. NO.	DRAFTS	CHECKER	ENG. APP.	MATERIAL		DRAWN	CHECKED	FINAL APPROVAL
UNLESS OTHERWISE SPECIFIED DIMENSIONS ARE IN INCHES AND INCLUDE CHEMICALLY APPLIED OR PLATED FINISHES		SCALE		1" = 1"			TYPE & TEMPER		HEAT TREAT. SPEC.		
DECIMALS	TOLERANCES	FRACTIONS	CODE				FINISH & SPEC. NO.		ELEC. DES. APP.	MECH. DES. APP.	LD-1390 ○
.X ± .05		± 1/64	A								
.XX ± .01		ANGLES									
.XXX ± .005		± 0° 30'									