

REVISIONS				
ZONE	SYM	DESCRIPTION	DATE	E.M.N. NO.

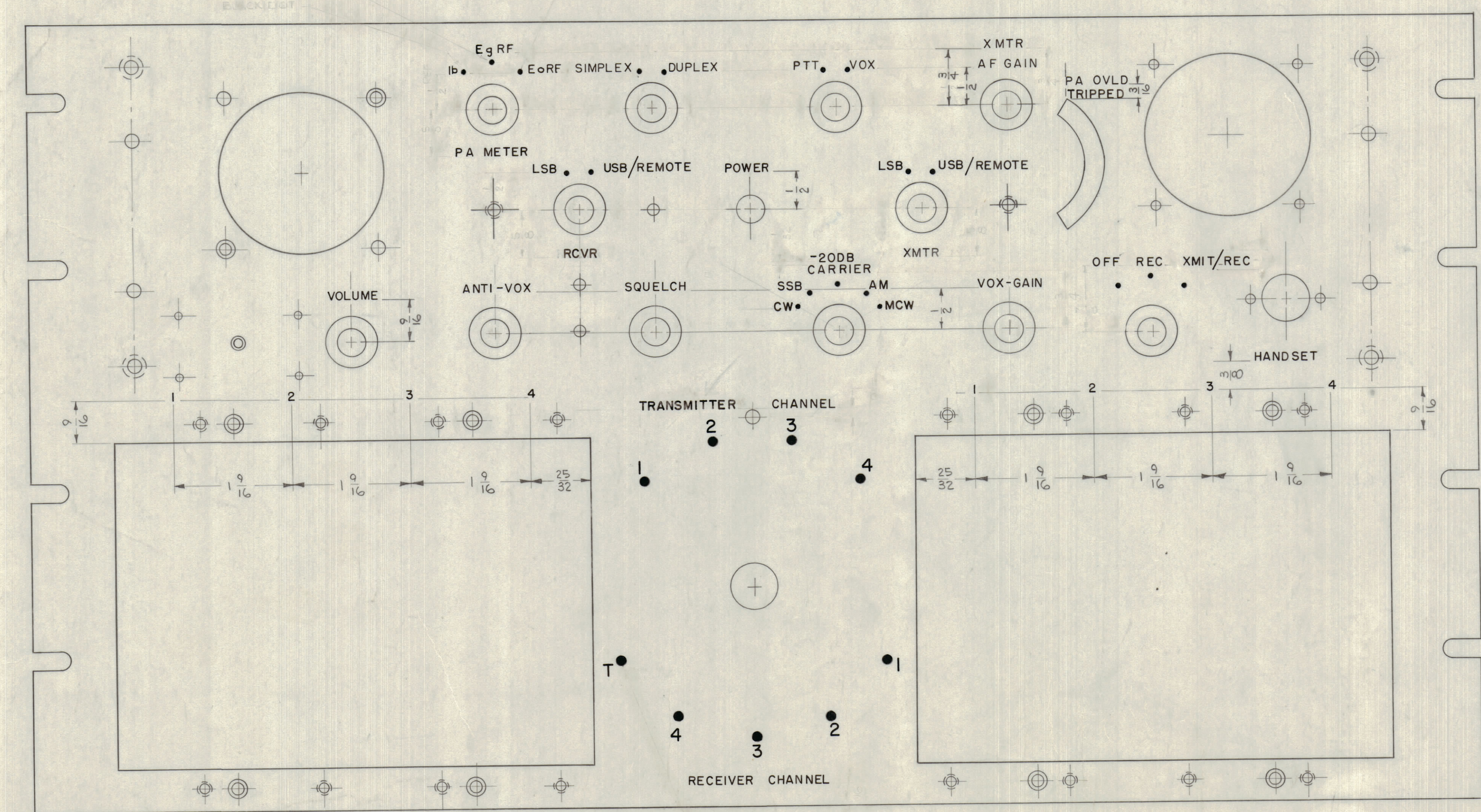
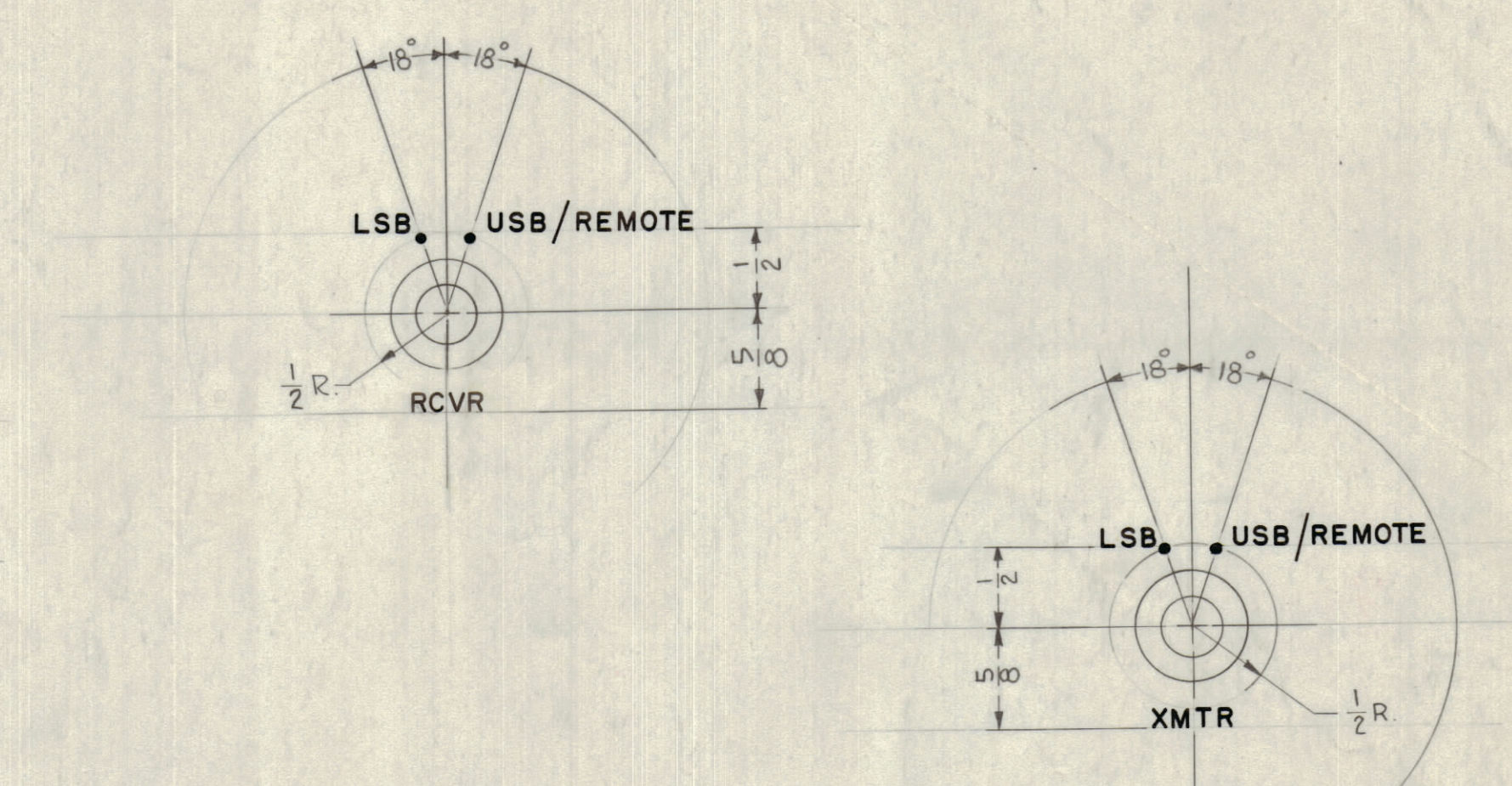
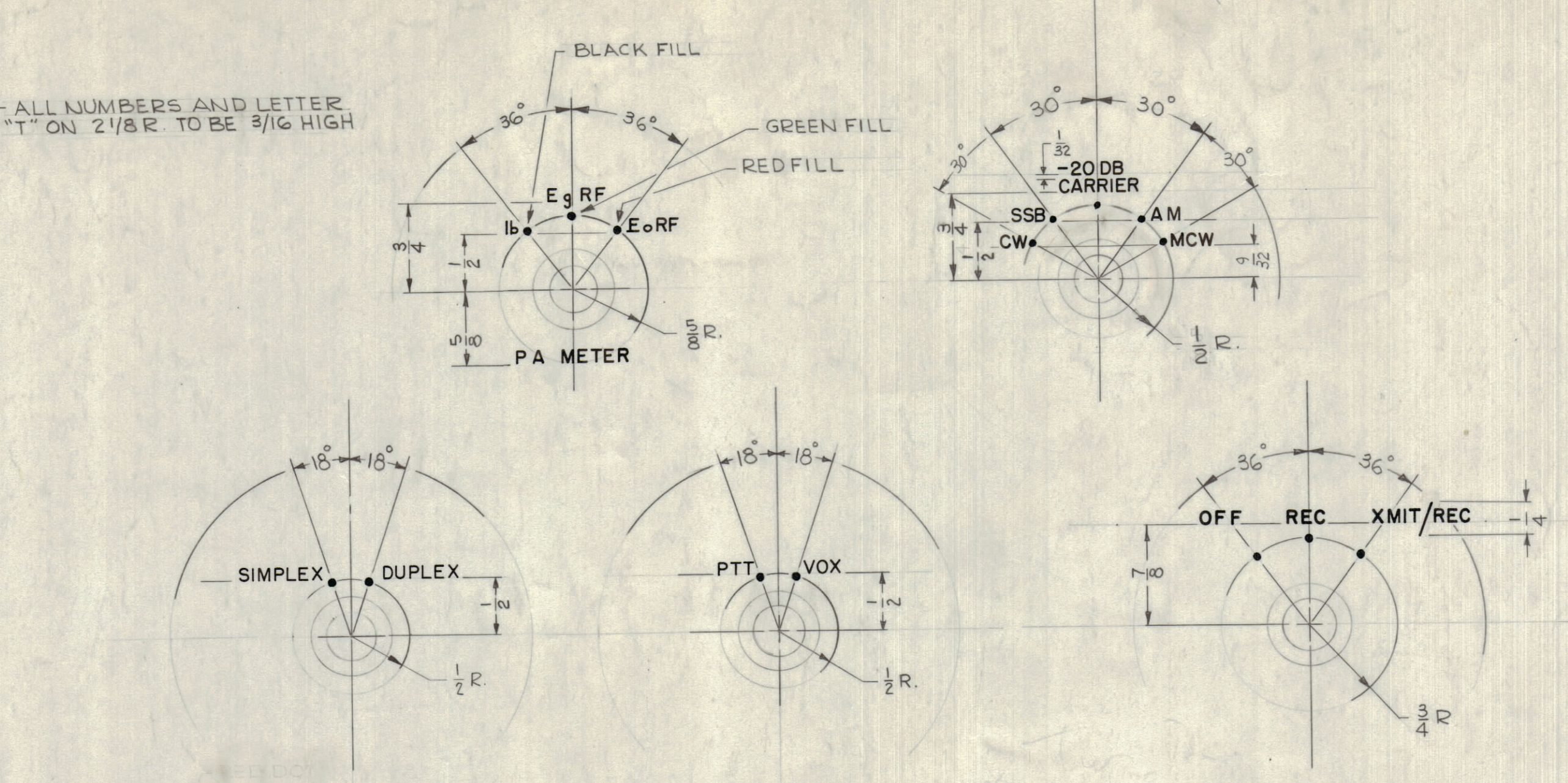
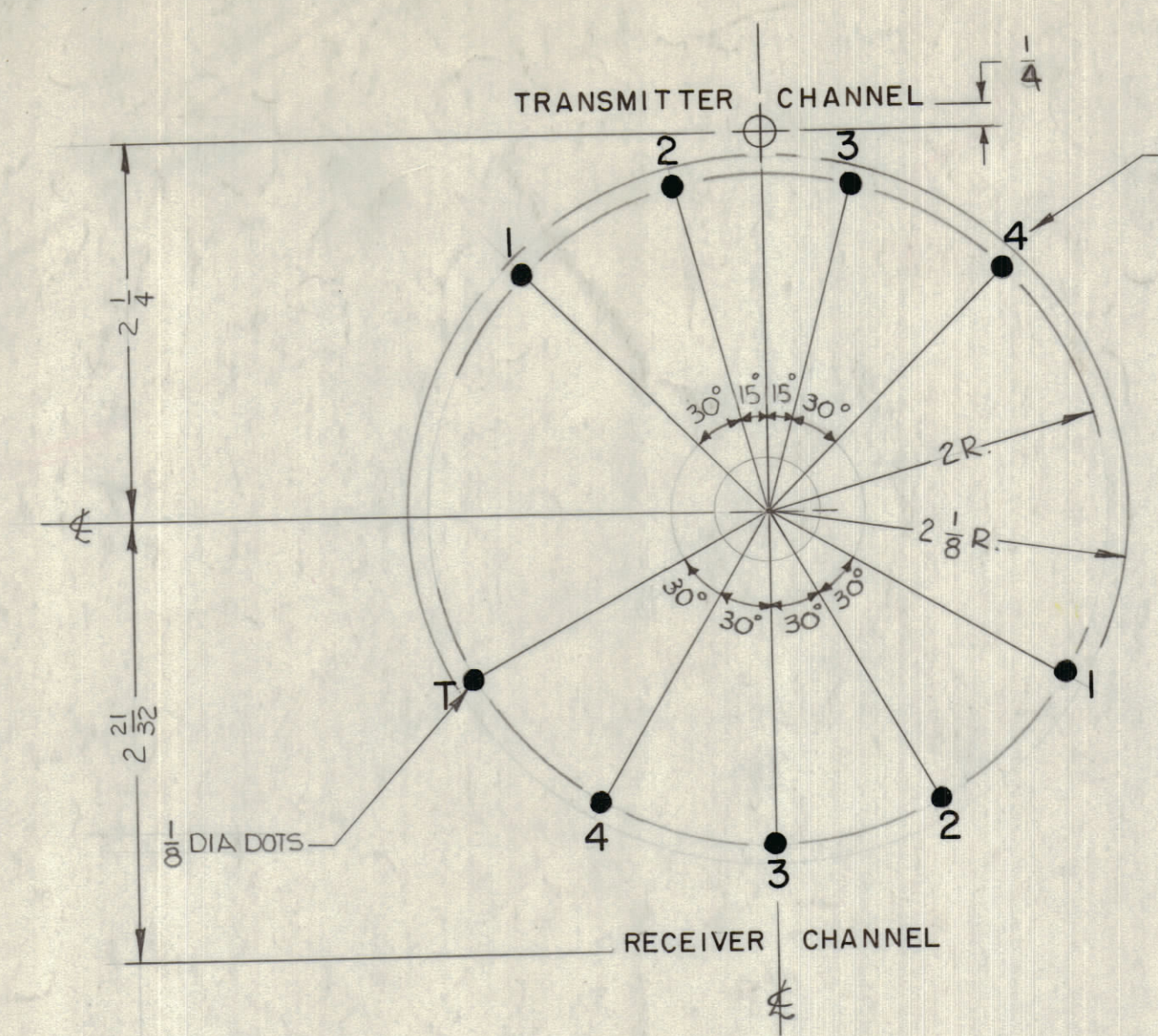

LETTER HEIGHT	DEPTH OF STROKE	WIDTH OF STROKE
1/8	.010	.020
3/16	.010	.020
1/16 D. DOTS	.010	-
1/8 D. DOTS	.010	-
SOLID LINE	.010	.015

NOTES:  
 1.- ALL DOTS TO BE 1/16 DIA., WHITE FILLED UNLESS OTHERWISE SPECIFIED.  
 2.- ALL LETTERING TO BE 1/8 HIGH GOTHIC, WHITE FILLED UNLESS OTHERWISE SPECIFIED.  
 3.- ALL LETTERING AND NUMERAL GROUP TO BE CENTERED ON HOLES

FRONT OF PANEL SHOWN

NOTES

1	TTR-10	AX-418
QTY./UNIT	MODEL USED ON	APP'Y. NO.
SCALE	1:1	A

REF: MS-3374

REQ'D.	ITEM	PART NUMBER	DESCRIPTION	SYMBOL

LIST OF MATERIAL	
MATERIAL	THE TECHNICAL MATERIEL CORP. MAMARONECK, NEW YORK
FINISH	TITLE MARKING, FRONT PANEL MARKING METHOD - ENGRAVING
UNLESS OTHERWISE SPECIFIED DIMENSIONS ARE IN INCHES AND INCLUDE CHEMICALLY APPLIED OR PLATED FINISHES	DRAWN: [Signature] DATE: 5/15/64
DECIMALS .X ± .05	CHECKED: [Signature] DATE: 5/15/64
FRACTIONS XX ± .01	ELECT. DES. R. KOHN DATE: 1-16-64
ANGLES XXX ± .005	MECH. DES. W. JORDAN DATE: 1/16/64
	LD-1322 SHEET 1 OF 2

LD-1322