

REVISIONS					
ZONE	SYM	DESCRIPTION	DATE	E.M.N. NO.	APPD
0		ORIGINAL RELEASE FOR PRODUCTION	3-3-64		A.M.

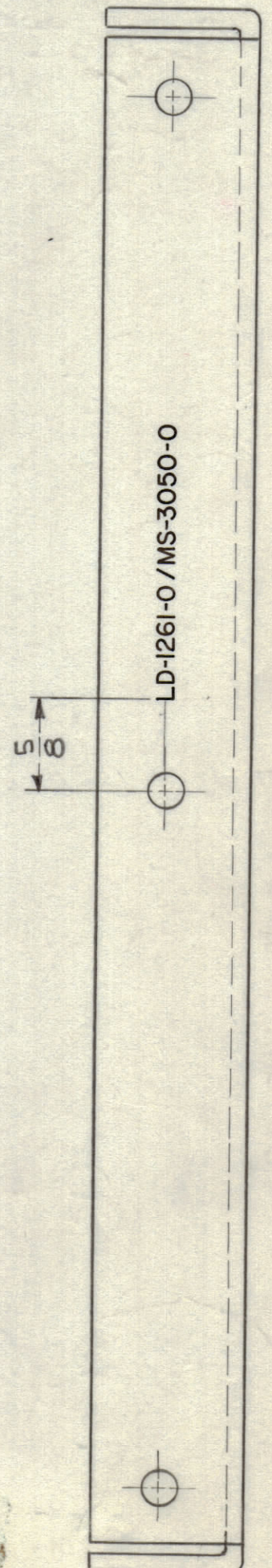
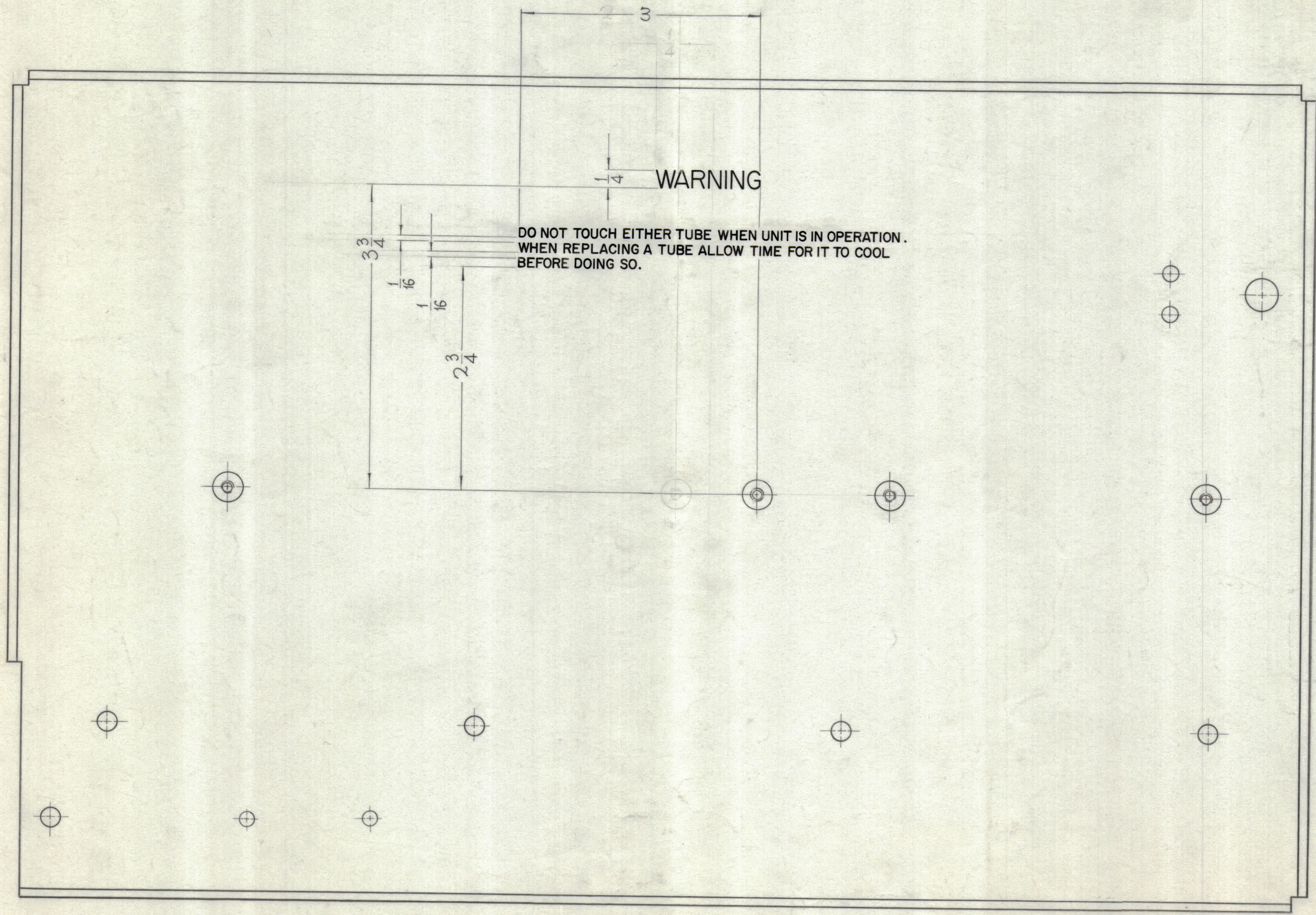

LD-1261-O

REF-TMC DWG. MS-3050

UNLESS OTHERWISE SPECIFIED
 MARKING PROCESS-AS PER TMC SPECIFICATION S-727.
 LETTERING- 1/8 HIGH GOTHIC, RED, LOCATED AS SHOWN.

NOTES

1	GPT-200K	AP-108
Q'TY./UNIT	MODEL USED ON	ASS'Y. NO.
SCALE 1:1	CODE A	

THE CONTENTS OF THIS DRAWING ARE THE EXCLUSIVE PROPERTY OF THE TECHNICAL MATERIEL CORP. ITS UNAUTHORIZED USE OR REPRODUCTION IN WHOLE OR IN PART IS STRICTLY FORBIDDEN.

REQ'D.	ITEM	PART NUMBER	DESCRIPTION	SYMBOL
F. BUDETTI LIST OF MATERIAL				
MATERIAL			THE TECHNICAL MATERIEL CORP. MAMARONECK, NEW YORK	
FINISH			TITLE MARKING, PLATE, SIDE RIGHT MARKING PROCESS: PER S-727	
UNLESS OTHERWISE SPECIFIED DIMENSIONS ARE IN INCHES AND INCLUDE CHEMICALLY APPLIED OR PLATED FINISHES		DRAWN John C. Biale	DATE 5/27/63	FINAL APPROVAL KJC
DECIMALS .X ± .05 .XX ± .01 .XXX ± .005		CHECKED JCS	DATE 3/12/64	DATE 3/12/64
TOLERANCES FRACTIONS ± 1/64 ANGLES ± 0° 30'		ELECT. DES. J.D.	DATE 2-11-64	DATE
MECH. DES.			DATE	DATE
SHEET			LD-1261	0
REV. LTR.				