

LD-1251

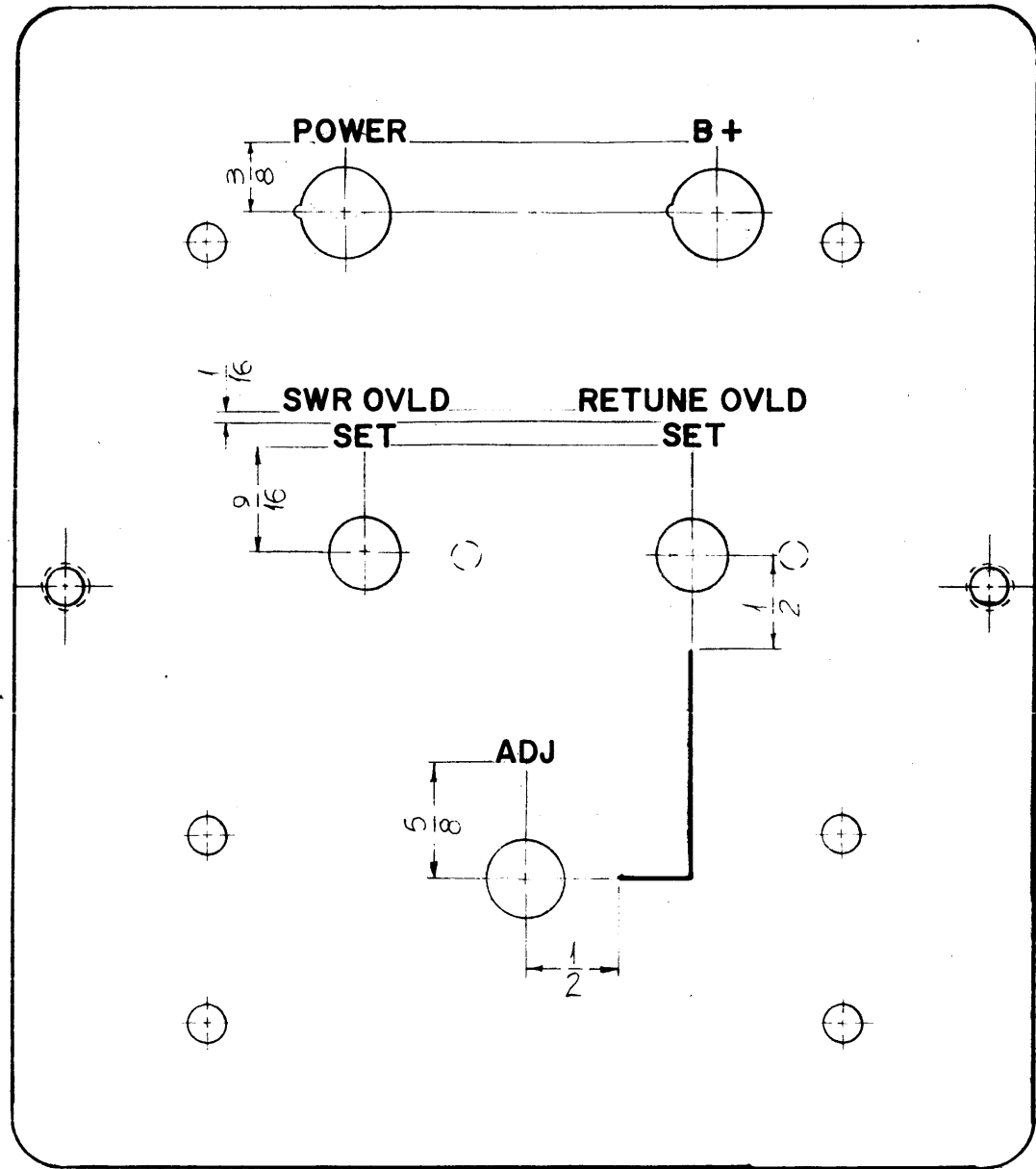

| REVISIONS |                                 |         |            |       |           |
|-----------|---------------------------------|---------|------------|-------|-----------|
| SYM       | DESCRIPTION                     | DATE    | E.M.N. NO. | DRAFT | CHKD APPD |
| 0         | ORIGINAL RELEASE FOR PRODUCTION | 2-28-64 |            | A.M.  |           |

**UNLESS OTHERWISE SPECIFIED:**

1-ENGRAVING: 1/8 HIGH GOTHIC, WHITE FILLED

2-ALL LINES LOCATE AS SHOWN.

| LETTERED HEIGHT | DEPTH OF STROKE | WIDTH OF STROKE |
|-----------------|-----------------|-----------------|
| 1/8             | .010            | .020            |
| SOLID LINES     | .010            | .015            |

REF- TMC DWG. MS-3266

| REQ'D.  | ITEM | PART NUMBER | DESCRIPTION   | SYMBOL          |
|---|------|-------------|---|-----------------|
| F BUDETTI LIST OF MATERIAL  |      |             |   |                 |
| MATERIAL  |      |             | <b>THE TECHNICAL MATERIEL CORP.</b><br>MAMARONECK, NEW YORK               |                 |
| FINISH  |      |             | TITLE<br>MARKING, FRONT PANEL (SWR RETUNE)<br>MARKING PROCESS - ENGRAVING |                 |
| UNLESS OTHERWISE SPECIFIED<br>DIMENSIONS ARE IN INCHES AND INCLUDE<br>CHEMICALLY APPLIED OR PLATED FINISHES |      |             | DRAWN<br>J.F. VITRO   | DATE<br>2/11/64 |
| DECIMALS<br>.X ± .05<br>.XX ± .01<br>.XXX ± .005  |      |             | CHECKED<br>J.C.B.   | DATE<br>2/11/64 |
| FRACTIONS<br>± 1/64<br>ANGLES<br>± 0° 30'   |      |             | MECH. DES.<br>S.D.  | DATE<br>2-11-64 |
|   |      |             | LD-1251   |                 |
|   |      |             | SHEET 1 OF 2  |                 |
|   |      |             | REV. LTR.   |                 |

|   |               |            |
|---|---------------|------------|
| 1   | GPT-200-K     | AZ-101     |
| Q'TY./UNIT  | MODEL USED ON | ASS'Y. NO. |
| SCALE<br>1:1  | CODE<br>A     |            |
| THE CONTENTS OF THIS DRAWING ARE THE EXCLUSIVE PROPERTY OF THE TECHNICAL MATERIEL CORP. ITS UNAUTHORIZED USE OR REPRODUCTION IN WHOLE OR IN PART IS STRICTLY FORBIDDEN. |               |            |

NOTES

LD-1251  
0

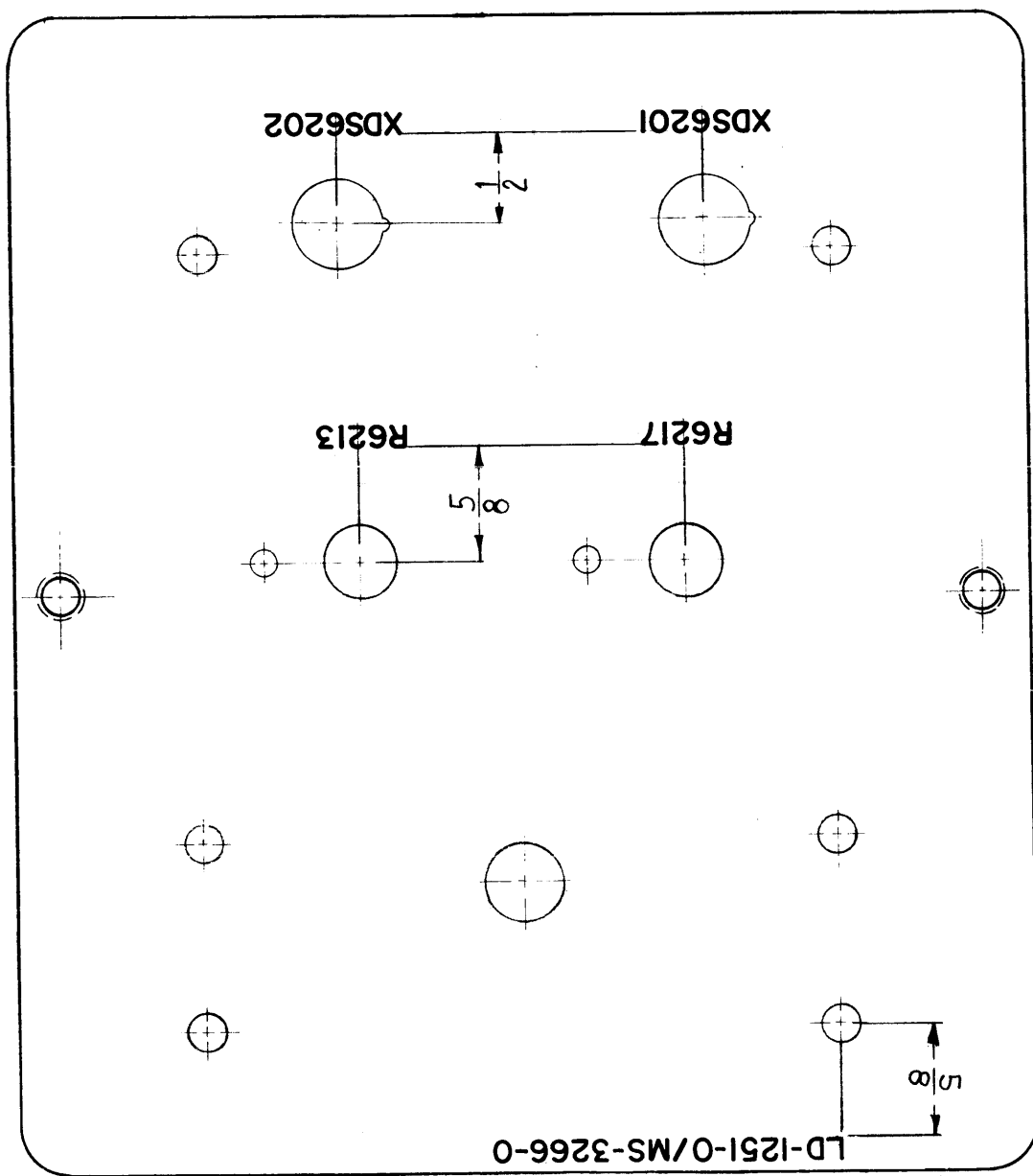

(REAR VIEW SHOWN)

|            |               |            |
|------------|---------------|------------|
| 1          | GPT-200K      | AZ-101     |
| Q'TY./UNIT | MODEL USED ON | ASS'Y. NO. |
| SCALE 1:1  | CODE A        |            |

THE CONTENTS OF THIS DRAWING ARE THE EXCLUSIVE PROPERTY OF THE TECHNICAL MATERIEL CORP. ITS UNAUTHORIZED USE OR REPRODUCTION IN WHOLE OR IN PART IS STRICTLY FORBIDDEN.

NOTES

REVISIONS

| SYM | DESCRIPTION                     | DATE    | E.M.N. NO. | DRAFT | CHKD | APPD |
|-----|---------------------------------|---------|------------|-------|------|------|
| 0   | ORIGINAL RELEASE FOR PRODUCTION | 2/28/64 |            | A.M.  |      |      |

UNLESS OTHERWISE SPECIFIED:  
 MARKING PROCESS: AS PER TMC SPECIFICATION S-727.  
 LETTERING: 1/8 HIGH BLACK GOTHIC, LOCATED AS SHOWN.

| REQ'D.  | ITEM | PART NUMBER | DESCRIPTION   | SYMBOL       |
|---|------|-------------|---|--------------|
| F. BUDETTI LIST OF MATERIAL   |      |             |   |              |
| MATERIAL  |      |             | THE TECHNICAL MATERIEL CORP.<br>MAMARONECK, NEW YORK                          |              |
| FINISH  |      |             | TITLE<br>MARKING, FRONT PANEL-REAR (SWR RETUNE)<br>MARKING PROCESS: PER S-727 |              |
| UNLESS OTHERWISE SPECIFIED<br>DIMENSIONS ARE IN INCHES AND INCLUDE<br>CHEMICALLY APPLIED OR PLATED FINISHES |      |             | DRAWN J.F.V.  | DATE 2/11/64 |
| DECIMALS .X ± .05<br>.XX ± .01<br>.XXX ± .005   |      |             | CHECKED S.D.  | DATE 2/11/64 |
| FRACTIONS ± 1/64<br>ANGLES ± 0° 30'   |      |             | MECH. DES. S.D.   | DATE 2-11-64 |
|   |      |             | FINAL APPROVAL RDC  | DATE         |
|   |      |             | LD-1251   | 0            |
|   |      |             | HEET 2 OF 2   | REV. LTR.    |