

ZONE		SYM		DESCRIPTION		DATE		E.M.N. NO.		DRAFT		CHKD		APPD	
X		1		ADJUSTING MULTIMETER BIAS ADJ A&B, PLATE MA, REVISED ORIGINAL RELEASE FOR PRODUCTION		11-12-57		X 1		JLB		JLL		J.D.	

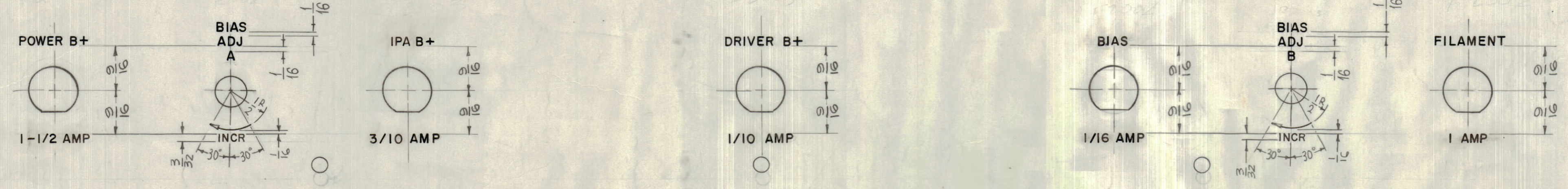

FRONT VIEW SHOWN

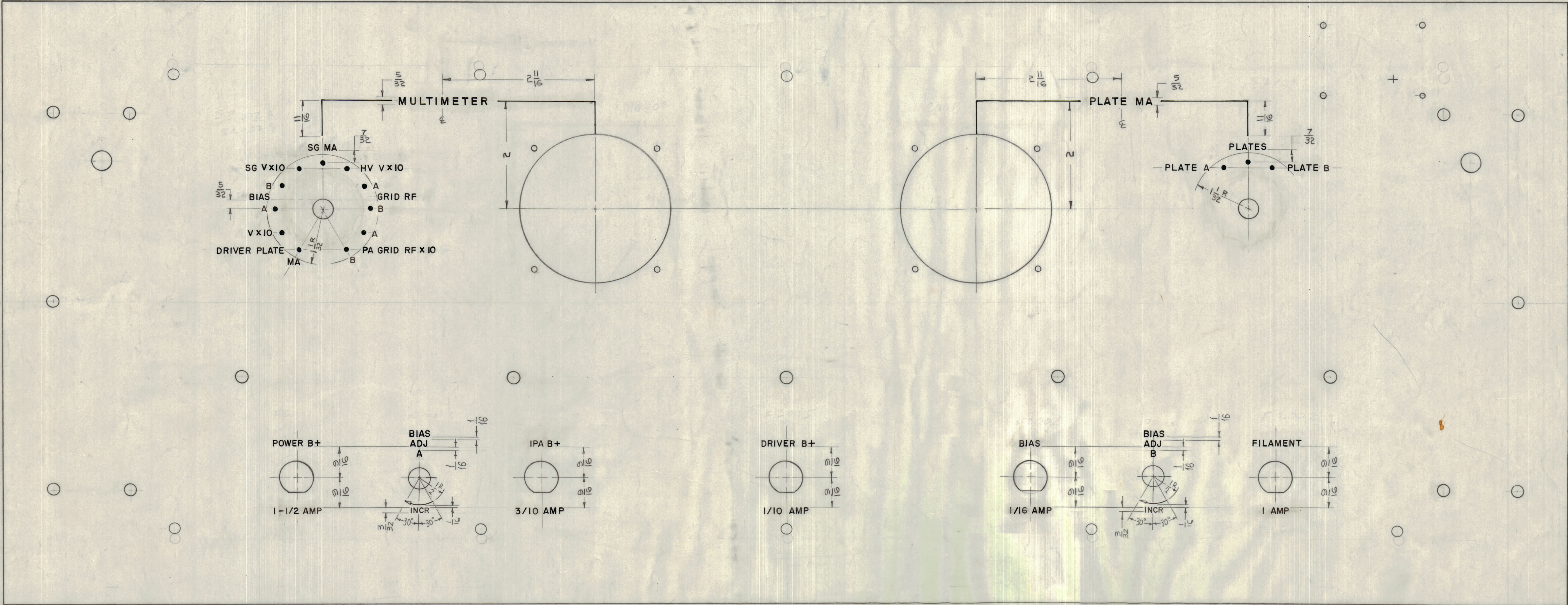
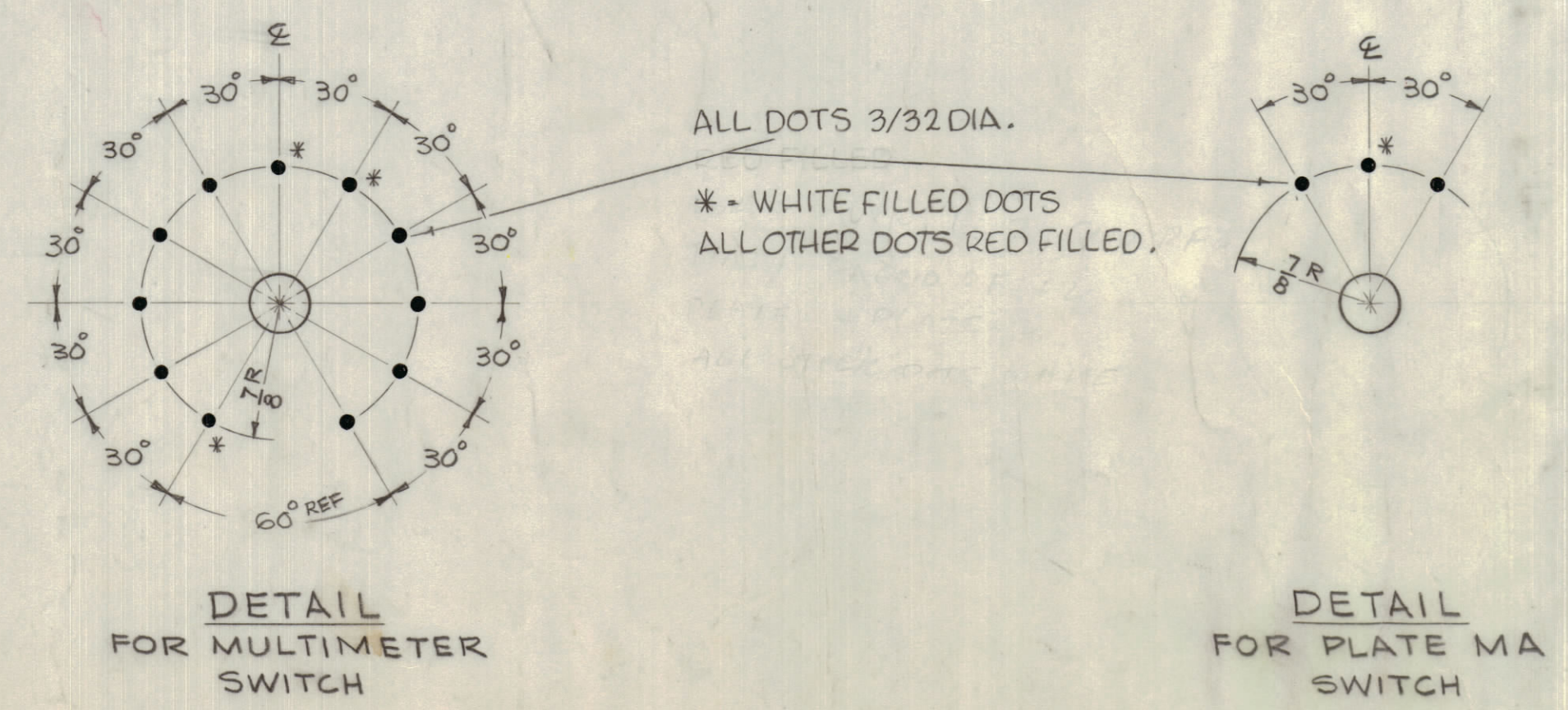

ALL DOTS 3/32 DIA.
 * - WHITE FILLED DOTS
 ALL OTHER DOTS RED FILLED.

- UNLESS OTHERWISE SPECIFIED: 2 NUMBERS TO BE RED FILLED.
- 1- ALL ENGRAVING AS PER TMC SPEC 5586.
 - 2- ENGRAVING TO BE GOTHIC WHITE FILLED. SIZES SHOWN ON CHART.
 - 3- ALL LINES WHITE FILLED.
 - 4- ALL NUMBERS, LETTERS & ARROW HEADS: WHITE FILLED; X: WHITE FILLED; * WHITE FILLED.
 - 5- ALL DOTS RED OR WHITE FILLED.
 - 6- ALL LETTER GROUPS TO BE CENTERED ON HOLES OR DOTS, AS SHOWN.
 - 7- ALL ARROWHEADS WHITE OUTLINE FILL.

HEIGHT OF LETTERS	DEPTH OF STROKE	WIDTH OF STROKE
1/8 & 3/32	.010	.020
DOTS	.010	1/16 DIA
LINES	.010	.015
ARROW HEADS	.010	SEE DETAIL

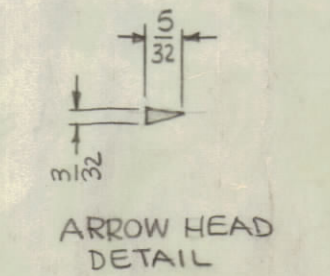

NOTES

1	GPT-10K LF AX-	ABS. NO.
QTY/UNIT	MODEL USED ON	CODE
SCALE	1/1	

REF: M53134

REQ'D	ITEM	PART NUMBER	DESCRIPTION	SYMBOL
MATERIAL				
POSE				
LIST OF MATERIAL				
THE TECHNICAL MATERIAL CORP. MAMARONECK, NEW YORK				
TITLE				
ENGRAVING, FRONT PANEL				
UNLESS OTHERWISE SPECIFIED DIMENSIONS ARE IN INCHES AND INCLUDE CHEMICALLY APPLIED OR PLATED FINISHES		DRAWN	DATE	FINAL APPROVAL
DECIMALS ± .005		JLB	3-12-53	J.D.
FRACTIONS ± 1/64		CHECKED	DATE	
ANGLES ± 0° 30'		JLB	6-29-45	
TOLERANCES		ELECT. DES.	DATE	
		JLB		
		MECH. DES.	DATE	
		JLB		
SHEET 1 OF 2				REV. LTR.

LD1198